



Universal Intraoral Video Camera System

Part Number D7500

Operator's Manual



**AIR
TECHNIQUES**
INC.

ISO
9001
ISO 13485
FDA-GMP COMPLIANT

FOREWORD

Air Techniques has prepared this document as a guide to the proper use of the Polaris Universal Intraoral Video Camera System. Review and follow the guidelines included in this Operator's Manual to ensure that your Polaris System gives you the highest level of service.

For product support and information on how to expand your Polaris System, contact your authorized Air Techniques dealer; call our Technical Support at 1-800-AIR-TECH (1-800-247-8324) or visit the Air Techniques web site:

www.airtechniques.com

TABLE OF CONTENTS

	<u>Page</u>
General Safety	3
Congratulations	4
Important Information	5
Box Contents	6
Key Parts Identification	7
Component Description	7
Pre-Installation Information	9
Handpiece Functions	10
Control Module Functions	11
System Interconnections	12
Installation	12
Camera Portability	16
Pre-Operation	17
Activation	18
System Operation	18
Diagnostic Procedures	20
Maintenance	21
Specifications	22
Physical Characteristics	22
Accessories	23
VISIX Imaging Software	24
Warranty	25
On-Line Warranty Registration	25

This equipment has been designed to minimize exposure of personnel to hazards. While the Polaris System is designed for safe operation, certain precautions must be observed. Use of the Polaris System not in conformance with the instructions specified in this manual may result in permanent failure of the unit.

KNOWLEDGE OF WARNINGS AND CAUTIONS

Users must exercise every precaution to ensure personnel safety, and be familiar with the warnings and cautions presented throughout this manual and summarized below.

Warnings.

- To prevent fire or electrical shock, do not expose this equipment to rain or moisture.
- Do not spray cleaning liquids or disinfectants directly on the camera handpiece or the Handpiece Cable. Use care not to allow liquids to run into internal circuitry.
- Do not wipe the surfaces using benzine, thinner, etc. as this may degrade the finish.

Cautions.

- There are no user-serviceable parts inside. Servicing should be performed by qualified dealer service representatives only.
- Connecting any device to the Polaris System that does not meet the equivalent safety requirements of the system may reduce the safety effectiveness of the Polaris System.
- Unplug the system components from power before performing cleaning procedures.

Contraindications.

- None known.

Use of Accessory Equipment.

All peripheral equipment (computers, monitors, printers, etc) connected to this equipment must comply with IEC 60601-1 and the resulting system must comply with IEC 60601-1 and/or IEC 60601-1-1 harmonized national standards when set-up within the immediate patient vicinity (ie. within 6 feet).

Accessory equipment outside the patient vicinity must comply with IEC 60601-1 or IEC 60950-1 as allowed by IEC 60601-1-1.

Use of ACCESSORIES or cables other than those specified or provided by Air Techniques may result in increased EMISSIONS or decreased IMMUNITY of the equipment.

Do Not Attempt Internal Service.

The interior of the camera is only accessible by removing hardware with tools and should only be opened and serviced by an authorized service technician.

Contact your local Air Techniques authorized dealer for service. Failure to heed this directive may result in equipment damage and voiding the warranty.

GENERAL SAFETY

Markings.

The following terms or symbols are used on the equipment or in this manual to denote information of special importance:



Alerts users to important Operating and Maintenance instructions. Read included documents.



Indicates type BF equipment in accordance with UL/IEC 60601-1



Alerts users that the camera cover must be used for only one patient and disposed of properly in accordance with local code.



Identifies the name of the manufacturer.



Indicates date of manufacture.

ATTENTION USERS:

Manufacturing date code on serial number label is in the format: MONTH YYYY.

Manufacturer: Air Techniques, Inc.
1295 Walt Whitman Road, Melville, New York 11747 USA

CONGRATULATIONS

Congratulations on your purchase of the Polaris Universal Intraoral Video Camera System, the latest camera in the dental video imaging product line from Air Techniques, a leading manufacturer of dental equipment since 1962. The Polaris Universal Intraoral Video Camera System is hereafter referred to as the Polaris System in this manual.

The Polaris System design offers the benefits of a flexible and reliable image capturing system that is easily integrated into any practice. The very lightweight one-piece Polaris Camera Handpiece is an extremely maneuverable instrument, which produces crisp, clear images.

In addition to providing quality high-resolution images, the Polaris Camera Handpiece is a versatile addition that can grow with your practice. Using a quick-disconnect feature the Polaris Camera Handpiece quickly detaches and is easily carried among patient operatories for use with other Polaris System components.

This manual covers the installation, operation and maintenance of:

- Polaris Camera Handpiece with Control Module, Power Supply Adapter and CablesD7500
- Polaris Camera HandpieceD7520
- Control Module with Power Supply Adapter and Cables. . . .D7560

Review and follow the guidelines included in this Operator's Manual to ensure that your Polaris System gives you the highest level of service. For product support and information on how to expand your Polaris System, contact your authorized Air Techniques dealer.

General Notes.

- All instructions in this manual form an integral part of the unit. They must be kept close to the unit and in readiness whenever required. Precise observance of these instructions is a pre-condition for use of the unit for the intended purpose and for its correct operation. This manual should be passed on to any future purchaser or operator.
- Safety of the operator as well as trouble-free operation of the unit are only ensured if use is made of original equipment parts. Moreover, use may only be made of those accessories that are specified in the technical documentation or that have been expressly approved and released by the manufacturer for the intended purpose. The manufacturer cannot warranty for the safety or proper functioning of this unit in the case where parts or accessories are used that are not supplied by the manufacturer.
- There is no guarantee against damage arising where parts or accessories are used that are not supplied by the manufacturer.
- Observe the usage and storage conditions.
- The Polaris System may only be operated using authorized software.
- The manufacturer regard themselves as being responsible for the equipment with regard to safety, reliability and proper functioning only if assembly, resetting, changes or modifications and repairs have been carried out by an authorized dealer and if the equipment is used in conformity with the instructions contained in this manual.
- The device conforms to the relevant safety standards valid at this time.
- Any reprinting of the technical documentation, in whole or in part, is subject to prior written approval by the manufacturer.

Incorrect Usage

- Any use that is not described in this manual as correct usage is considered as incorrect usage. The manufacturer is not to be held liable for any damage caused as a result of incorrect usage. The operator bears all risks.

UNPACKING AND INSPECTION

Unpack each component of the Polaris System and inspect for physical damage such as scratched panels, damaged connectors, etc. If any damage is noted, immediately notify your Air Techniques authorized dealer immediately so corrective action can be taken.

Make sure to save all packaging material in case repackaging and shipment is necessary. Verify that all listed items were received. If any item is missing, notify your Air Techniques authorized dealer.

BOX CONTENTS

The Polaris System is comprised of a Camera Handpiece and Control Module. Each is boxed separately along with associated accessories and is available individually by their selling numbers D7520 and D7560 respectively. When shipped together as a complete Polaris System, the separate boxes are packed in a single box as selling number D7500. Some of the items may be purchased individually by the part numbers listed below or as listed on page 23.

The following lists the components included with the Polaris System.

Polaris System, Part Number D7500, includes:

Item	Quantity
Contents of D7520 Camera Handpiece Box	
Camera Handpiece	1
Disposable Camera Covers Sample Pack	20
Camera Handpiece Instructions	1
Contents of D7560 Control Module Box	
Camera Control Module	1
Dual Lock Fastener Kit	1
Handpiece Cable, 15 feet	1
Power Supply Adapter	1
RCA Male Composite Cable	1
Handpiece Holder with Chair-side Adapter	1
USB 2.0 High Speed Cable	1
CD containing - PDF version of Operator's Manual USB Device Drivers Demonstration Program and Utilities Adobe Acrobat Reader	1
Quick Start Instructions	1

KEY PARTS IDENTIFICATION

Supplied Polaris System Components

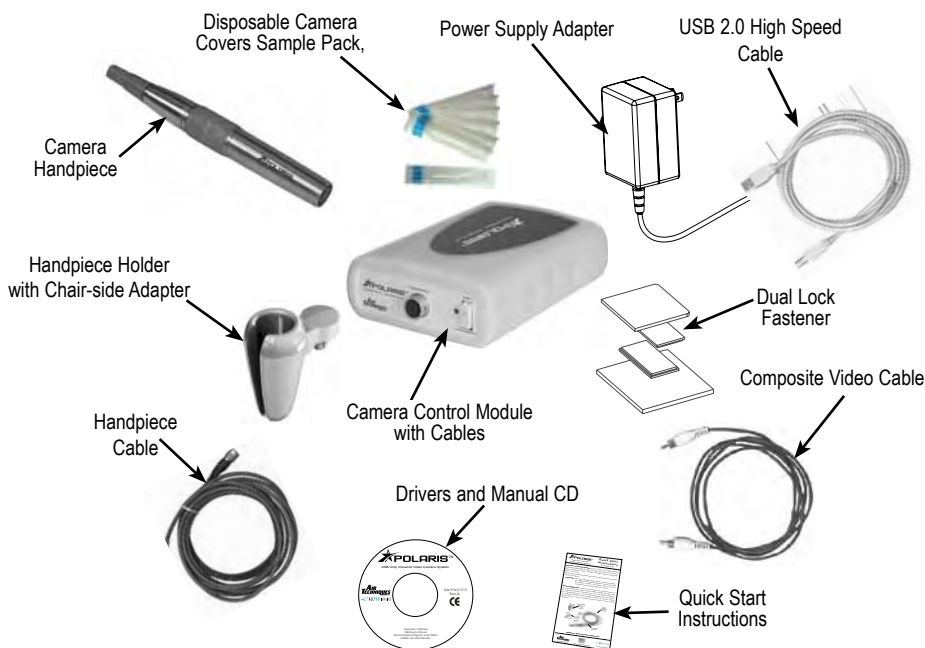

COMPONENT DESCRIPTION

The Polaris System is an intraoral camera system designed for dental applications that consists of the Camera Handpiece with holder, Control Module, Power Supply Adapter and associated cables as described below.

NOTE: Air Techniques' VISIX Imaging Software is fully compatible with the Polaris System. Contact your authorized Air Techniques dealer to acquire VISIX.

Camera Handpiece - The Camera Handpiece is extremely lightweight with a high resolution, high sensitivity, auto-exposure controlled CCD sensor and a high performance lens system illuminated by ultra-bright white LED lamps. The fixed focus lens has a broad depth of field enabling the camera to finely detail a section of a single tooth to a tour of the mouth. The Camera Handpiece has the rich look and tactile feel of a metallic handpiece and provides 2 keypad buttons for fingertip operating control of the system. The specific functions performed by the keypad buttons depend on the user-supplied compatible streaming video capture software application used.

COMPONENT DESCRIPTION

Camera Covers Sample Pack - Provides a sample quantity of 20 disposable camera covers used as an effective barrier preventing any infection hazard to the patient.

Polaris Handpiece Holder - The Polaris Handpiece Holder can be fastened in a convenient location for safe storage of the handpiece when it is not in use. In addition to storage, the handpiece holder also has built-in magnets that turn off the Polaris Handpiece power. This feature conserves energy and equipment wear, allowing the system to be ready and operational when needed.

Control Module - The Control Module is the single-point interconnection interface between the Camera Handpiece and a computer and/or video monitor as required. This Control Module is designed to connect to a PC with USB streaming video capture software or to a PC with an installed capture card and associated video capture software. When connected to a PC, the live video images taken by the Camera Handpiece are displayed on the computer monitor and can be saved on the computer's hard disk via the video capture software application. When operated directly connected to only a video monitor, the connected monitor displays high-resolution live video images taken by the Camera Handpiece.

Power Supply Adapter - The 15-watt power supply adapter connects to the Control Module to provide 12 VDC power for operating the Polaris System.

Camera Handpiece Cable - This 15-foot multi-conductor cable with quick-disconnect connectors at each end interconnects between the Camera Handpiece and the Control Module providing all power, video output and control for camera operation. Optional 6, 9, 30 and 50-foot length cables are available from your Air Techniques Dealer.

USB 2.0 High Speed Cable - A 6-foot USB 2.0 cable that connects between the Control Module and the high power (500 mA) USB 2.0 port of the user's computer. Provides a digital video and camera button control output for use with a PC with user-supplied compatible streaming video capture software application.

Composite Video Cable - A 6-foot composite video cable is used to connect between the Control Module and external video monitor or computer with video capture card for direct viewing.

Compact Disk - A compact disk (CD) included with the Polaris System that includes:

1. USB Device Drivers Demonstration Program and Utilities
2. PDF version of Operator's Manual
3. Adobe Acrobat Reader

PRE-INSTALLATION INFORMATION

IMPORTANT: When operating the Polaris System connected to the USB 2.0 port on a Computer System, the computer must also be loaded with Air Techniques Authorized Twain or DirectX 9 compliant streaming video software application such as VISIX. Contact your dealer for available Computer Systems and software options.

NOTE: VISIX Imaging Software is fully compatible with Polaris Systems.

Minimum Computer System Requirements - The Computer System (laptop or computer, monitor, etc.) and any related peripheral or other equipment, supplied by the user, or a third party, must comply with the requirements for accessory Equipment as specified in the appropriate IEC 60601-1 and/or IEC 60601-1-1 harmonized national standard. Unless otherwise stated, the components of the computer system must comply with the minimum requirements listed below.

CPU Speed:	Pentium-4, 2 GHz or higher
Operating System:	Windows XP Professional with Service Pack 3 or later for an Intel 32-bit processor; Microsoft Windows XP Professional 64-bit Edition with Service Pack 2 or later for an Intel 64-bit extended (x64) processor; Microsoft Windows Vista Business, Enterprise, or Ultimate with Service Pack 1 or later for an Intel 32-bit or an Intel 64-bit extended (x64) processor; Microsoft Windows 7 Professional, Enterprise, or Ultimate for an Intel 32-bit or an Intel 64-bit extended (x64) processor.
System RAM:	256 MB
Optical Drive:	CD-ROM Capable
Monitor :	800 x 600 resolution or higher
Video Display Adapter:	16 MB video card with 800 x 600 pixel resolution and 32-bit color
USB Port:	USB 2.0 High-Speed Port

System Properties.

If unsure of the operating system version installed, check that it meets the necessary requirements by checking the **System Properties** window.

This is done simply by right clicking the My Computer icon. Selecting Properties from the menu list displays the **System Properties** window as shown. The installed operating system version is listed under the **General Tab**.

The **System Properties** window can also be displayed from the Desktop Start button. Just press the Start button and select **Settings**→**Control** Panel and then System.



Polaris Camera Handpiece

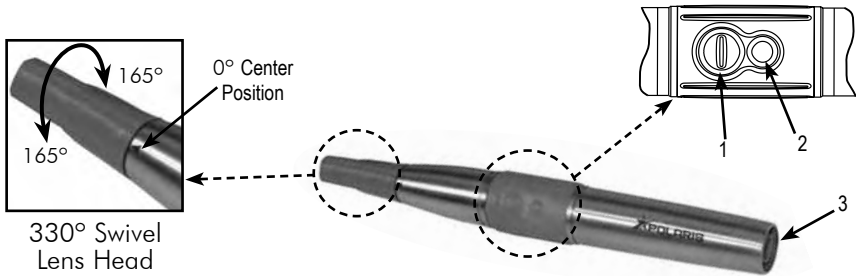

IMPORTANT: Use care when adjusting the Handpiece lens head. The swivel lens head turns only 165° left or right from the center point. Forcing the head past the 165° limit will damage the device.

Prior to rotating the lens, slide the Camera Cover about 1/2 to 3/4 inches up on the handle to provide enough slack in the cover for unrestricted rotation.

330° Swivel Lens Head Adjustment - The 330° swivel lens head design allows the lens orientation to be adjusted nominally 165° left or right from the center point to easily view and capture all desired angles during an examination.

Keypad Buttons - Each keypad button provides the Polaris Camera Handpiece fingertip control over the PC streaming video capture software via the Handpiece Cable. The specific functions performed by the keypad buttons depend on a software installation that supports the 2-button handpiece. Typical keypad actions provided below.

NOTE: Simultaneously depressing both keypad buttons for approximately 3 seconds deactivates the Camera Handpiece LED light source. This is commonly used when imaging an X-ray on a light box.

- | | |
|--------------------------|--|
| (1) Top Keypad Button | Press and release to send a <i>Button 1</i> command to the PC. While the specific function performed depends on the setting of the video capture software application installed on the PC, this command typically freezes and unfreezes the image that is displayed on the computer monitor. |
| (2) Bottom Keypad Button | Press and release to send a <i>Button 2</i> command to the PC. While the specific action depends on the video capture software installed, it typically saves the image displayed on the computer monitor to the computer hard disk. |
| (3) Handpiece Connector | A 8-pin connector socket that accepts connection of the keyed 8-pin quick disconnect plug end of the Handpiece Cable. |

Control Module Front Panel Controls and Indicators



CAMERA Connector

A 10 pin connector socket that accepts connection of the keyed 10-pin quick disconnect plug end from the multi-conductor Handpiece cable. Makes connection between the Camera Handpiece and Control Module to provide power, video output and control for the camera.

Power Indicator Lamp

A green LED lamp that illuminates to indicate the presence of 12 VDC operating power from the power supply adapter.

STANDBY/ON Switch

A rocker panel switch that controls the application of 12 VDC operating power from the Power Supply Adapter.

When set in the ON position, the 12 VDC is applied, the LED power indicator lamp illuminates, and the camera is operational.

The 12 VDC is removed and the camera is turned off when the switch is set in the STANDBY position and the LED power indicator lamp extinguishes.

Control Module Rear Panel Connectors



12 VDC Connector

Provides connection of the 12 VDC operating power from the Power Supply Adapter.

S-VIDEO Connector

A 4-pin Mini DIN connector that provides output connection for S-Video peripherals (e.g. video monitor or computer with capture card).

VIDEO Connector

An RCA connector that provides connection for composite video peripherals (e.g. video monitor or computer with capture card).

USB Connector

A USB type B connector that provides connection to the USB 2.0 High Speed port of the computer.

SYSTEM INTERCONNECTIONS

Polaris System - The diagram below shows the possible interconnections for the Polaris System. The heavy solid connection lines designate the typical operating configuration (connected to a computer system). The dashed line shows the optional connection to a video monitor, while the lighter solid connection lines show camera and power connections common to all system setups. Connect the Polaris System as required by individual office equipment.

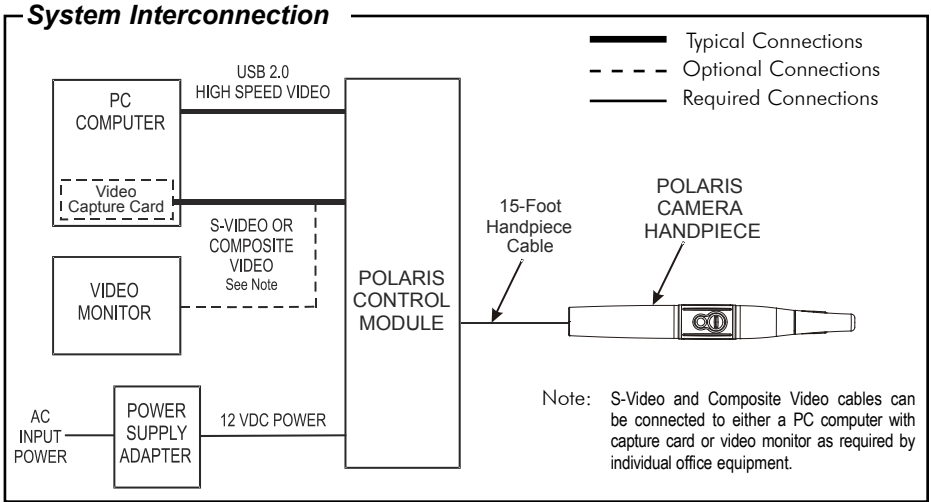

INSTALLATION

Installing the Polaris System is as simple as deciding where to place the Control Module and making the necessary cable connections to a video monitor and/or a PC loaded with an Air Techniques Authorized DirectX 9 compliant user-supplied streaming video software application such as Visix. Perform the following procedures to install the Polaris System.

Control Module Location - Locate the Polaris Control Module on a table top, cart or any flat stable surface convenient to an AC wall outlet and associated computer system/monitor. It can also be installed hanging under a table top, under the chair or on the computer using the supplied Dual Lock Fastener Kit. Make sure that the selected location allows easy access to front and rear panel controls and connectors.



NOTE:

Do not twist or turn the cable connectors. The Handpiece Cable connectors are keyed and mate straight on with the associated Camera Handpiece and Control Module connectors.

In addition to the supplied 15-foot multi-conductor cable, optional 6, 9, 30 and 50-foot lengths are available from your authorized Air Techniques Dealer at an extra cost.

Camera Cable Connection - Carefully connect the supplied Camera Handpiece Cable between the Camera Handpiece and Control Module as follows:

Camera Handpiece Connection.

1. Using the gray molded connector cable end, align the connector key with the keyway of the Handpiece connector.
2. Insert straight into Handpiece connector until it securely snaps into place.

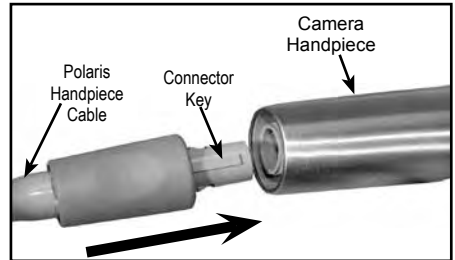

Control Module Connection

1. Using the 10-pin quick disconnect plug end, align connector key with the keyway of the mating CAMERA connector located on the front panel of the Control Module.
2. Insert the connector straight into the mating CAMERA connector until it securely snaps into place.

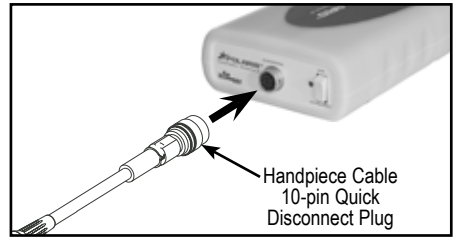

Polaris Handpiece Holder with Chair-side Adapter - Installing the Chair-side Adapter is as easy as deciding on a location for maximum convenience and securing it to an empty customer-supplied standard Handpiece Holder. Refer to the illustration below and install the Chair-side Adapter as follows:

1. Insert Handpiece Holder Adapter (1) into the wide end of Grip (2).
2. Press Grip (2) into the top of the chosen Handpiece Holder.
3. Insert Expander (3) into the bottom of Grip (2)
4. Insert and push the Joint Connector Hex Bolt (4) into Expander (3) engaging the thread of Handpiece Holder Adapter (1) by turning the Joint Connector Hex Bolt (4) clockwise.
5. Using the supplied Short Arm Allen Wrench (5), tighten Joint Connector Hex Bolt (4) until the Chair-side Adapter is secure in the Handpiece Holder.

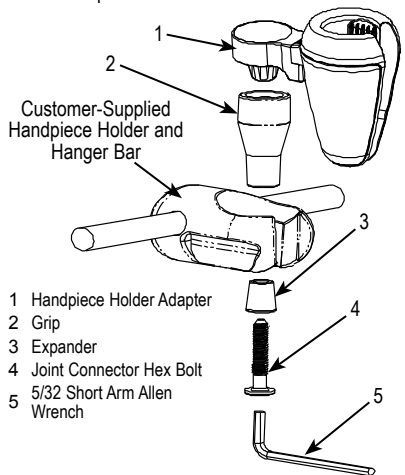

Handpiece Holder Chair-side Adapter Assembly

INSTALLATION

USB Digital Video/Button Control Connection Options - Refer to corresponding figure below and perform the following procedure to connect the USB 2.0 High Speed output of the Polaris Control Module to the associated PC computer as desired.

1. Connecting Directly to PC. Connect the supplied 6-foot USB 2.0 high-speed cable between the USB connector located on the rear of the Control Module to be connected and directly to the USB 2.0 high speed, high power (500 mA) port on the computer.
2. Connecting via High Speed Hub. Connect the supplied USB 2.0 high-speed cable between the USB connector located on the rear of the Control Module to be connected and the USB 2.0 High Speed Hub. If necessary, connect an additional USB 2.0 high-speed cable up to 16 feet long between the High Speed Hub and the USB 2.0 high speed, high power (500 mA) port on the computer.

USB Cable Connection Directly to PC

NOTES:

On PC's that have both front and rear USB 2.0 high speed ports, it is recommended that the camera be connected to one of the rear mounted ports for best results.

Minimum PC processor and operating system requirements are listed in the Preinstallation Information of this manual.

A DirectX 9 user-supplied compliant streaming video capture software application must be installed on the PC to display live video. The supplied CD provides the required WDM drivers.

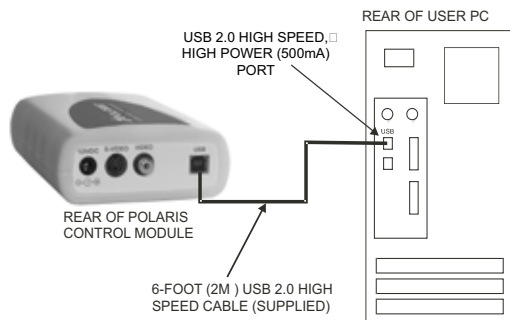

USB Cable Connection via Hub

NOTES:

A Hub may be used to connect the camera to the PC when the connection is longer than 6 feet or when the PC only has a single USB 2.0 high speed port and the camera must be connected along with other USB devices.

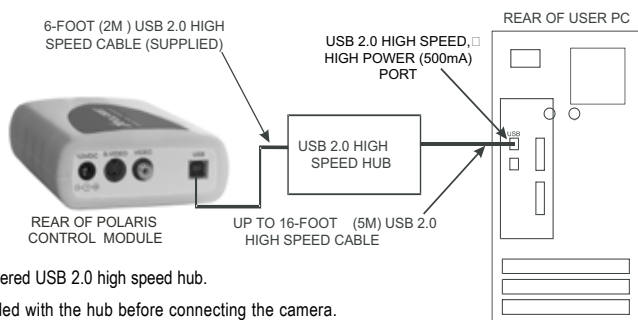

Use either a self-powered or bus-powered USB 2.0 high speed hub.

Follow installation instructions provided with the hub before connecting the camera.

Video Connection Options - Make connections as required by individual office equipment to connect the Polaris System video outputs.

1. S-Video. Using an optional 6-foot S-Video, 4-pin Mini DIN cable, connect between the S-VIDEO connector located on the rear of the Control Module and the associated connector of a video monitor or a computer with a capture card as required.
2. Composite Video. Connect the supplied composite video cable between the VIDEO RCA connector located on the rear of the Control Module and the associated RCA connector of a video monitor or a computer with a capture card as required.

Optional Video Connections

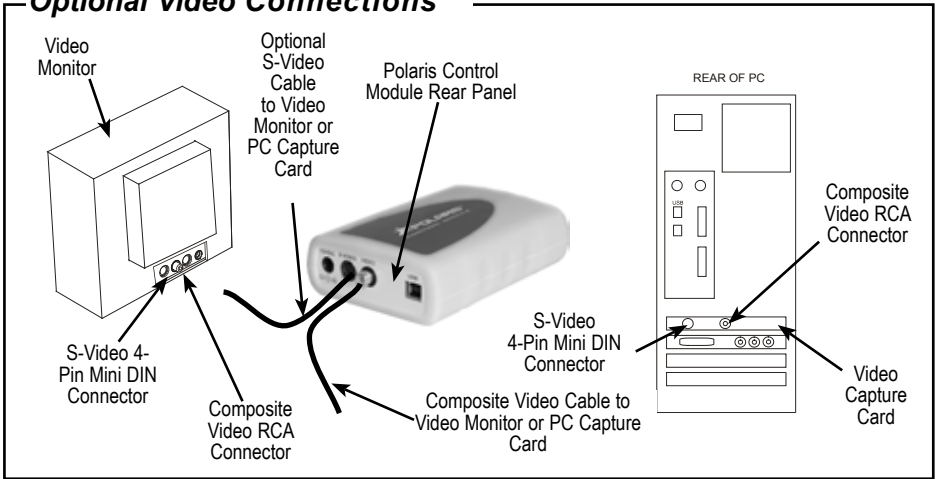

Operating Power Connection

- The Control Module receives operating power from the supplied Power Supply Adapter. Connect the dc power cord of the Power Supply Adapter to the 12 VDC connector located on the rear of the Control Module and then plug the Power Supply Adapter into an AC wall outlet.

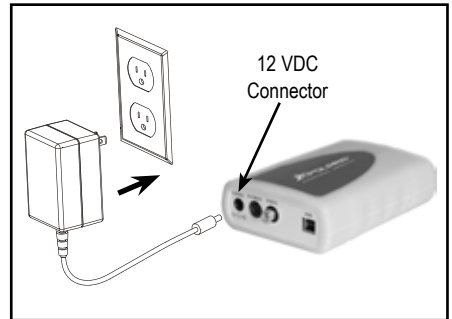

INSTALLATION

Notes: Authorized Imaging Software, such as VISIX, supplied by the dealer or other company, must be installed on the computer in order to operate the Polaris System.
A Microsoft® **Driver Not Signed** statement may appear. If it does, click **Continue** to proceed with installation.

USB Device Driver Installation - Before connecting the Polaris System to your computer or attempting to use it for the first time, run the Setup program on the Polaris System Drivers and Utilities Disk included with the Polaris System. The supplied CD provides the device drivers needed to communicate between the Polaris System and the associated user-supplied USB streaming video software application installed on the PC computer system. This must be completed before the Polaris System will operate properly. Normally, this program runs automatically when the CD is inserted into the drive for the first time. If not, run the setup program located in the root directory of the CD (typically **D:\Polaris.exe**).

Install the Standard Device Drivers by selecting Standard (default option) from the Setup program menu. If full device functionality is not present after the Standard Device Drivers are installed, the Legacy Device Drivers may need to be installed. More information can be found in the Installation Instructions and Notes file on the Polaris System Drivers and Utilities Disk included with the system.

CAMERA PORTABILITY



Do not twist or turn the Handpiece Cable connector. The connector is keyed and mates straight on with Camera Handpiece connector.

CAUTION: Always handle the Polaris Handpiece carefully. Do not drop and make sure to protect the optical window from scratches.

The Polaris Camera Handpiece quickly detaches from the Handpiece Cable and is easily carried among patient operatories for use with additional Polaris Camera System Control Modules. Refer to the corresponding illustrations and transport the Camera Handpiece as follows:

1. Retract collar of quick disconnect Handpiece Cable connector and simultaneously pull straight from the Handpiece connector.
2. Release connector quick disconnect collar.
3. Store the Handpiece Cable by placing cable slide holder into the Handpiece Holder.
4. Transport Handpiece to next operator.
5. Connect Handpiece at new location by aligning the connector key with the keyway of the mating Handpiece Cable connector.
6. Insert straight into Handpiece connector until it securely snaps into place.

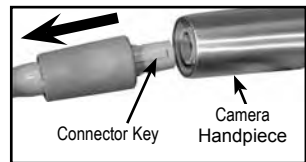

Detaching Handpiece

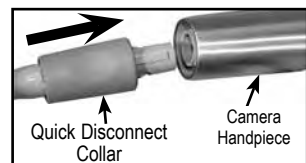

Connecting Handpiece

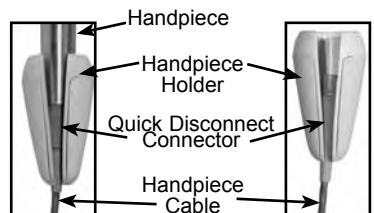

Polaris Handpiece Storing



The Polaris System should be used with a Camera Cover covering the handpiece. Make sure to use a new disposable Camera Cover for each patient.



The camera cover must be used for only one patient and disposed of properly in accordance with local code.

NOTE: For optimum image clarity, the optically clear section of the sheath must be aligned with the camera lens by facing the camera/light source section of the handpiece down toward the paper layer.

Disposable Camera Cover Installation - Install a new camera cover on the Camera Handpiece for each patient as follows:

1. Remove the Camera Handpiece from the holder.
2. Insert the Camera Handpiece tip between the second and third layers (between the outer paper and plastic layers) with the camera/light source facing towards the paper layer. See A.
3. Push the Camera Handpiece completely in until the tip is fully inserted into the narrow tip of the sheath. See B.
4. Gently squeeze the illuminated tip of the Camera Handpiece between the thumb and index finger to ensure that the optically clear area of the camera cover is flat against the lens tip. See C.
5. Peel away and discard the top plastic layer and the bottom paper layer. See D.

Camera Cover Installation

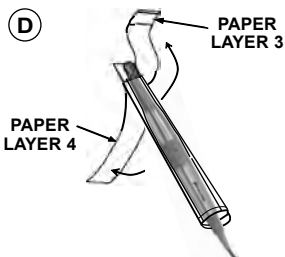
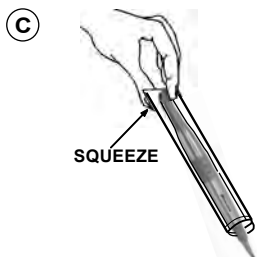
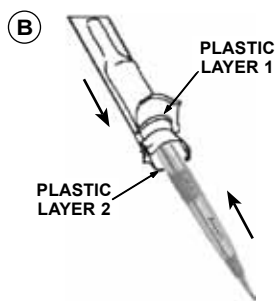
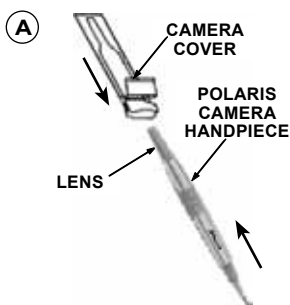

ACTIVATION

NOTE: When all camera system components are plugged into a single AC power strip, make sure that power strip is turned on. When camera system components are plugged into separate AC power outlets, make sure that each individual power outlet is turned on.

Power Turn On-Perform the following procedure as necessary to turn the power on for operation of the Polaris System.

1. Review the Installation Section as needed and make sure the Polaris System components are setup and connected for the applicable operating configuration.
2. If connecting to a computer system, turn on the computer and run the applicable video capture software. Make sure that the video capture software is set to display an NTSC (M) image with a 640 x 480 pixel resolution. If the video capture software supports a 2-button, joystick type footswitch, make sure that this software is set to enable and configure the buttons as needed.
3. If connecting to an analog video monitor, turn on the video monitor's power switch.
4. Turn on the Power switch on the control module front panel and verify that the power indicator LED illuminates green.
5. Remove the Camera Handpiece from the Handpiece Holder and verify that the camera's white LEDs illuminate.
6. If connecting to a computer system, verify that live video from the camera is correctly displayed on the computer monitor and also verify that the camera buttons perform the operations that apply to the video capture software that is being used. If not, follow the General USB Driver Check procedure provided below.
7. If connecting to an analog video monitor, verify that live video from the camera is correctly displayed on the video monitor.
8. Place the camera back into the handpiece holder and verify that the camera's white LEDs turn off.

SYSTEM OPERATION

Computer-Connected System Operation - The Polaris System is normally operated connected directly to a computer system running various PC USB streaming video capture software applications. In this configuration the camera provides the image/video source while the computer and associated software are used to display and save the resultant images. Perform the following procedures to operate the Polaris System when connected to a computer.



Make sure that the Polaris System and associated computer power is turned on.
Verify that the video capture software is running and correctly configured.

1. Activate the Polaris System by performing the Power Turn-On procedures described above.

2. Remove the Camera Handpiece from the handpiece holder and observe that the computer display shows the high-resolution live video images taken by the camera.
3. If desired, rotate the lens head left or right from center.
4. Place the camera lens window over area of interest and view image on computer display monitor.
5. Press and release the top keypad button on the Camera Handpiece to freeze (ie. capture) the displayed image on the computer monitor screen. The keypad button used may depend on the video capture software installed.
6. Press and release the bottom keypad button on the Camera Handpiece to save the captured image to the computer hard drive and then to return to a live image display. The keypad button used may depend on the video capture software installed.
7. Repeat steps 3 through 6 as necessary.
8. When imaging an X-ray film on a light box, deactivate the LED light source by depressing both Camera Handpiece buttons simultaneously for approximately 3 seconds. Perform steps 3 through 6 to freeze and save the X-ray film image as desired. Depress both Camera Handpiece buttons simultaneously for approximately 3 seconds to turn ON the LED light source as desired.
9. Return the Camera Handpiece to the holder when done. Verify that the LED light source and camera turns OFF.
10. Set the STANDBY/ON switch on the Control Module front panel to the STANDBY position and verify that the front panel LED indicator lamp extinguishes.

Monitor-Connected System Operation - The Polaris System can be operated directly connected to a video monitor. In this configuration the connected monitor displays high-resolution live video images taken by the camera. There is no computer system or software used to freeze and save the resultant images. Perform the following procedures to operate the Polaris System when connected to a video monitor.

1. Activate the Polaris System by performing the Power Turn-On procedures provided on page 18.
 2. Remove the Camera Handpiece from the Handpiece Holder and observe that the video monitor display shows the high-resolution live video images taken by the camera.
 3. If desired, rotate the lens head left or right from center. Place the camera lens window over area of interest and view image on display.
 4. When imaging an X-ray film on a light box, deactivate the LED light source by depressing both Camera Handpiece buttons simultaneously for approximately 3 seconds. Depress both Camera Handpiece buttons simultaneously for approximately 3 seconds to turn ON the LED light source as desired.
 5. Return the Camera Handpiece to the holder when done. Verify that the LED light source and camera turns OFF.
 6. Set the STANDBY/ON switch on the Control Module front panel to the STANDBY position and verify that the front panel LED indicator lamp extinguishes.
-

DIAGNOSTIC PROCEDURES

USB Video Diagnostic - If live video is not displayed on the PC monitor of the Polaris System when the imaging software application is running, there could be a problem with the settings in the software application or with the handpiece. Perform the following USB Video Diagnostic procedure to check that the Polaris handpiece is working correctly, the Polaris Handpiece Cable is correctly connected between the Polaris System and the computer and the Polaris System USB driver files are installed correctly on the PC.

1. Go to the **Start** button and select **Programs**.
2. Select the **Polaris** program option and click on **Camera Demonstration Program** and observe that the Camera Demonstration Program screen opens.
3. Depending on the outcome of the diagnostic, perform one of the following:
 - a. If a live image is correctly displayed, exit from the application and make sure that the imaging software application is configured correctly.
 - b. If a live image is not displayed, exit from the application and check the handpiece, Polaris Handpiece Cable and USB driver file installation.
4. Reset the driver's video settings by performing the following:
 - a. On the Polaris Demonstration Program screen, click the **Properties** button located on the lower left of the live image screen.
 - b. On the Properties screen select the **VIDEO PROC AMP** tab and then click the **DEFAULT** button. The image colors should now be correct. Click **OK** to close the Properties screen and exit from application.

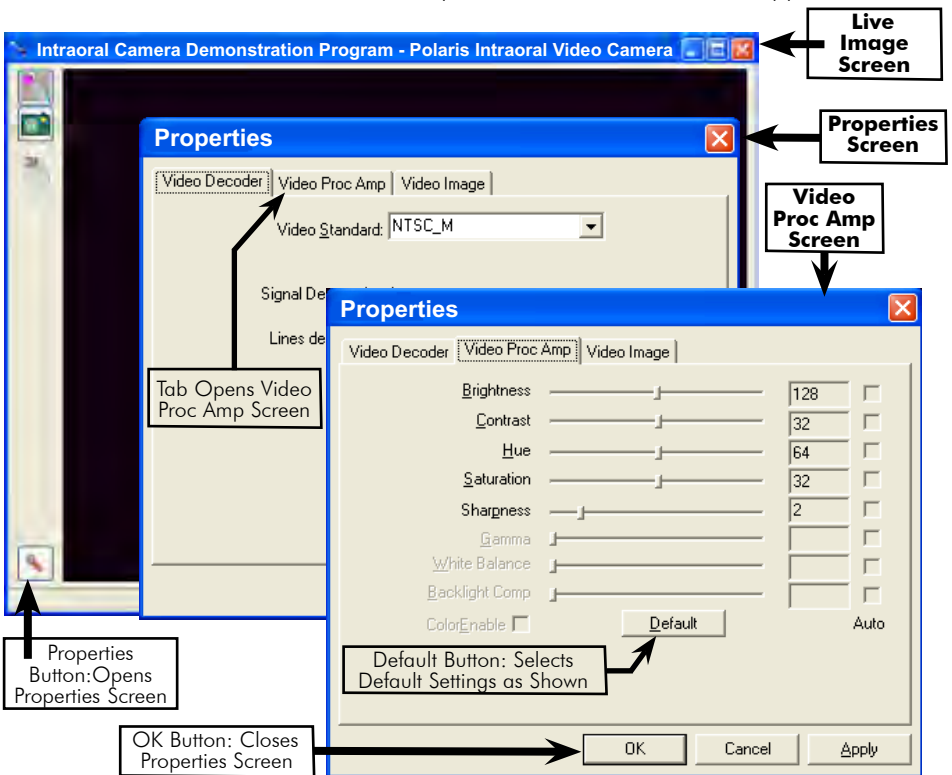

INSPECTION AND CLEANING

Perform the following inspection and cleaning procedures periodically as a preventive maintenance measure to keep the Polaris System in optimal condition resulting in trouble-free operation producing crisp, clear images.



Do not attempt any internal service of Polaris System components. Contact your local authorized Air Techniques dealer for service. Failure to heed this warning may result in equipment damage and voiding the warranty.

Inspection - Routinely inspect each component of the Polaris System for possible defects as follows:

1. Camera Handpiece -
 - a. Check overall handpiece for chips, cracks or other irregularities.
 - b. Check the lens window for debris or spots.
 - c. Check the connector socket for damage.
2. Control Module -
 - a. Check for broken indicator lamp and switch.
 - b. Check all connector sockets for damage, loose or missing hardware.
3. Cables and Connectors -
 - a. Check cables for damaged or deteriorated insulation kinking or twisting.
 - b. Check connectors for loose, bent or missing pins.
 - c. Check that both quick-disconnect plug ends snap closed to snugly secure the Handpiece Cable to the Camera Handpiece and Control Module connectors.

CAUTION: Always turn Off power and unplug the Polaris System components before performing cleaning procedures.



Do not spray cleaning liquids or disinfectants directly on the camera handpiece. Use care not to allow liquids to run into internal circuitry.

Do not wipe the surfaces using benzine, thinner, etc. as this may degrade the finish.

Do not autoclave the Camera Handpiece.



The camera cover must be used for only one patient and disposed of properly in accordance with local code.

Cleaning - Clean each component of the Polaris System as needed by performing the following procedures.

1. Control Module-Use a non-corrosive surface disinfectant such as Birex® se.
2. Camera Handpiece-Following every patient use, remove the camera cover from the Camera Handpiece and dispose in accordance with local regulations. The Camera Handpiece can be wiped clean and disinfected with any non-corrosive surface disinfectant such as Birex® se.
3. Camera Window Lens-Remove debris or spots from lens window by cleaning with alcohol and cotton swabs.

SPECIFICATIONS

External Adapter Voltage input:	100-240 Volts \pm 10%
Frequency:	50/60 Hz
Voltage Output:	12 VDC
(Optional adapter configurations available for international outlet usage.)	
Power Consumption:	7.2 watts
Video Outputs:	S-Video, Composite Video, High Speed USB 2.0
Sensor:	¼ Inch CCD
Format:	NTSC
Pixels:	768 H X 494 V
Resolution:	470 TV lines (Analog Video) 640 x 480 pixels (Digital Video)
Signal to Noise Ratio:	> 50 dB
Exposure Control:	Automatic
Illumination:	Ultra-bright white LED lamps
Image:	Normal, not mirrored
Viewing Angle:	42 Degrees horizontal
Operating Temperature:	10 to 40° C (50 to 104° F)
Storage Temperature:	0 to 70° C (32 to 158° F)
Humidity:	10 to 90% non-condensing
Classifications:	Portable, Continuous Operation, Class 2, Type BF
Protection for Ingress of Water:	Ordinary
Flammable Atmosphere:	Cannot use in the vicinity of flammable anesthetic mixtures of air, oxygen or nitrous oxide.
Device Class:	USA - 21CFR/Class I Canada - MDR/Class I,

Refer to page 9 for the minimum PC requirements

PHYSICAL CHARACTERISTICS

Dimensions	Length	Width	Height	Weight
Handpiece D7600:	8.3 inches (21.08 cm)	1.0 inches (2.54 cm)	0.9 inches (2.29 cm)	3.7 oz. (105 g)
Control Module D7565:	5.7 inches (14.5 cm)	3.9 inches (9.9 cm)	1.6 inches (4.06 cm)	8.1 oz. (251 g)
Handpiece Cable D7540-15:	15 feet (4.57 m)			

The following lists the ordering number and description for accessory components available to maintain and expand the Polaris System to meet your professional needs.

Contact your Air Techniques Dealer for information.

Polaris Camera System

Order Number	Description
D7500	Complete Polaris Universal Intraoral Video Camera System
D7520	Polaris Camera Handpiece Assembly
D7560	Polaris Control Module
A5135	Wall-Mounted Power Supply Adapter
D7540-15	15-foot Multi-Conductor Camera Handpiece Cable Assembly
77389	6-foot Composite Video Cable, RCA/RCA
B3554	6-foot USB 2.0 High Speed Cable, Type A/Type B
D7170	Camera Handpiece Holder with Chair-side Adapter
D7563	Drivers and Manual CD containing - PDF version of Operator's Manual USB Device Drivers Demonstration Program and Utilities Adobe Acrobat Reader
74500	VISIX Imaging Software, 5 Licenses, see page 24.

Replacement Disposable Camera Covers for Camera Handpiece

D7125	Box of 100
D7120	Box of 500

Optional Multi-Conductor Camera Handpiece Cable Assemblies

D7540-6	6-Foot Length Cable Assembly
D7540-9	9-Foot Length Cable Assembly
D7540-30	30-Foot Length Cable Assembly
D7540-50	50-Foot Length Cable Assembly
77379	6-foot S-Video, 4-Pin Mini DIN/4-pin Mini DIN Cable

Consider VISIX, our new comprehensive digital imaging software application, providing seamless integration with our digital imaging suite; the Accent CCD Intraoral Sensor, ScanX PSP Systems and Polaris Intraoral Cameras.

Key Features.

- Easy to learn.
- Simple to use.
- Acquire, mount, view and store images with just a few mouse clicks.
- Customize images to personal preferences with our simple Set-Up 1-2-3 tool.
- Exposure - Our Stop Light Exposure System is a unique indicator to ensure optimum data capture. It helps you acquire great images by monitoring X-ray exposure.
- Viewing - VISIX provides automatic image mounting that is completely customizable.
- Flexibility - VISIX includes a built-in bridging solution to over 35 Practice Management Software titles.

VISIX is the superb software complement for Polaris. Contact your authorized dealer for further information.

This Air Techniques equipment is warranted to be free from defects in material and workmanship from the date of installation for a period of 3 years.

Any item returned to our factory through your authorized Air Techniques dealer, will be repaired or replaced at our option at no charge provided that our inspection shall indicate it to have been defective. Dealer labor, shipping and handling charges are not covered by this warranty.

This warranty does not apply to damage due to shipping, misuse, careless handling or repairs by other than authorized service personnel. Warranty void if installed or serviced by other than your authorized Air Techniques dealer service personnel. Air Techniques, Inc. is not liable for indirect or consequential damage or loss of any nature in connection with this equipment. This warranty is in lieu of all other warranties expressed or implied. No representative or person is authorized to assume for us any liability in connection with the sale of our equipment.

ON-LINE WARRANTY REGISTRATION

Quickly and easily register the Polaris Camera on-line. Just have your product model and serial numbers available. Then go to the Air Techniques web site, **www.airtechniques.com**, click the **warranty registration** link and complete the registration form. This on-line registration ensures a record for the warranty period and helps us keep you informed of product updates and other valuable information.

Air Techniques is a leading manufacturer of dental products including air and vacuum systems, film processors, digital imaging systems and intra-oral digital video systems. We have been manufacturing quality products for dental professionals since 1962.

Air Techniques' products are only distributed through authorized dealers.

- A/T 2000[®] XR
- Acadia[™]
- Accent[™]
- AirStar[®]
- CleanStream[™]
- Guardian[™]
- Peri-Pro[®]
- Polaris[™]
- ScanX[®]
- Sensa[™]
- Spectra[™]
- STS[™]
- VacStar[™]
- Visix[™]



1295 Walt Whitman Road, Melville, NY 11747-3062

Website: www.allproimaging.com

East Coast: 1-800-AIR-TECH (1-800-247-8324) • West Coast: 1-800-822-2899