

ScanX Intraoral View

ScanX Classic View

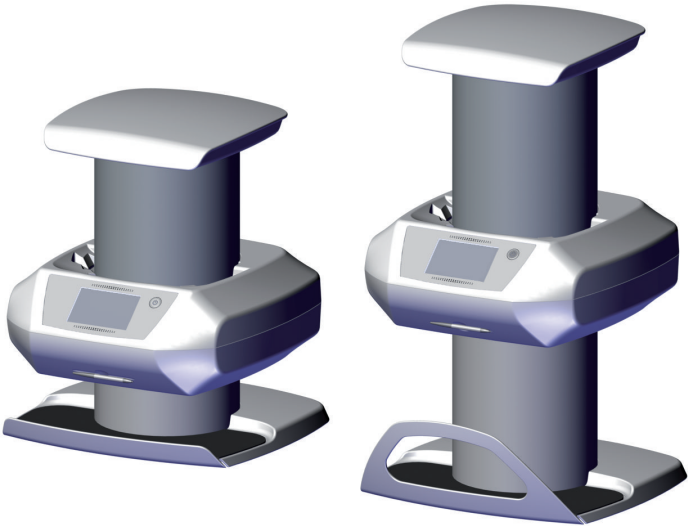

EN-US Installation and Operating Instructions



RxOnly



2151100018L29 G8602 2511V019

The latest version of the instructions is available in this page:



<https://bit.ly/m/air-techniques-imaging-manuals>

Contents



Important information

1	About this document	3
1.1	Warnings and symbols	3
1.2	Copyright information	4
2	Safety	5
2.1	Intended use (FDA)	5
2.2	General safety information	5
2.3	Specialist personnel	5
2.4	Protection from electric shock	6
2.5	FCC note	6
2.6	Notification requirement of serious incidents	6
2.7	Only use genuine parts	6
2.8	Transport	7
2.9	Disposal	7
2.10	Protection from cybersecurity threats	7



Product description

3	Overview	8
3.1	Scope of delivery	9
3.2	Accessories	10
3.3	Optional items	10
3.4	Consumables	10
3.5	Wear parts and spare parts	10
4	Technical data	11
4.1	Phosphor storage plate scanner	11
4.2	Phosphor storage plate	13
4.3	Barrier envelope	13
4.4	Model identification plate	14
4.5	Conformity assessment	14
5	Function	14
5.1	Phosphor storage plate scanner	14
5.2	Phosphor storage plate	16
5.3	Barrier envelope	16
5.4	Stylus	16
5.5	Transfer box	16



Installation

6	Requirements	18
6.1	Installation/setup room	18
6.2	Monitor	19
7	Installation	20
7.1	Carrying the unit	20
7.2	Setting up the unit	21
7.3	Assembling the support bracket	22
7.4	Removing the protective film from the touch screen	24
7.5	Attaching the Stylus	24
7.6	Checking the memory card	24
7.7	Electrical connection	25
7.8	Connecting the unit to the network	25
8	Commissioning and first start-up	26
8.1	Configuring the network	26
8.2	Configuring the unit in VistaSoft	27
8.3	Prepare the X-ray cassette for an extraoral phosphor storage plate	28
8.4	X-ray unit settings	29
8.5	Commissioning tests	30



Usage

9	Operating the touch screen	32
9.1	Navigating	32
9.2	Using menus	32
9.3	Entering text in a field	32
9.4	Calling up messages on the touch screen	33
10	Correct use of phosphor storage plates	33
11	Operation	35
11.1	Replacing the plate guide	35
11.2	X-ray	35
11.3	Scanning the image data via a computer	39
11.4	Scanning image data via the touch screen on the unit	41

- 11.5 Erasing the phosphor storage plate 44
- 11.6 Switching the unit off 44
- 12 Cleaning and disinfection 44**
 - 12.1 Phosphor storage plate scanner 44
 - 12.2 Plate guide 45
 - 12.3 Barrier envelope 45
 - 12.4 Phosphor storage plate 45
 - 12.5 Plate protector 45
 - 12.6 Stylus 46
- 13 Maintenance 47**
 - 13.1 Recommended maintenance schedule 47
 - 13.2 Check image quality 47



Troubleshooting

- 14 Tips for operators and service technicians 50**
 - 14.1 Poor X-ray image 50
 - 14.2 Software error 53
 - 14.3 Fault on the unit 55
 - 14.4 Error messages on the touch screen 56



Appendix

- 15 Menu structure Settings 58**
- 16 Scanning times 61**
 - 16.1 Intraoral 61
 - 16.2 Extraoral Panoramic 61
 - 16.3 Extraoral Ceph 61
- 17 File sizes (uncompressed) 62**
 - 17.1 Intraoral 62
 - 17.2 Extraoral Panoramic 62
 - 17.3 Extraoral Ceph 62
- 18 Warranty 63**
 - 18.1 Online Warranty Registration 63

Important information

1 About this document

These installation and operating instructions are an integral part of the unit.



Air Techniques shall not be held liable and offers no guarantees of the safe and smooth operation of this unit if you fail to comply with notes and instructions contained in these Installation and Operating Instructions.

The German version of the installation and operating instructions is the original manual. All other languages are translations of the original manual. These operating instructions are valid for the following ScanX Intraoral View, order number G8600A (2151100011) and ScanX Classic View, order number G8700A (2151110010).

1.1 Warnings and symbols

Warnings

The warning notes in this document highlight possible injury to persons or damage to machinery.

They are marked with the following warning symbols:



General warning symbol

The warnings are structured as follows:



SIGNAL WORD

Description of type and source of danger

Here you will find the possible consequences of ignoring the warning

- › Follow these measures to avoid the danger.

The signal word differentiates between different levels of danger:

- **DANGER**
Direct danger of severe injury or death
- **WARNING**
Possible danger of severe injury or death
- **CAUTION**
Risk of minor injuries
- **NOTICE**
Risk of extensive material/property damage

Miscellaneous symbols

These symbols are used in the document and on or in the unit:



Note, e.g. specific instructions regarding the efficient use of the unit.



CE mark



CE labeling with the number of the notified body



ETL Certification
CONFORMS TO UL STD 61010-1
CERTIFIED TO CAN/CSA STD C22:2 NO 61010-1



Manufacturer



Date of manufacture



Distributor



Dispose of correctly in accordance with EU Directive 2012/19/EU (WEEE).



Do not reuse



Wear hand protection.



Disconnect all power from the unit.



Please note the operating instructions.



Take note of the accompanying electronic documents.



Part number



Serial number



Medical device





Health Industry Bar Code (HIBC)



Batch name

 Warning – risk of dangerous electric voltages

 Warning - laser beams

 Lower and upper temperature limits

 Upper temperature limit

 Lower and upper humidity limits

 Keep dry

 This way up / store and transport in an upright position

 Fragile, handle with care

 Keep away from sunlight during storage

 Stacking limits

 Do not roll

 Recycling

Adhesive label

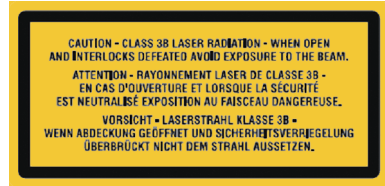
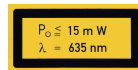

Fig. 1: Laser class 3B



Fig. 2: Warning - laser beams



Specification of laser source

1.2 Copyright information

All electronic drawings, processes, names, software, and appliances mentioned here are protected under copyright.

Printing or copying these Installation and Operating Instructions, including excerpts thereof, may only be carried out with the written approval of Air Techniques.

2 Safety

The unit has been developed and designed appropriately such that hazards are largely excluded if the unit is used in accordance with its Intended use.

Therefore, please note the following.

Despite this, the following residual risks can remain:

- Personal injury due to incorrect use/misuse
- Personal injury due to mechanical effects
- Personal injury due to electric shock
- Personal injury due to radiation
- Personal injury due to fire
- Personal injury due to thermal effects on the skin
- Personal injury due to lack of hygiene, e.g. infection

2.1 Intended use (FDA)

ScanX Intraoral View / ScanX Classic View

Indications for use

The ScanX Intraoral View is intended to be used for scanning and processing digital images exposed on Phosphor Storage Plates (PSPs) in dental applications.

The ScanX Classic View is intended to be used for scanning and processing digital images exposed on Phosphor Storage Plates (PSPs) in dental applications.

Contraindication

Any other usage or usage beyond this scope is deemed to be improper. The manufacturer accepts no liability for damage resulting from improper usage. The user bears the sole risk. The unit is not designed for operation within the patient environment.

This unit is not suitable for monitoring patients over extended periods of time.

This unit must not be used in operating rooms or similar rooms, in which hazards may arise from the combustion of flammable materials.

The touch screen only shows a preview as an initial impression of the X-ray image. For purposes of diagnosis, the X-ray image must be viewed on a diagnostic monitor. The preview of the X-ray image on the touch screen is not suitable for the purposes of diagnosis.

Barrier envelope

Indication for use

Disposable Barrier Envelopes are intended to be used as a disposable barrier for Air Techniques Phosphor Storage Plates. This device is non-sterile and intended for single patient use only.

Contraindication

This Device has no contraindications.

2.2 General safety information

The sale or prescription of this device by a medical practitioner is subject to the restrictions of the applicable Federal Acts. The device may be used only under permanent supervision by a dentist or licensed medical practitioner.

Rx_{only} Caution: By virtue of Federal Law (US-FDA 21CFR801.109), the device may only be sold to dentists or bought on behalf of a dentist.

- Always comply with the specifications of all guidelines, laws, and other rules and regulations applicable at the site of operation for the operation of this unit.
- Check the function and condition of the unit prior to every use.
- Do not convert or modify the unit.
- Comply with the specifications of the Installation and Operating Instructions.
- The Installation and Operating Instructions must be accessible to all operators of the unit at all times.

2.3 Specialist personnel

Operation

Persons who operate the units must ensure safe and correct handling based on their training and knowledge.

- Instruct or have every user instructed in handling the unit.

Installation and repairs

- The manufacturer recommends that installation, readjustments, alterations, upgrades and repairs be carried out either by the manufacturer itself or by qualified personnel authorized by the manufacturer.

2.4 Protection from electric shock

- Comply with all the relevant electrical safety regulations when working on the unit.
- Never touch the patient and unshielded plug connections of the device at the same time.
- Replace damaged cables or plugs immediately.

Comply with the EMC rules concerning medical devices

The device is designed for use in a basic electromagnetic environment in accordance with IEC 61326-1.

2.5 FCC note

This device has been tested and complies with the limits for a class B digital device as set out in part 15 of the FCC regulations. These limits are designed to provide adequate protection against harmful interference in residential environments. This device generates, uses, and can emit high-frequency energy, and it can cause harmful interference to wireless communication systems if it is not installed and used in accordance with the instructions. However, this statement does not offer a guarantee that no interference will occur in a certain installation. If this device causes harmful interference to radio or TV reception (this can be tested by switching the device off and back on again), users are recommended to attempt to eliminate the interference by taking one or more of the following measures:

1. Realign or reposition the reception aerial.
2. Increase the distance between the device and the receiver.
3. To meet FCC requirements on HF exposure compliance, a safety distance of at least 20 cm must be maintained between the device's internal aerial and all persons.
4. Connect the device to a power outlet on a different circuit to the one the receiver is connected to.
5. Consult a dealer or experienced radio/TV technician.

2.6 Notification requirement of serious incidents

The user / patient is required to report to the manufacturer and the competent authority of the Member State in which the user and/or patient is established any serious incident that has occurred in relation to the device.



Report any serious incidents to the manufacturer under incidents@duerrdentel.com.

2.7 Only use genuine parts

1. Only use accessories and optional items specified or approved by Air Techniques.
2. Only use original working parts and spare parts.



Air Techniques accepts no liability for damage resulting from the use of non-approved accessories, optional items or any parts other than original spare and wear parts.

The use of non-approved accessories, optional items or non-genuine wear parts / replacement parts (e. g. mains cable) can adversely affect the electrical safety and EMC.

2.8 Transport

The original packaging provides optimum protection for the unit during transport.

If required, original packaging for the unit can be ordered.



Manufacturer and distributor shall not accept any responsibility or liability for damage occurring during transport due to the use of faulty packaging, even where the unit is still under guarantee.

- Only transport the unit in its original packaging.
- Keep the packing materials out of the reach of children.
- Do not expose the unit to any strong vibrations or shocks.

2.9 Disposal

Disposal of the units, electronic circuitry and PSPs must be accomplished only at the appropriate facilities for recovery and recycling. Make sure to dispose of such items in accordance with current federal, national, state and local government rules and regulations.

2.10 Protection from cybersecurity threats

The unit is to be connected to a computer that can be connected to the Internet. Therefore, the system needs to be protected from threats from the Internet.

- Use antivirus software and update it regularly.
- Look for evidence of possible virus infection and, if applicable, check with the antivirus software and remove the virus.
- Perform regular data backups.
- Restrict access to units to trustworthy users, e.g. via a user name and password.
- Make sure that only trustworthy content is downloaded. Install manufacturer-authenticated software and firmware updates only.

Product description

3 Overview

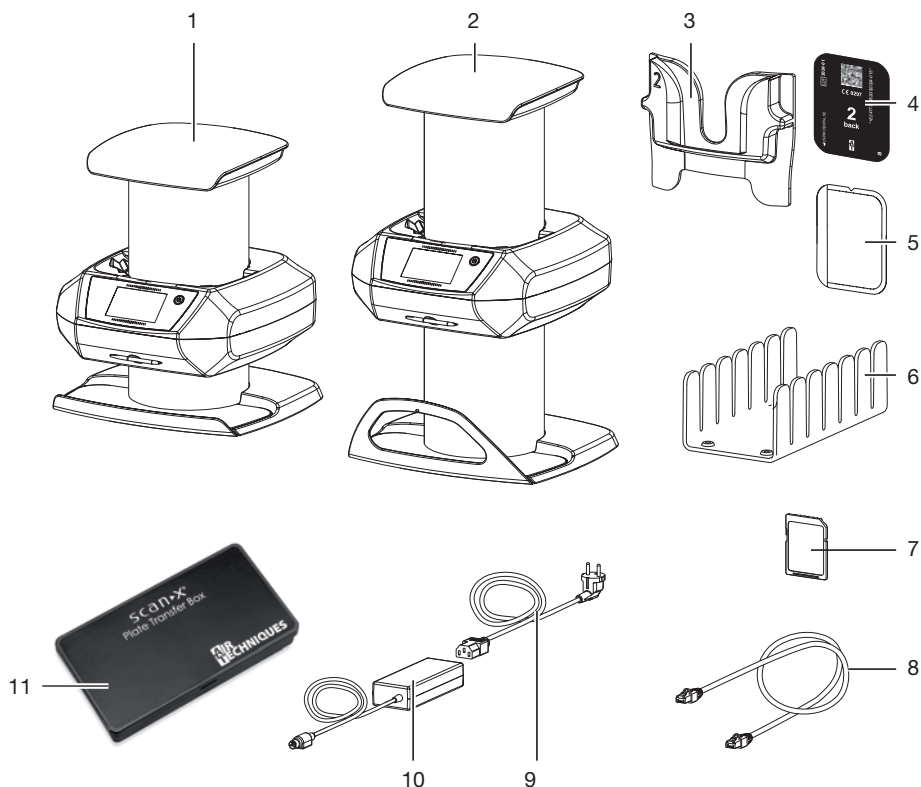

- | | | | |
|---|---|----|-------------------|
| 1 | ScanX Intraoral View phosphor storage plate scanner | 7 | SDHC memory card |
| 2 | ScanX Classic View phosphor storage plate scanner | 8 | Network cable |
| 3 | Plate guide intraoral | 9 | Mains cable |
| 4 | Intraoral phosphor storage plate (PSP) | 10 | Power supply unit |
| 5 | Barrier envelope intraoral | 11 | Transfer box |
| 6 | Holding tray for intraoral plate guide | | |

3.1 Scope of delivery

The following items are included in the scope of delivery (possible variations may apply due to country-specific requirements and/or import regulations):

ScanX Intraoral View

Phosphor storage plate scanner system G8600A

- ScanX Intraoral View basic unit
- Network cable
- SDHC memory card
- Stylus
- Collector mat
- Collector bar
- Power supply
- Power Cable
- Voucher for VistaSoft imaging software
- Holder for intraoral plate guides
- Transfer box
- Phosphor storage plates:
 - Size 0
 - Size 2
- Plate guides:
 - Size 0
 - Size 2
- Barrier envelopes:
 - Size 0
 - Size 2
- Phosphor storage plate cleaning wipes
- Installation and Operating Instructions
- Quick Start Instructions

ScanX Classic View

Phosphor storage plate scanner system G8700A

- ScanX Classic View basic unit
- Network cable
- SDHC memory card
- Stylus
- Collector mat
- Collector bar
- Power supply
- Power Cable
- Voucher for VistaSoft imaging software
- Holder for intraoral plate guides
- Transfer box
- PSPs
 - Size 0
 - Size 2
- Plate guides:
 - Size 0
 - Size 2
- Barrier envelopes:
 - Size 0
 - Size 2
- Phosphor storage plate cleaning wipes
- Installation and Operating Instructions
- Quick Start Instructions

3.2 Accessories

The following items are required for operation of the device, depending on the application:
SDHC memory card G8590

Phosphor storage plates (PSPs)

- Intraoral phosphor storage plate size 0 (2 pcs.) 73445-0
- Intraoral phosphor storage plate size 1 (2 pcs.) 73445-1
- Intraoral phosphor storage plate size 2 (4 pcs.) 73445-2
- Intraoral phosphor storage plate size 3 (2 pcs.) 73445-3
- Intraoral phosphor storage plate, size 4 (1 pcs.) 73445-4
- Extraoral PSP phosphor storage plate for Panoramic 5" x 12" (1 pc.) 73578-5F
- Extraoral PSP phosphor storage plate for Panoramic 15 cm x 30 cm (1 pc.) 73578-6F
- Extraoral PSP phosphor storage plate for Ceph 8" x 10" (1 pc.) 73578-8F
- Extraoral PSP phosphor storage plate for TMJ 5" x 7" (1 pc.) 73578-57F

Barrier envelopes

- Barrier envelope, size 0 (100 pc.) 73248-0
- Barrier envelope, size 1 (100 pc.) 73248-1
- Barrier envelope, size 2 (300 pc.) 73248-2
- Barrier envelope, size 2 (1000 pc.) 73248-2k
- Barrier envelope, size 3 (100 pc.) 73248-3
- Barrier envelope, size 4 (50 pc.) 73248-4

3.3 Optional items

- The following optional items can be used with the device:
- Transfer box 73470
 - Holding tray for intraoral plate guides G8620
 - Network cable (5 m) G8595
 - Stylus G8585
 - 2D X-ray test phantom G8795
 - VistaPosition PSP Anterior/Posterior Kit Titanium G3710
 - VistaPosition PSP Anterior/Posterior Kit G3810
 - VistaPosition PSP Bitewing Kit Titanium G3720

- VistaPosition PSP Bitewing Kit G3820
- VistaPosition PSP Endo Kit Titanium G3730
- VistaPosition PSP Endo Kit G3830

Commissioning and intraoral constancy tests

- 2D X-ray test phantom G8795

3.4 Consumables

The following materials are consumed during operation of the device and must be re-ordered:

Cleaning and disinfection

- PSP cleaning wipes (50 pieces) B8910

Barrier envelopes

refer to "3.2 Accessories"

3.5 Wear parts and spare parts

Phosphor storage plates (PSPs)

refer to "3.2 Accessories"

Plate guides

- Plate guide Size 0 (1 pc.) G8610-0N
- Plate guide Size 1 (1 pc.) G8610-1N
- Plate guide Size 2 (1 pc.) G8610-2N
- Plate guide Size 3 (1 pc.) G8610-3N
- Plate guide Size 4 (1 pc.) G8610-4N

Plate protector

- Plate protector Size 5" x 12" G8715
- Plate protector Size 15 cm x 30 cm G8716
- Plate protector Size 8" x 10" G8717
- Plate protector Size 5" x 7" G8718

4 Technical data

4.1 Phosphor storage plate scanner

Electrical data of the device		
Voltage	V DC	24
Max. current consumption	A	5
Output	W	< 120
Electrical data of the power supply unit		
Rated voltage	V AC	100 - 240
Frequency	Hz	50/60
General technical data		
Dimensions of the ScanX Intraoral View (W x H x D)	cm	38 x 45 x 41
	in	14.96 x 17.72 x 16.14
Dimensions of the ScanX Classic View (W x H x D)	cm	38 x 63 x 41
	in	14.96 x 24.80 x 16.14
Weight of the ScanX Intraoral View	kg	approx. 19.5
	lb	approx. 43
Weight of the ScanX Classic View	kg	approx. 21
	lb	approx. 46.3
Max. phosphor storage plate feeding width of the ScanX Intraoral View	cm	5.7
	in	2.24
Max. phosphor storage plate feeding width of the ScanX Classic View	cm	30
	in	11.81
Duty cycle S2 (in accordance with IEC 60034-1)	min	60
Duty cycle S6 (in accordance with IEC 60034-1)	%	70
Max. theoretical resolution	Line pairs/mm (Lp/mm)	approx. 40
Noise level		
Standby	dB(A)	0
Ready to scan	dB(A)	approx. 37
During scanning	dB(A)	approx. 55
Network connection		
LAN technology		Ethernet
Standard		IEEE 802.3u
Data rate	Mbit/s	100
Connector		RJ45

Network connection

Type of connection	Auto MDI-X
Type of cable	≥ CAT5

WiFi connection

WiFi technology	IEEE 802.11b/g
Encryption	WPA, WPA2

Ambient conditions during operation

Temperature	°C	+10 to +35
	°F	+50 to +95
Relative humidity	%	20 - 80
Air pressure	hPa	750 - 1060

Ambient conditions during storage and transport

Temperature	°C	-20 to +60
	°F	-4 to +140
Relative humidity	%	10 - 95
Air pressure	hPa	750 - 1060

Classification

Medical Device Class (MDR)	I
FDA classification (CFR Title 21)	II
Laser class (unit) in accordance with IEC 60825-1:2014	1

Laser source

Laser class in accordance with IEC 60825-1:2014	3B	
Wavelength λ	nm	635
Output	mW	≤ 15

Memory card

Type	SDHC	
Maximum memory capacity	GB	32
File system	FAT32	
Performance class	Class	≥ 4

4.2 Phosphor storage plate

Classification

Medical Device Class (MDR)	IIa
FDA classification (CFR Title 21)	I

Ambient conditions during operation

Temperature	°C	18 - 45
	°F	64 - 113
Relative humidity	%	< 80

Ambient conditions during storage and transport

Temperature	°C	< 45
	°F	< 113
Relative humidity	%	< 80

Dimensions of phosphor storage plates

S0	mm	22 x 35
	in	0.87 x 1.38
S1	mm	24 x 40
	in	0.94 x 1.57
S2	mm	31 x 41
	in	1.22 x 1.61
S3	mm	27 x 54
	in	1.06 x 2.13
S4	mm	57 x 76
	in	2.24 x 2.99

Dimensions of extraoral PSPs

Panoramic 5" x 12"	mm	125 x 286
	in	4,92 x 11,25
Panoramic 15 cm x 30 cm	mm	148 x 298
	in	5,82 x 11,73
Ceph 8" x 10"	mm	202 x 241
	in	7,95 x 9,49
TMJ 5" x 7"	mm	127 x 177
	in	5 x 7

4.3 Barrier envelope

Classification

Medical Device Class (MDR)	I
FDA classification (CFR Title 21) Class	II

4.4 Model identification plate

The model identification plate is located underneath the rubber mat of the base plate of the unit.

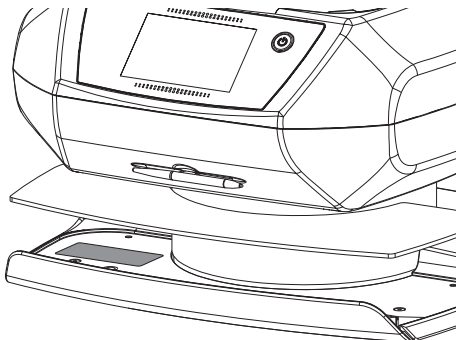

4.5 Conformity assessment

This device has been subjected to conformity acceptance testing in accordance with the current relevant guidelines of the European Union. This equipment conforms to all relevant requirements.

5 Function

5.1 Phosphor storage plate scanner

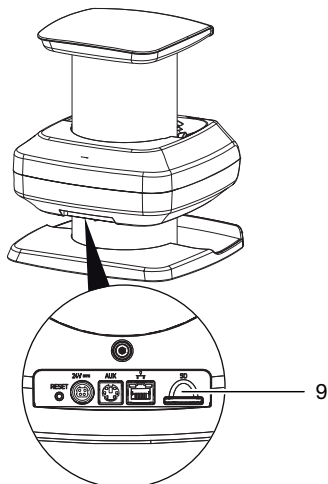
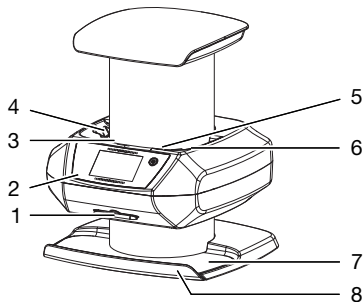

- 1 Stylus
- 2 Operating elements
- 3-6 Insertion slots
- 7 Collector mat
- 8 Collector bar
- 9 Memory card slot

The phosphor storage plate scanner is used to read image data stored on the phosphor storage plate.

The unit can be used in two different ways: via the imaging software (e.g. VistaSoft) on a PC or directly via the touch screen on the unit.

The transport mechanism guides the phosphor storage plate through the device. The phosphor storage plate is read using a laser inside the scanner unit. The scanned data is converted into a digital image.

If a scanning job is started via the imaging software, the image is automatically transmitted to the computer.

If a scanning job is started via the touch screen, the image is saved to the memory card and needs to be transferred to the computer later on. After scanning, the phosphor storage plate runs through the erasure unit. Image data still held on the phosphor storage plate is erased with the aid of bright light.

The phosphor storage plate is then ejected for re-use.

The unit can scan up to four PSPs simultaneously at the same resolution.

Operating elements

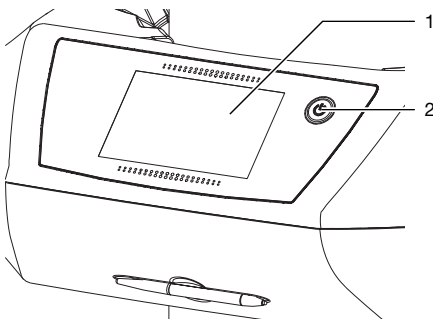

- 1 Touch screen
- 2 On/off switch

The touch screen allows the unit to be operated when it is not connected to a computer. Instructions can be entered on the touch screen either with the tip of a finger or the Stylus.

The **Help** button can be used to open a help page for the respective page. The **Messages** button can be used to call up current messages.

Connections

The connections are located on the rear of the unit.

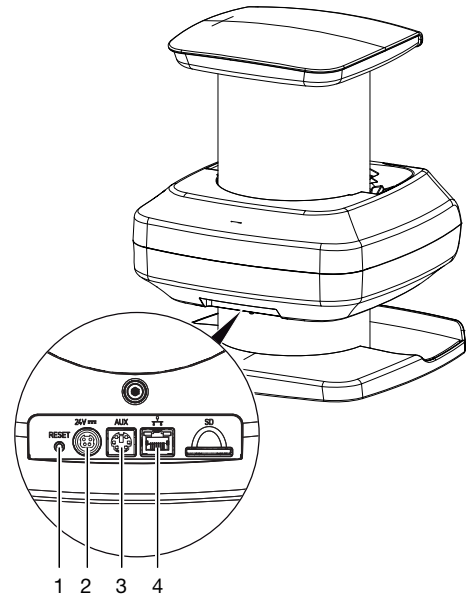

- 1 Reset button
- 2 Connection for power supply unit
- 3 AUX connection for diagnostic units
- 4 Network connection with status LED

ScanManager

When the ScanManager is enabled, more than one X-ray job can be transmitted simultaneously to the unit from different computers. The unit manages the X-ray jobs in a queue from which the respective X-ray job can be selected using the touch screen and then executed.

Without ScanManager, the unit processes one X-ray job at a time and is blocked until this job has been completed. During this time, no further X-ray jobs can be transmitted to the unit from other computers.



ScanManager can be enabled via **Settings > System Settings > Operating Type**.

5.2 Phosphor storage plate

The PSP stores X-ray energy, which is re-emitted in the form of light after excitation by the laser. This light is then converted into image information in the phosphor storage plate scanner. The PSP has an active side and an inactive side. The PSP must always be exposed on the active side.

When used properly, a PSP can be exposed, read and erased several hundred times provided there is no mechanical damage. The PSP must be replaced if there are any signs of damage, e.g. if the protective layer is damaged or there are visible scratches that could interfere with the diagnostics.

Intraoral

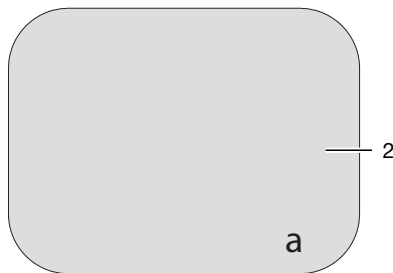

- | | | |
|---|---------------|--|
| 1 | Inactive side | Black, size and manufacturer information printed on it |
| 2 | Active side | Light blue, with positioning aid a |

Positioning aid **a** is visible on the x-ray image and makes orientation easier during diagnosis.

Extraoral

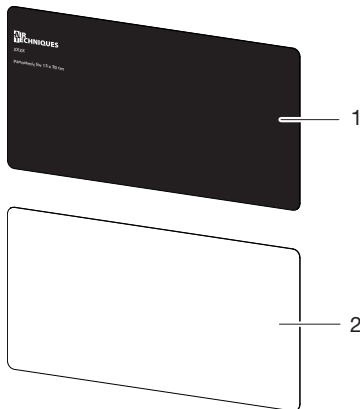

- | | | |
|---|---------------|--|
| 1 | Inactive side | black, with manufacturer's information printed on it |
| 2 | Active side | white |

5.3 Barrier envelope

Disposable Barrier Envelopes are intended to be used as a disposable barrier for Air Techniques Phosphor Storage Plates. This device is non-sterile and intended for single patient use only.

5.4 Stylus

The touch screen can be operated using the Stylus as an alternative to the tip of a finger.

5.5 Transfer box



Protects the PSP during day-to-day use and storage.

The transfer box also protects the PSPs against the light source when these are moved from the patient to the unit.



Only qualified specialists or persons trained by Air Techniques may install, connect, and commission the unit.

6 Requirements

6.1 Installation/setup room

The room chosen for set up must meet the following requirements:

- Closed, dry, well-ventilated room
- It should not be a room made for another purpose (e.g. boiler room or wet cell)
- Max. light intensity 1000 Lux, no direct sunlight at the place of installation of the unit
- There should be no major fields of interference (e.g. strong magnetic fields) present that can interfere with the proper operation of the unit.
- Ambient conditions correspond to "4 Technical data".
- Installation location outside the vicinity of patients

6.2 Monitor

The monitor must meet the requirements for digital X-ray with a high light intensity and wide contrast range.

Strong ambient light, sunlight impinging directly onto the monitor and reflections can make it more difficult or even impossible to perform a diagnosis based on the X-ray images.

7 Installation

7.1 Carrying the unit



NOTICE

Damage to sensitive components of the unit due to shocks or vibrations

- › Do not expose the unit to any strong vibrations or shocks.
- › Do not move the unit during operation.

ScanX Intraoral View

1. Carry the appliance by the sides of its housing only.

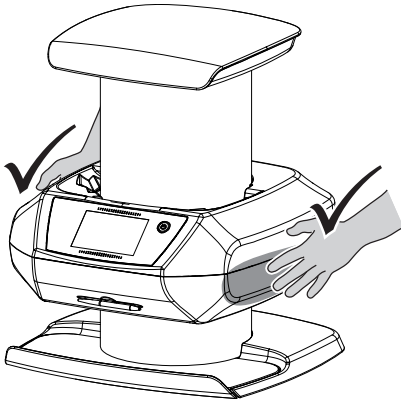

2. Do not hold or apply pressure to the cover or collector bar.

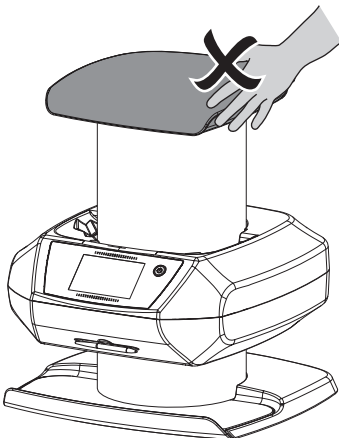

3. Do not carry the unit on its side.

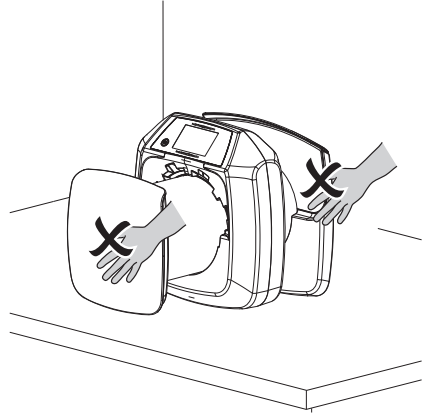

ScanX Classic View

1. Carry the appliance by the sides of its housing only.

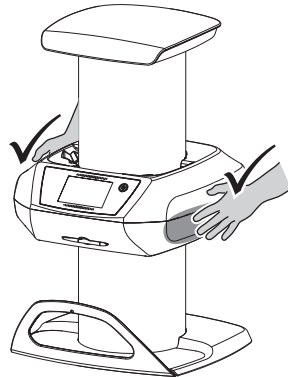

2. Do not hold or apply pressure to the cover or collector bar.

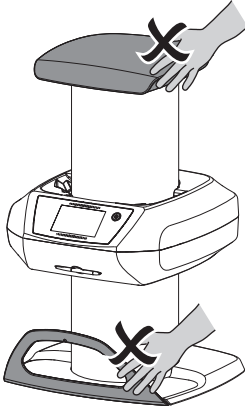

3. Do not carry the unit on its side.

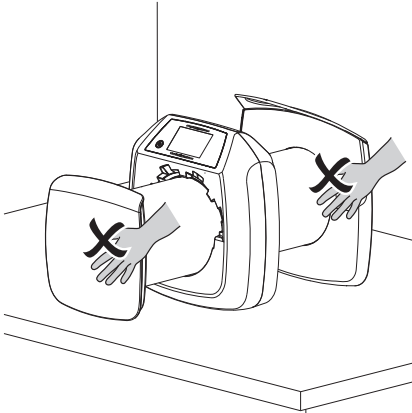

7.2 Setting up the unit



NOTICE

Damage to sensitive components of the unit due to shocks or vibrations

- › Do not expose the unit to any strong vibrations or shocks.
- › Do not move the unit during operation.

Portable and mobile HF communication devices can interfere with the effectiveness of electrical medical devices.

The unit can be set up as a tabletop unit.

The load-bearing capacity of the table must be suitable for the weight of the unit (see "4 Technical data").

Setting the unit on a table



To prevent errors when scanning the image data, install the unit so it is not exposed to vibrations.

1. Place the unit on a firm, horizontal surface.

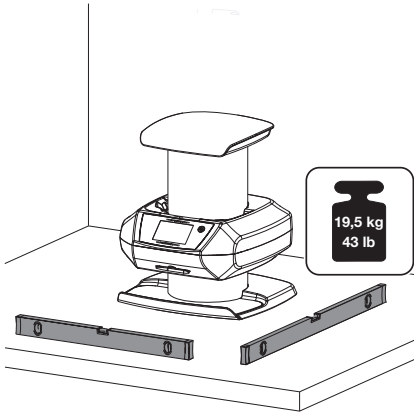

Fig. 3: ScanX Intraoral View

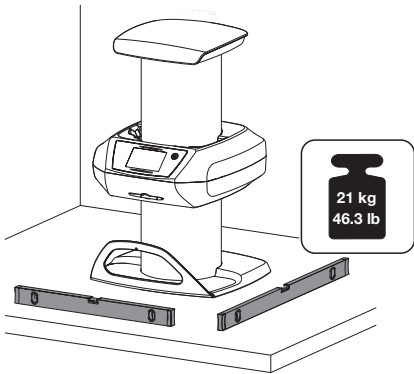
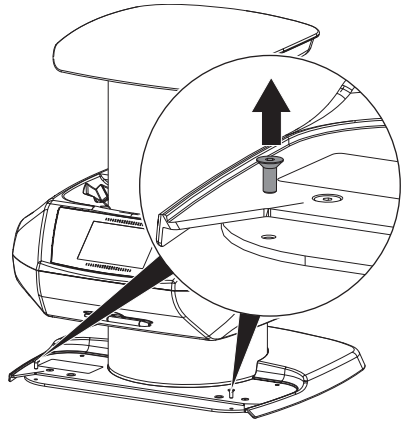

Fig. 4: ScanX Classic View

7.3 Assembling the support bracket

ScanX Intraoral View

1. Unscrew the screws from the base plate.



2. Place the support bracket on the base plate.

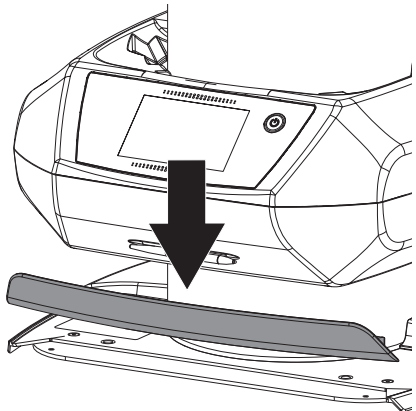

3. Attach the support bracket to the base plate using the screws.

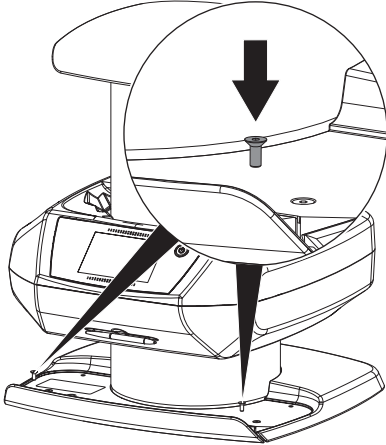

4. Place the tray liner in the appropriate recess.

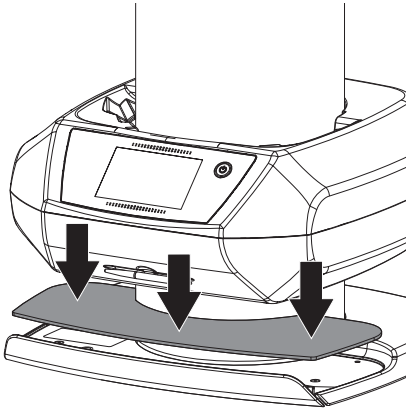

ScanX Classic View

1. Unscrew the screws from the base plate.

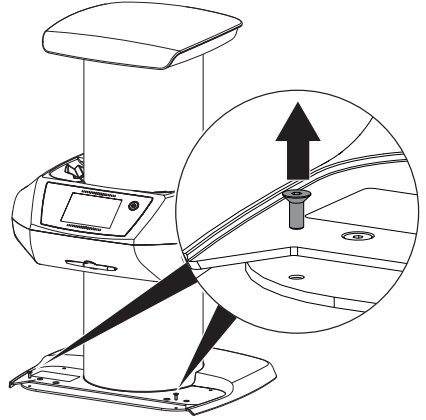

2. Place the connector bar on the base plate.

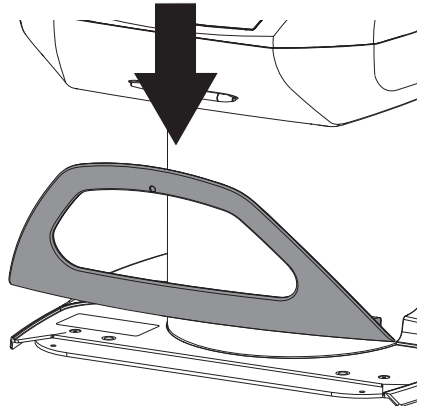

3. Attach the connector bar to the base plate using the screws.

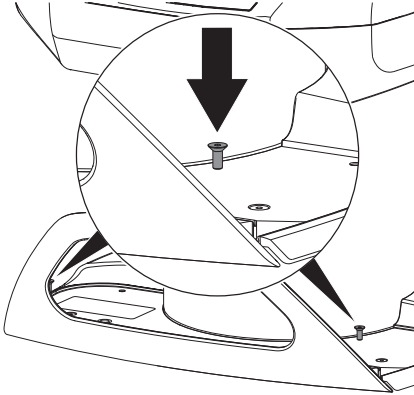

4. Place the collector mat in the appropriate recess.

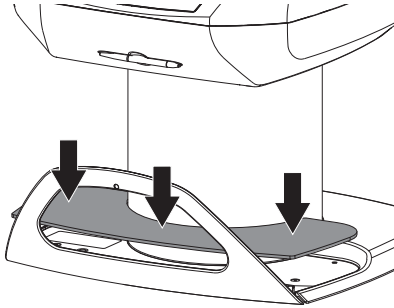

7.4 Removing the protective film from the touch screen

1. Remove one corner of the protective touch screen film and peel it off carefully.

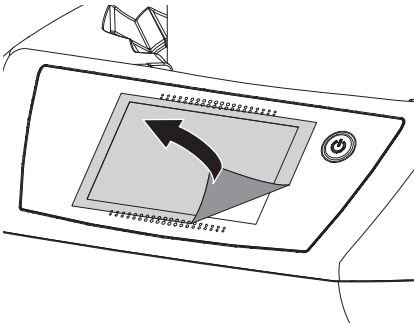

7.5 Attaching the Stylus

1. The Stylus is held on the unit by a magnet. Place the Stylus in the indentation provided.

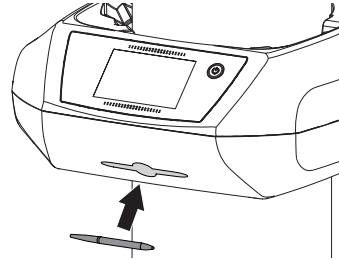

7.6 Checking the memory card



CAUTION

Loss of image data due to unexpected insertion or removal of the memory card

- › Insert or remove the memory card only when unit is switched off.

1. Checking proper insertion of the memory card in the unit. If the memory is inserted incorrectly in the device, take it out again and re-insert it properly.

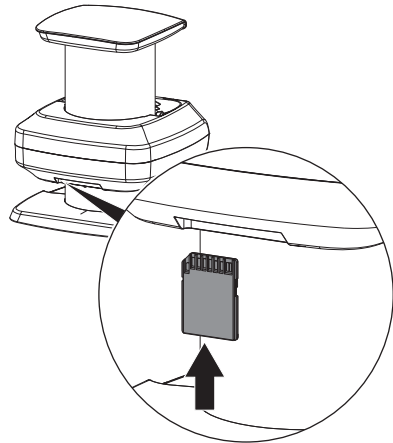

7.7 Electrical connection

Electrical safety when making connections

1. Connect the device to a correctly installed power outlet only.
2. Do not operate any other systems using the same multiple socket.
3. Make sure that none of the electrical cables leading to the unit are under any mechanical tension.
4. Before initial start-up verify that the mains supply voltage and the voltage stated on the type plate match (see also "4. Technical data").

Connecting the unit to the mains supply

 The unit has no main power switch. For this reason, it is important to set up the unit properly such that the plug can be easily accessed and unplugged if required.

Requirements:

- ✓ Properly installed power outlet close to the unit (observe the max. length of the power cord)
 - ✓ Easily accessible power outlet
 - ✓ Mains voltage matches the information shown on the type plate of the power supply unit
1. Plug the mains cable supplied with the unit into the power supply.
 2. Plug the connecting plug of the power supply unit into the connection socket of the unit.

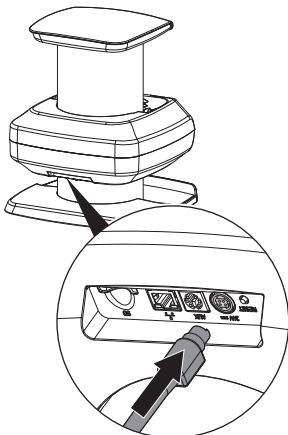

3. Plug the mains plug into the power outlet.

 The connection plug has a locking system. To unplug the unit, slide the housing of the connector backwards. Do not pull on the cable.

7.8 Connecting the unit to the network

Purpose of the network connection

The network connection is used to exchange information or control signals between the unit and a software installed on a computer, in order to, e. g.:

- Display parameters
- Select operating modes
- Indicate messages and error situations
- Change device settings
- Activate test functions
- Transmit data for archiving
- Provide documents concerning the devices

The unit can be connected to the network with a network cable or via WLAN.

 For information on connection via WLAN, see "Configuring WLAN on the unit".

Combining devices safely

- Safety and essential performance features are independent of the network. The device is designed appropriately for operation independent of a network. However, some of the functions are not available in this case.
- Faulty manual configuration can lead to significant network problems. The expert knowledge of a network administrator is required for configuration.
- The data connection utilizes part of the bandwidth of the network. Interactions with other medical devices cannot be completely excluded. Apply the IEC 80001-1 standard for risk assessment.
- The device is not suitable to be connected directly to the public internet.

Take care when connecting units together or to parts of other systems as there is always an element of risk (e.g. due to leakage currents).

- Only connect units when there can be no question of danger to operator or to patient.
 - Only connect units when it is safe to do so and when there is no risk of damage or harm to the surroundings.
 - If it is not 100% clear from the unit data sheet that such connections can be safely made or if you are in any doubt, always get a suitably qualified person (e.g. the manufacturer) to verify that the setup is safe.
1. Only connect peripheral units (e.g. computer, monitor, printer) that conform at least to the requirements set out in the standards IEC 60950-1 or EN 62368-1.

Connecting the unit via the network cable

1. Plug the enclosed network cable into the network socket of the device.

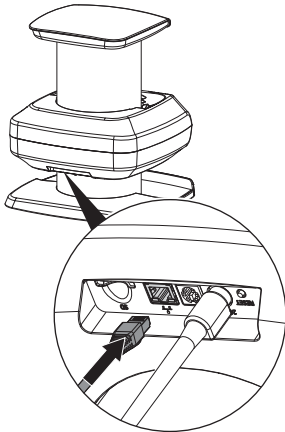

8 Commissioning and first start-up



NOTICE

Short circuit due to the build-up of condensation

- › Do not switch on the unit until it has warmed up to room temperature and is dry.

The unit supports the following imaging programs:

- VistaSoft distributed by Air Techniques
- Third-party software on request



Always use the current version of the imaging program in the commissioning of the device. Check the version of the enclosed imaging program versus the versions available at www.airtechniques.com.

8.1 Configuring the network

1. Switch on the network devices (router, PC, switch).
2. Check if TCP port 2006 and UDP port 514 are enabled in the firewall; enable them, if necessary.

If you are using the Windows firewall, you do not need to check the ports since you will be asked whether you want to enable them during the driver installation process.

Network configuration

Various options are available for network configuration:

- ✓ Automatic configuration via DHCP.
 - ✓ Automatic configuration via Auto-IP for direct connection of device and computer.
 - ✓ Manual configuration.
1. Configure the network settings of the device using the software or, if applicable, the touch screen.
 2. Check the firewall and release the ports, if applicable.

Network protocols and ports

Port	Purpose	Service
45123 UDP,	Device recognition and configuration	
45124 UDP		

Port	Purpose	Service
2006 TCP	Unit data	
514 ¹⁾ UDP	Event protocol data	Syslog
2005 TCP, 23 TCP	Diagnosis	Telnet, SSH
N/A	Check whether the device is turned on.	ICMP / Ping

- 1) The port can vary depending on the configuration.

Configuring WLAN on the unit

If the unit is to be operated via WLAN, the connection needs to be configured on the unit.



In order to establish a secure WLAN connection, we recommend encrypting the WLAN network with WPA2.

The quality and transmission range of the WLAN connection can be reduced by environmental conditions (e.g. thick walls, other WLAN devices). Mind the signal strength when you select a suitable location for set-up.

Requirements:

- ✓ You need to be logged-in on the unit as Administrator or Service Technician (**Settings > Access Levels > Administrator/Service Technician**).

1. Check the WLAN settings with your Network Administrator.
2. Tap the following on the touch screen: **Settings > System Settings > Network**.
3. Under **Interface**, select the **WLAN** option and confirm with **OK**.
4. Configure the WLAN.
5. Confirm with **OK**.



When the unit is first connected to a computer, it applies the language and time settings of the computer.

8.2 Configuring the unit in VistaSoft

Configuration is performed directly in VistaSoft.

1.  **Select the units.**

2. Mark the connected unit in the list.

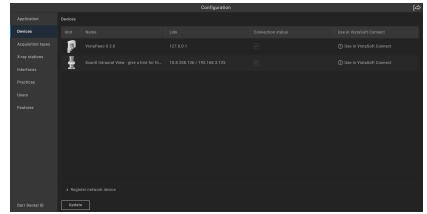

3. Click on **Edit connection settings**.
4. The unit name (designation) can be changed and information queried in **General**.
5. An IP address can be entered manually and DHCP can be activated / deactivated in **Connection**.
6. Extended functions e. g. IP address 2 can be set in **Extended**.

Entering a permanent IP address (recommended)



To reset the network settings, keep the unit reset key pressed for 15 - 20 seconds while switching on.

1. Deactivate DHCP in **Connection**.
2. Enter the IP address, subnet mask and gateway.
3. Click **Save values**.
The configuration is saved.

Testing the device

You can scan in an X-ray image to check that the unit is properly connected.

1. Open VistaSoft.
2. Create an X-ray station for the connected unit.
3. Log in the demo patient (patient ID: DEMO0001).
4. Select the acquisition type (e. g. Intraoral).
5. Scan a phosphor storage plate, see "11.3 Scanning the image data via a computer".

8.3 Prepare the X-ray cassette for an extraoral phosphor storage plate

The existing X-ray cassettes used with X-ray film can be retrofitted to enable the use of phosphor storage plates.

1. Remove the Intensifying screen(s) from the X-ray cassette.

8.4 X-ray unit settings

Intraoral X-ray units

The indicated standard values are a recommendation, the dentist determines the individual setting of the exposure values.



A setting of 60 kV is preferred provided it can be set on the X-ray unit.

The standard exposure values for F-speed film (e. g. Kodak Insight) can be used.

The following table shows the standard values for the exposure time and the dose area product of a PSP for an adult patient.

	DC emitter, 7 mA Tube length 20 cm					
	without X-ray field limitation		X-ray field limitation 0.8 x 1.2 in ² (20 x 30 mm ²)		X-ray field limitation 1.2 x 1.6 in ² (30 x 40 mm ²)	
	60 kV	mGycm ²	60 kV	mGycm ²	60 kV	mGycm ²
Incisor	0.08 s	14.6	0.08 s	3.1	0.08 s	6.2
Premolar	0.12 s	21.9	0.12 s	4.6	0.12 s	9.3
Molar	0.17 s	31.1	0.17 s	6.6	0.17 s	13.2
Bite wings	0.18 s	32.9	0.18 s	7.0	0.18 s	14

	DC emitter, 6 mA Tube length 30 cm					
	without X-ray field limitation		X-ray field limitation 0.8 x 1.2 in ² (20 x 30 mm ²)		X-ray field limitation 1.2 x 1.6 in ² (30 x 40 mm ²)	
	70 kV	mGycm ²	70 kV	mGycm ²	70 kV	mGycm ²
Incisor	0.13 s	11.8	0.13 s	2.5	0.13 s	5.0
Premolar	0.18 s	16.4	0.18 s	3.4	0.18 s	6.9
Molar	0.25 s	22.8	0.25 s	4.8	0.25 s	9.6
Bite wings	0.27 s	24.6	0.27 s	5.2	0.27 s	10.4

1. Check and adjust the specific X-ray unit in accordance with the standard values.

The following table shows the standard values for the exposure time and the dose area product of a PSP for a pediatric patient.



Children are more sensitive to radiation than adults. Keep the exposure parameters as low as possible taking into consideration the image quality. Refer also to the FDA information on pediatric X-ray imaging.

(refer to the FDA website on this topic, see <https://tinyurl.com/FDAPediatric>).

	DC emitter, 7 mA Tube length 20 cm					
	without X-ray field limitation		X-ray field limitation 0.8 x 1.2 in ² (20 x 30 mm ²)		X-ray field limitation 1.2 x 1.6 in ² (30 x 40 mm ²)	
	60 kV	mGycm ²	60 kV	mGycm ²	60 kV	mGycm ²
Incisor	0.05 s	9.1	0.05 s	1.9	0.05 s	3.8
Premolar	0.07 s	12.8	0.07 s	2.7	0.07 s	5.4
Molar	0.11 s	20.1	0.11 s	4.2	0.11 s	8.5
Bite wings	0.11 s	20.1	0.11 s	4.2	0.11 s	8.5

	DC emitter, 6 mA Tube length 30 cm					
	without X-ray field limitation		X-ray field limitation 0.8 x 1.2 in ² (20 x 30 mm ²)		X-ray field limitation 1.2 x 1.6 in ² (30 x 40 mm ²)	
	70 kV	mGycm ²	70 kV	mGycm ²	70 kV	mGycm ²
Incisor	0.08 s	7.3	0.08 s	1.5	0.08 s	3.1
Premolar	0.11 s	10.0	0.11 s	2.1	0.11 s	4.2
Molar	0.14 s	12.8	0.14 s	2.7	0.14 s	5.4
Bite wings	0.14 s	12.8	0.14 s	2.7	0.14 s	5.4

2. Check and adjust the specific X-ray unit in accordance with the standard values.

Extraoral X-ray units

Most extraoral X-ray units can be operated using the same settings as for analog films. The sensitivity of the image plate scanner has been optimized for class 200 film-foil system.

1. Set the X-ray unit to sensitivity class 200 (film-foil system).
2. If the X-ray unit does not use sensitivity class 200 (film-foil system), adapt the sensitivity of the image plate scanner using the HV-settings.
Consult with Air Techniques for the exact settings.
3. If deviations occur (see "14.1 Poor X-ray image"), adapt the image plate scanner to the X-ray unit (e. g. HV-setting, scanning mode).

8.5 Commissioning tests

The required tests (e.g. acceptance test) must be done in accordance with local rules and regulations.

1. Find out which tests are required.
2. Carry out testing in accordance with local rules and regulations.

Acceptance check



The 2D X-ray test phantom, and possibly the corresponding test phantom holder as well, is required for acceptance tests with the PSP and sensor as receivers.

1. Before commissioning the unit, the acceptance test of the X-ray system must be carried out in accordance with national regulations.
The constancy tests, which must be carried out at regular intervals by the surgery personnel, are based on the results of the acceptance test.

Electrical safety checks

1. Carry out the electrical safety check according to national law (e. g. in accordance with IEC 62353).
2. Document the results.
3. Carry out and document the instruction and handover for the unit.



A sample handover report is included in the attachment.

Usage

9 Operating the touch screen



NOTICE

Damage to the touch screen due to incorrect handling

- › Only operate the touch screen using your fingertips or the Stylus.
- › Do not use sharp objects (e.g. ball-point pen) to operate the touch screen.
- › Protect the touch screen from water.

1. Operate the touch screen by tapping it with a fingertip or the stylus to select a menu or input field.

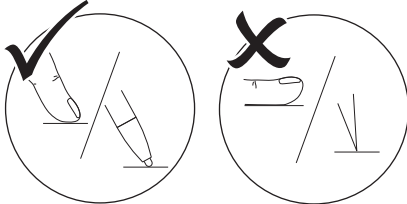

2. For further information about any window tap on the *Help* field.

9.1 Navigating

If the contents of the window cannot be completely displayed on the touch screen, a scroll bar appears.



1. Tap or to move the displayed section of the window.

9.2 Using menus

The menus integrated in a window contain additional commands that can be selected.

1. To open the menu, tap .

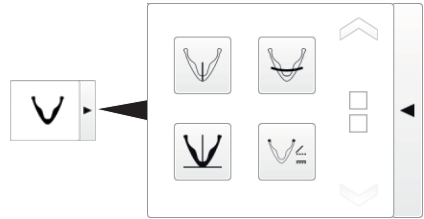

Fig. 5: Example: expanded menu

2. Select a command.

9.3 Entering text in a field

1. If a field requires input, tap in the field.

This opens the keyboard window.

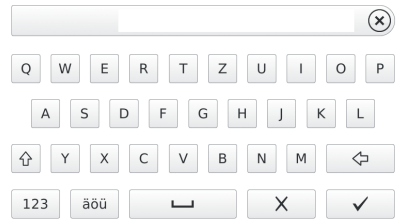





-	Switch to numbers/special characters
-	Shift key
-	Switch to German mutated vowels ("umlauts")
-	Delete
-	Cancel input and close keyboard
-	Confirm input and close keyboard
-	Spaces



9.4 Calling up messages on the touch screen

The  view on the touchscreen displays the current messages.

The *Messages* view at *Settings > Service menu > Messages* displays the history of all messages. A switch to the *Access level Technician* is required.

Messages are divided into the following categories:

	Fault	Unit will no longer function. When the error has been remedied, it may be necessary to acknowledge the error message.
	Notice	After acknowledgment the unit will continue to work, but only with limited functions.
	Note	Important information for the operator, e.g. about the current status of the device. The unit continues to operate.
	Information	Information for the operator. The unit continues to operate.
	Fault-free operation	

1. Tap .
This displays the message. If there are several messages, the most current with the highest priority is displayed first.
2. For more information about the message, tap .

10 Correct use of phosphor storage plates



WARNING

Risk of cross contamination when not using the barrier envelope or when using the barrier envelope more than once

- › Do not use an phosphor storage plate without a barrier envelope.
- › Do not re-use the barrier envelope (disposable item).



CAUTION

Image data on the phosphor storage plate is not permanent

- The image data is altered by light, natural X-ray radiation and scattered X-ray radiation. This will lead to a reduction in diagnostic information and clarity.
- › Read the image data within 30 minutes of exposure.
 - › Never handle exposed phosphor storage plates without the barrier envelope.
 - › Do not subject an exposed phosphor storage plate to X-ray radiation before and during the scanning process. Do not X-ray during the scanning process if the unit is in the same room as the X-ray tube.
 - › Phosphor storage plates must only be read using a phosphor storage plate scanner that is approved by Air Techniques.



CAUTION

Phosphor storage plates (PSP) are toxic

PSPs that are not used with a barrier envelope can lead to poisoning when placed in the mouth or swallowed.

- › Only place PSPs in the patient's mouth in a barrier envelope.
- › Do not swallow the PSP or parts of it.
- › If the PSP or parts of it have been swallowed, consult a specialist doctor immediately and remove the PSP.
- › If the barrier envelope was damaged in the patient's mouth, rinse the mouth thoroughly with copious amounts of water. Do not swallow the water in the process.

1. Phosphor storage plates are flexible like X-ray film. However, the phosphor storage plates should not be kinked.

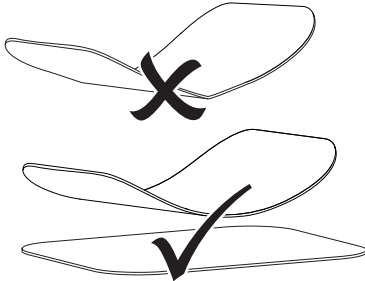

2. Do not scratch the phosphor storage plates. Do not subject the phosphor storage plates to pressure from hard or pointed objects.

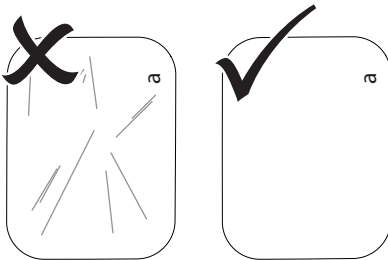

3. Do not soil the phosphor storage plates.

4. Protect the phosphor storage plates from sunlight and ultraviolet light. Store phosphor storage plates in a barrier envelope or intraoral/extraoral plate protector of proper size.
5. Phosphor storage plates will be pre-exposed on exposure to natural radiation and stray x-ray radiation. Protect erased or exposed phosphor storage plates from X-ray beams. If the phosphor storage plate has been stored for longer than one week, erase the phosphor storage plate prior to use.
6. Do not store phosphor storage plates under hot or moist conditions. Note the ambient conditions (see "4 Technical data").
7. When used properly, phosphor storage plates can be exposed, read and erased several hundred times provided there is no mechanical damage. Replace the phosphor storage plate if there are any signs of damage, e.g. protective layer is damaged or visible scratches, that could interfere with the diagnosis.
8. Phosphor storage plates that have a production or packaging defect will be replaced by Air Techniques in the same quantity.
9. Clean phosphor storage plates properly (see "12 Cleaning and disinfection").

11 Operation



CAUTION

Image data on the phosphor storage plate is not permanent

The image data is altered by light, natural X-ray radiation and scattered X-ray radiation. This will lead to a reduction in diagnostic information and clarity.

- › Read the image data within 30 minutes of exposure.
- › Never handle exposed phosphor storage plates without the barrier envelope.
- › Do not subject an exposed phosphor storage plate to X-ray radiation before and during the scanning process. Do not X-ray during the scanning process if the unit is in the same room as the X-ray tube.
- › Phosphor storage plates must only be read using a phosphor storage plate scanner that is approved by Air Techniques.

11.1 Replacing the plate guide

The unit can scan phosphor storage plates of size 0 to size 4 with the corresponding plate guide. The matching plate guide is needed for each size of phosphor storage plate. The size of the phosphor storage plate is marked on the plate guide. Any of the feed slits can be used for this purpose.

All plate guides need to be removed during the scanning of phosphor storage plates.

1. Check and make sure that the proper plate guide is inserted.
If the incorrect plate guide has been inserted, it must be removed and the correct plate guide must be inserted.

2. Remove the plate guide.

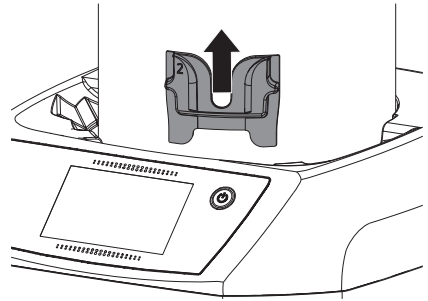

3. Snap-in the plate guide, matching the size of the phosphor storage plate, using a free feed slit on the transport arch.

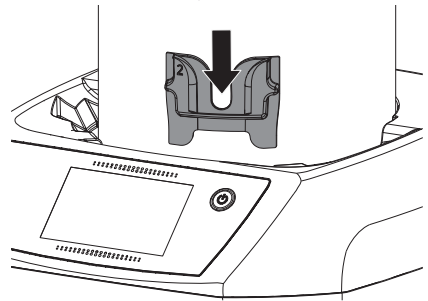

11.2 X-ray

Intraoral X-ray



The procedure is described using a size 2 phosphor storage plate as an example.

Required accessories:

- PSP
- Barrier envelope of the same size as the PSP
- Plate guide matching the size of the phosphor storage plate



WARNING

Risk of cross contamination when not using the barrier envelope or when using the barrier envelope more than once

- › Do not use an phosphor storage plate without a barrier envelope.
- › Do not re-use the barrier envelope (disposable item).



WARNING

Danger from the re-use of products intended for single use

Single-use article is damaged after use and cannot be reused.

- › Dispose of single-use articles after use.

Preparing the X-ray

- ✓ The PSP has been cleaned.
 - ✓ The PSP is not damaged.
 - ✓ The marker (if present) sticks to the correct position on the image plate. If the marker peels off, replace the image plate.
1. If using it for the first time or if it has been stored for over a week: erase the PSP (see "11.5 Erasing the phosphor storage plate").
 2. Completely slide the PSP into the barrier envelope. The black (inactive) side of the PSP must be visible.

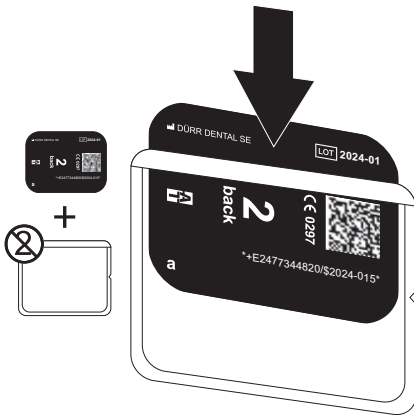

3. Pull off the adhesive strip and close the barrier envelope tightly by pressing together firmly.

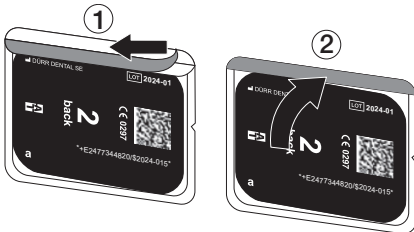

Taking the X-ray image



NOTICE

Damage to the phosphor storage plate (PSP) caused by a sharp-edged holding system

- › Only use holding systems that do not damage the barrier envelope or the PSP.
- › Do not use holding systems with sharp edges.



Wear hand protection.

1. Place the PSP in the barrier envelope into the patient's mouth. Doing this, make sure that the active side of the PSP faces the X-ray tube.

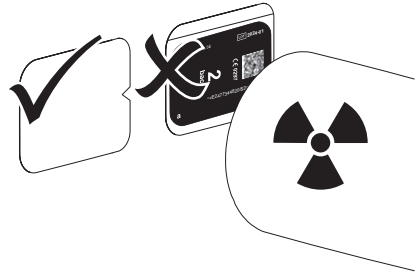

2. Set the exposure time and setting values on the X-ray unit (see "8.4 X-ray unit settings").
3. Record the X-ray image.

Result:

The image data must be scanned within 30 minutes.

Preparing for scanning



CAUTION

Light erases the image data on the phosphor storage plate

- › Never handle exposed phosphor storage plates without either a barrier envelope or an intraoral/extraoral plate protector.



Wear hand protection.

1. Remove the PSP with the barrier envelope from the patient's mouth.

**WARNING****Contamination of the unit**

- › Clean and disinfect the barrier envelope before removing the PSP.

2. In the event of heavy soiling, e. g. from blood, dry clean the barrier envelope and protective gloves, e. g. wipe with a clean cellulose cloth.
3. Disinfect the barrier envelope and protective gloves with a disinfectant wipe. Alternatively, use a spray disinfectant on a soft, lint-free cloth.

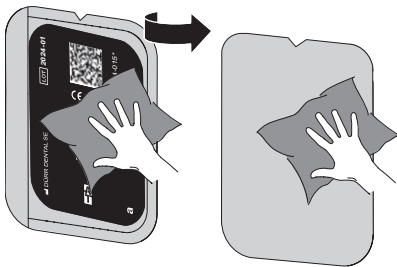

4. Allow the barrier envelope to fully dry.
5. Pull off the protective gloves, disinfect and clean the hands.

**NOTICE****Powder from the protective gloves on the PSP damages the unit during scanning**

- › Completely clean all traces of the protective glove powder from your hands before handling the PSP.
6. Tear the barrier envelope and place the phosphor storage plate in the transfer box. If the active side of the phosphor storage plate is facing up, turn the phosphor storage plate over immediately.

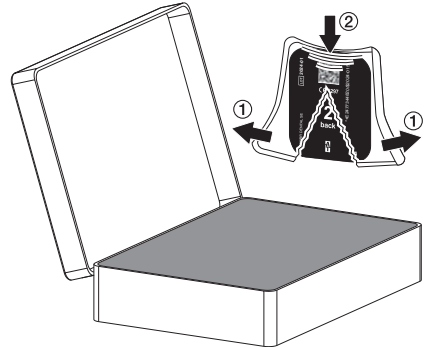

Extraoral X-ray

 The procedure is described using a PSP Plus for Pano as an example.

Required accessories:

- PSP
- Plate protector matching the size of the phosphor storage plate
- X-ray cassette without intensifying screen, (see "3.3 Optional items" or "8.3 Prepare the X-ray cassette for an extraoral phosphor storage plate")

Preparing the X-ray

- ✓ The PSP has been cleaned.
 - ✓ The PSP is not damaged.
1. If using it for the first time or if it has been stored for over a week: erase the PSP (see "11.5 Erasing the phosphor storage plate").
 2. Slide the phosphor storage plate fully into the plate protector. The black (inactive) side of the PSP must be visible.

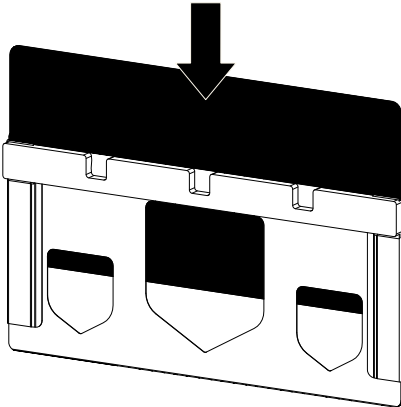

3. Place the plate protector into the X-ray cassette. The foam side of the plate guide must face in the direction of the cover of the X-ray cassette.

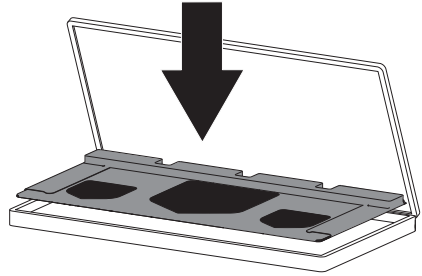

Taking the X-ray image

1. Insert the X-ray cassette into the X-ray unit. Make sure that the active side of the phosphor storage plate faces the X-ray tube.
2. Set the exposure time and setting values on the X-ray unit (see "8.4 X-ray unit settings").
3. Record the X-ray image.
The image data must be scanned within 30 minutes.

11.3 Scanning the image data via a computer

Starting the phosphor storage plate scanner and software

 The scanning process is described for the VistaSoft imaging software.

For further information regarding the use of the imaging software, refer to the relevant manual.

1. Start VistaSoft.
2. Select the patient.
3. Select the corresponding image type in the menu bar.
4. Select the unit.
5. Set the acquisition mode.
Recording starts immediately.
6. If ScanManager is enabled, select the X-ray job on the touch screen of the unit.

Result:

The touch screen will display an animated visual symbol requesting insertion of the phosphor storage plate.

 Insert the phosphor storage plate only once the bar above the animation is green.

Do not insert another phosphor storage plate as long as the bar of the animation is blue.

Scanning an intraoral phosphor storage plate



CAUTION

Loss of image data caused by stray ambient light entering the unit

- › Remove the plate guide only after the phosphor storage plate has dropped into the collecting tray.

1. Slide the phosphor storage plate into an unoccupied plate guide until the PSP is automatically drawn in.
The size of the plate guide must match the size of the PSP (see "11.1 Replacing the plate guide").
The inactive side of the PSP must be visible.

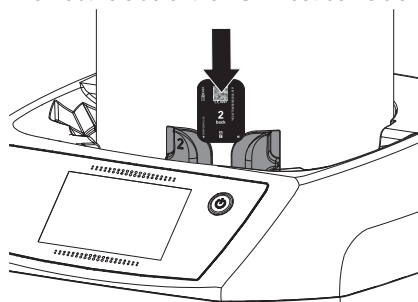

Scanning progress is displayed on the touch screen. Image data is saved automatically.



The touch screen only shows a preview as an initial impression of the X-ray image. Limitations to image previews occur due to image size and/or exposure conditions. For purposes of diagnosis, the X-ray image must be viewed on a diagnostic monitor.

After reading, the phosphor storage plate is erased and drops into the collecting tray.

2. Save the X-ray image.
3. Remove the phosphor storage plate and prepare to take a new X-ray.
4. Remove the plate guide after the entry slot status LED on the touch screen switches to green.

Reading the extraoral image plate

i In order not to mix up X-ray images, only scan the X-ray images from the selected patient.

1. Remove the plate protector from the X-ray cassette.
2. Place the plate protector with the phosphor storage plate in the entry slot of the transport arch.

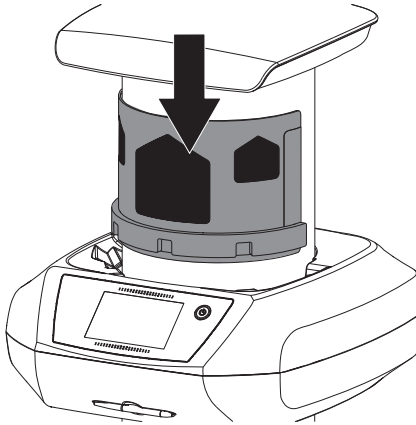

CAUTION
Loss of image data caused by stray ambient light entering the unit
 > Remove the intraoral/extraoral plate protector only after the phosphor storage plate has dropped into the collecting tray.

3. Place a finger on the printed surface of the phosphor storage plate and push downwards until the phosphor storage plate is drawn in automatically.

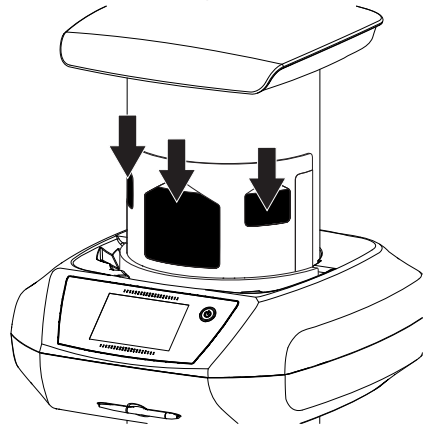

Scanning progress is displayed on the touch screen. Image data is saved automatically.

i The touch screen only shows a preview as an initial impression of the X-ray image. Limitations to image previews occur due to image size and/or exposure conditions. For purposes of diagnosis, the X-ray image must be viewed on a diagnostic monitor.

After it has been scanned, the phosphor storage plate is erased and drops into the collecting tray.

4. Save the X-ray image.
5. Remove the PSP and prepare it for recording another X-ray image.
6. Remove the plate protector.

11.4 Scanning image data via the touch screen on the unit

Starting the phosphor storage plate scanner

No PC connection is needed for scanning the image data via the touch screen. The image data is stored locally on the memory card. In order to transfer the image data to the imaging software, the unit must be connected to a computer. There are two options for scanning via the touch screen:



Scan:

Before scanning the image data, the patient data and exposure settings of the image are acquired and then saved with the image data.

If no patient data and exposure settings of the image are entered, the image is saved to a folder with date and time.



Quick scan:

The image data is saved to a folder with the date and time and no additional information.



Use **Help** on the touch screen for further information on operating the unit via the touch screen.

Prerequisites:

✓ Memory card (SDHC, max. 32 GB) is inserted in the slot of the unit.

1. Press  to switch the unit on.

Start scanning:

1. On the touch screen, tap on **Scan**.
2. Enter the patient data.

3. Select the image settings and scanning mode.

An animation on the touch screen prompts for insertion of the imaging plate.



Insert the imaging plate only once the bar above the animation is green.



Fig. 6: Example of the animation prompting for insertion of the imaging plate

Start quick scan:

1. On the touch screen, tap on **Quick scan**.
2. Select the scanning mode.

An animation on the touch screen prompts for insertion of the imaging plate.



Insert the imaging plate only once the bar above the animation is green.



Fig. 7: Example of the animation prompting for insertion of the imaging plate

Scanning an intraoral phosphor storage plate



CAUTION

Loss of image data caused by stray ambient light entering the unit

- Remove the plate guide only after the phosphor storage plate has dropped into the collecting tray.

1. Slide the phosphor storage plate into an unoccupied plate guide until the PSP is automatically drawn in.
The size of the plate guide must match the size of the PSP (see "11.1 Replacing the plate guide").
The inactive side of the PSP must be visible.

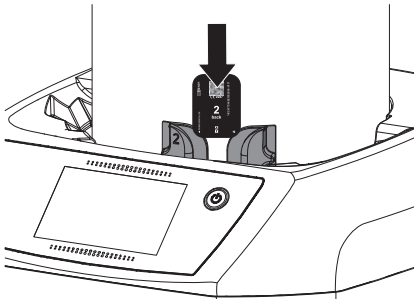

Scanning progress is displayed on the touch screen. Image data is saved automatically.



The touch screen only shows a preview as an initial impression of the X-ray image. Limitations to image previews occur due to image size and/or exposure conditions. For purposes of diagnosis, the X-ray image must be viewed on a diagnostic monitor.

After reading, the phosphor storage plate is erased and drops into the collecting tray.

2. Save the X-ray image.
3. Remove the phosphor storage plate and prepare to take a new X-ray.
4. Remove the plate guide after the entry slot status LED on the touch screen switches to green.

Reading the extraoral image plate



In order not to mix up X-ray images, only scan the X-ray images from the selected patient.

1. Remove the plate protector from the X-ray cassette.
2. Place the plate protector with the phosphor storage plate in the entry slot of the transport arch.

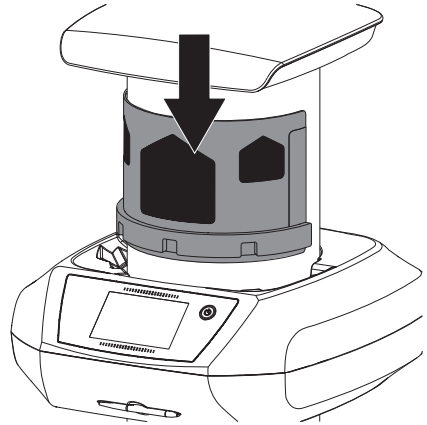

**CAUTION****Loss of image data caused by stray ambient light entering the unit**

- Remove the intraoral/extraoral plate protector only after the phosphor storage plate has dropped into the collecting tray.

3. Place a finger on the printed surface of the phosphor storage plate and push downwards until the phosphor storage plate is drawn in automatically.

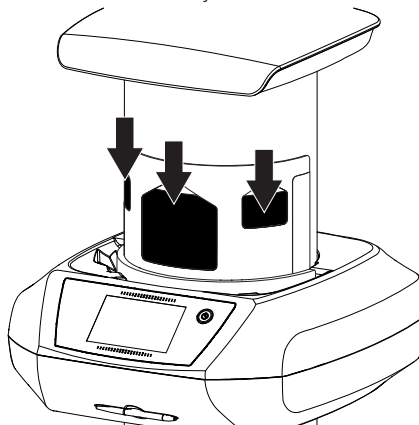

Scanning progress is displayed on the touch screen. Image data is saved automatically.



The touch screen only shows a preview as an initial impression of the X-ray image. Limitations to image previews occur due to image size and/or exposure conditions. For purposes of diagnosis, the X-ray image must be viewed on a diagnostic monitor.

After it has been scanned, the phosphor storage plate is erased and drops into the collecting tray.

4. Save the X-ray image.
5. Remove the PSP and prepare it for recording another X-ray image.
6. Remove the plate protector.

Transmitting image data to the computer

X-ray images created using the touch screen of the device are saved to a memory card. These X-

ray images can be imported into an imaging software via a network connection.

1. Connect the unit to the network.
2. Start the imaging software.
3. Start the image import via the imaging software (further information can be found in the manual of the imaging software).
4. Save the image data.

The image data on the memory card is erased automatically as soon as the transfer has been successfully completed.

11.5 Erasing the phosphor storage plate

The image data is erased automatically after scanning.

If you do not want the image data to be erased, this function can be disabled for the current scanning process by selecting *Disable erasing light* on the touch screen of the unit.

The special **ERASE** mode only activates the erasure unit of the imaging plate scanner. No image data is scanned.

The PSP needs to be erased using the special mode in the following cases:

- The first time the PSP is used, or if it is stored for more than one week.
- Due to an error, the image data on the PSP has not been erased (software error message).

Erasing the PSP via a computer

1. Select the special **ERASE** mode in the software.
2. Scan the PSP (see "11.3 Scanning the image data via a computer").

Erasing the PSP via the touch screen

1. On the touch screen, tap on *Quick scan*.
2. Select the scanning mode **ERASE**.
3. Scan the PSP (see "11.4 Scanning image data via the touch screen on the unit").

11.6 Switching the unit off

1. Press the on/off switch  for 3 seconds.

As soon as the unit has shut down it switches off completely. The touch screen is off.



After you switch off the unit, wait 10 s before switching the unit on again.

12 Cleaning and disinfection

Unless specified otherwise, Air Techniques recommends Monarch disinfectant wipes for cleaning and disinfection of the unit and accessories. For a full list of approved cleaning agents, please contact Air Techniques.

Do not use the following disinfectant wipes:

- CaviWipes 1
- Discide Ultra



NOTICE

The use of unsuitable agents and methods can damage the unit and accessories

- › Only use the disinfection and cleaning agents specified or approved by Air Techniques and the EPA.
- › Comply with the operating instructions of the disinfectants and cleaning agents.



Wear hand protection.

12.1 Phosphor storage plate scanner

Surface of the unit

The surface of the unit must be cleaned and disinfected if it is contaminated or soiled.



NOTICE

Liquid can cause damage to the unit

- › Do not spray the unit with cleaning agents or disinfectants.
- › Make sure that no liquid penetrates into the unit.

1. Remove any soiling with a soft, lint-free cloth that has been dampened with cold tap water.
2. Disinfect the surfaces with a disinfectant wipe. Alternatively, use a spray disinfectant on a soft, lint-free cloth. Comply with the operating instructions of the disinfectant.

12.2 Plate guide

The plate guides can be cleaned and disinfected with a wipe disinfection.



NOTICE

Heat damages the plate guide

- › Do not subject plate guide to steam sterilization.

1. Remove any soiling from both sides of the plate guide with a soft, damp, lint-free cloth.
2. Disinfect the plate guide using a disinfectant wipe. Alternatively, use a spray disinfectant on a soft, lint-free cloth. Comply with the operating instructions of the disinfectant.
3. Allow the plate guide to completely dry before using it.

12.3 Barrier envelope

1. Clean the Barrier Envelope after being removed from the patient's mouth with a disinfectant wipe, such as Air Techniques Monarch Surface Wipes.
2. Allow the Barrier Envelope to completely dry prior to ejecting the PSP.

12.4 Phosphor storage plate

Cleaning and disinfectant wipes are unsuitable for the cleaning of phosphor storage plates and may damage them.

Only use a cleaning agent that is compatible with the materials:

Air Techniques recommends the PSP Cleaning Wipes (see "3.4 Consumables"). Only this product has been subjected to material compatibility testing by the manufacturer.



NOTICE

Heat or humidity damage the phosphor storage plate

- › Do not sterilize the phosphor storage plate with steam.
- › Do not disinfect the phosphor storage plate by immersion.
- › Only use cleaning agents that are compatible with the materials.

1. Soiling on both sides of the phosphor storage plate should be cleaned off with a soft, lint-free cloth before each use.
2. Remove persistent or dried soiling with the phosphor storage plate cleaning cloth. Comply with the instructions for use of the cleaning cloth.
3. Allow the phosphor storage plate to completely dry before using it.

12.5 Plate protector

The extraoral plate protector can be cleaned and disinfected in the event of contamination or visible soiling.

Air Techniques recommends Monarch Surface Wipes.

1. Remove any soiling with a soft, lint-free cloth that has been dampened with cold tap water.

2. Disinfect the surface with a disinfectant wipe. Alternatively, use disinfectant on a soft, lint-free cloth.

12.6 Stylus

The Stylus can be cleaned in the same way as the unit (see "12.1 Phosphor storage plate scanner").

13 Maintenance

13.1 Recommended maintenance schedule



Do not attempt to carry out any maintenance work.

The internal components of the unit are accessible only after parts are removed with special tools and may be opened and subjected to maintenance by authorized service technicians of dealers only.

Contact your local authorized Air Techniques dealer for any maintenance. Non-compliance with these instructions can lead to equipment damage and loss of the warranty.



Prior to working on the unit or in case of danger, disconnect it from the mains.

Maintenance interval	Maintenance work
Annually	› Visually inspect the device.
	› Check the phosphor storage plates and intraoral/extraoral plate protectors for scratches, and replace them if necessary.
	› Check the light protection brushes, cut any protruding hairs and remove them.
	› Check the belt drives, transport belts and springs, and replace if necessary.
	› Disassemble the transport arch.
	› Remove dust and dirt from accessible parts.
Every 2 years	› Mount the transport arch.
	› Carry out a system check.
	› Replace the pressure roller unit.
	› Replace the transport belts and tension springs.
	› Replace the timing belt.

13.2 Check image quality

To assure the image quality, the unit must be subjected to maintenance (see "13.1 Recommended maintenance schedule") and regular cleaning and disinfection (see "12 Cleaning and disinfection") and the image quality of the PSP and X-ray system need to be checked.

Inspection interval	Work
Daily / before each use	› Clean the PSP, if necessary.
	› Check the PSP for scratches. If there are scratches on the surface, take a homogeneous test image (see "Check the PSP with a homogeneous test image"), replace the PSP, if applicable.
	› Keep an eye on the image quality with each X-ray image taken, also refer to "14.1 Poor X-ray image".
Monthly	› Take a homogeneous test image of the PSP (refer to "Check the PSP with a homogeneous test image"). If scratches or artifacts are visible in the image that may possibly have an adverse effect on the diagnostics, replace the PSP.

Inspection interval	Work
----------------------------	-------------

Every 3 months	<ul style="list-style-type: none">› Check X-ray system.› Take an X-ray image with a 2D X-ray test phantom. Check the image for homogeneity, resolution, contrast and artifacts, refer to "Check X-ray system".
----------------	---

Check the PSP with a homogeneous test image

Scratches on the surface of the PSP may be visible in the X-ray image and may impair the ability to diagnose the X-ray images. If scratches are visible in the image that may impair the diagnostics, the PSP must be discarded.

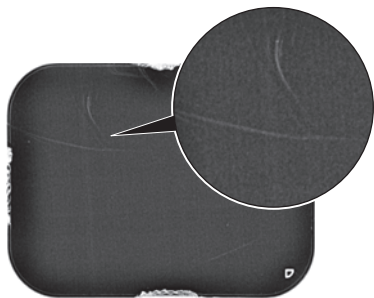

Fig. 8: PSP with scratches

1. Place the PSP on a level surface at a distance of approximately 30 cm from the X-ray tube. Doing this, make sure that the active side of the PSP faces the X-ray tube.
2. Set the exposure time and setting values on the X-ray unit for a molar x-ray image (see "8.4 X-ray unit settings").
3. Scan the PSP with the PSP scanner at high resolution.
4. Check the image for homogeneity.
No scratches visible in the image: PSP can still be used.
Scratch is visible in the image: discard the PSP.

Check X-ray system

To check the X-ray system, take an X-ray image with the test phantom (refer to "3.3 Optional items"). This can be used to check the image produced with the X-ray system for homogeneity, resolution, contrast and artifacts.

1. Take an X-ray image with the test phantom. Comply with the instructions for use of the test phantom.
2. Read the PSP.
3. Check the image for homogeneity, resolution, contrast and artifacts.
4. If errors are visible in the image, contact a service technician.

? Troubleshooting

14 Tips for operators and service technicians





Any repairs above and beyond routine maintenance may only be done by suitably qualified personnel or by one of our service technicians.



Prior to working on the unit or in case of danger, disconnect it from the mains.

14.1 Poor X-ray image

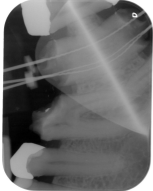
Error	Possible cause	Remedy
X-ray image does not appear on the monitor after scanning	PSP inserted improperly and inactive side was scanned	› Scan the PSP again immediately, making sure you feed it in correctly in the process.
	Image data on the PSP has been erased, e.g. by ambient light	› Always scan the image data of the PSP as soon as possible.
	Fault in the unit	› Contact technician.
	No image data on PSP, PSP not exposed	› Expose the PSP.
	X-ray unit is faulty	› Contact technician.
X-ray image too dark	X-ray dose too high	› Check X-ray parameters.
	Incorrect brightness/contrast settings in the software	› Adjust the brightness of the X-ray image in the software.
X-ray image too bright	Exposed PSP has been exposed to ambient light	› Always scan the image data of the PSP as soon as possible.
	X-ray dose too low	› Check X-ray parameters.
	Incorrect brightness/contrast settings in the software	› Adjust the brightness of the X-ray image in the software.
X-ray image only shadowy	The X-ray dose on the PSP was insufficient	› Increase X-ray dose.
	Amplification (HV value) is set too low in the software	› Increase amplification (HV value).
	Unsuitable scanning mode selected	› Select a suitable scanning mode.
	The setting for the threshold value is too high	› Reduce the threshold value.
X-ray image is mirror-inverted	Phosphor storage plate incorrectly inserted in intraoral/extraoral plate protector or barrier envelope.	› Insert phosphor storage plate correctly.
	Phosphor storage plate not placed straight.	› Position the PSP correctly.

Error	Possible cause	Remedy
<p>Ghosting or double exposure on X-ray image</p> 	<p>PSP exposed twice PSP not sufficiently erased</p>	<ul style="list-style-type: none"> › Only expose the PSP once. › Check the erasure unit for proper function. › Inform a service technician, if the problem persists.
<p>X-ray image mirrored in one corner</p> 	<p>PSP creased during X-ray exposure</p>	<ul style="list-style-type: none"> › Do not bend the PSP.
<p>Shadow on the X-ray image</p> 	<p>PSP removed from the barrier envelope before scanning</p>	<ul style="list-style-type: none"> › Do not handle PSPs without a barrier envelope. › Store the PSP in a barrier envelope.
<p>X-ray image cut off, part missing</p> 	<p>A metal part of the X-ray tube is in front of the X-ray beam</p> <p>Faulty edge masking in imaging software</p>	<ul style="list-style-type: none"> › Recording an X-ray image, make sure there are no metal parts between the X-ray tube and the patient. › Check X-ray tube. › Deactivate edge masking.
<p>Software unable to combine the data to make a complete image</p>	<p>The X-ray dose on the PSP was insufficient</p> <p>Amplification (HV value) is set too low in the software</p> <p>Unsuitable scanning mode selected</p> <p>The setting for the threshold value is too high</p>	<ul style="list-style-type: none"> › Increase X-ray dose. › Increase amplification (HV value). › Select a suitable scanning mode. › Reduce the threshold value.

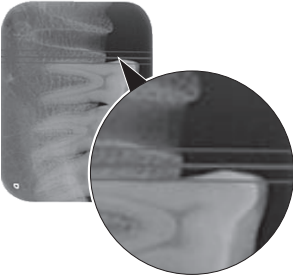
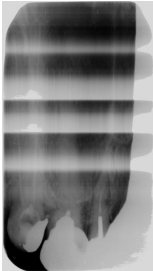
Error	Possible cause	Remedy
<p>X-ray image has strips on image</p>	<p>PSP has been pre-exposed, e.g. by natural radiation or stray X-ray radiation</p> <hr/> <p>Parts of PSP exposed to light during handling</p> <hr/> <p>PSP dirty or scratched</p>	<p>› If the PSP has been stored for more than one week, erase the PSP prior to use.</p> <hr/> <p>› Do not expose exposed PSPs to bright light.</p> <p>› Scan image data within half an hour after the exposure.</p> <hr/> <p>› Clean the PSP.</p> <p>› Replace scratched PSP.</p>
<p>Bright stripes in the scanning window</p>	<p>Too much incident ambient light during the scanning process</p>	<p>› Darken the room.</p> <p>› Turn the unit such that no light is directly incident on the input unit.</p>
<p>Horizontal, grey lines in the X-ray image, extending beyond the left and right image edge</p> 	<p>Transport slipping</p>	<p>› Clean the transport mechanism, replace the transport belts if necessary.</p>
<p>X-ray image is stretched lengthwise with bright, horizontal stripes</p> 	<p>Wrong barrier envelope or PSP used</p>	<p>› Only use original accessories.</p>

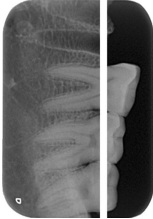
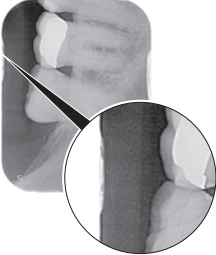
Error	Possible cause	Remedy
<p>X-ray image split vertically into two halves</p> 	<p>Dirt in the laser slit (e.g. hair, dust)</p>	<ul style="list-style-type: none"> ➤ Clean the laser slit.
<p>X-ray image with small bright spots or clouding</p>	<p>Micro scratches on the PSP</p>	<ul style="list-style-type: none"> ➤ Replace the PSP.
<p>Lamination of the PSP detaches at the edge</p> 	<p>Wrong retainer system used</p> <p>PSP handled incorrectly.</p>	<ul style="list-style-type: none"> ➤ Only use original PSP and film retainer systems. ➤ Use the PSP correctly. ➤ Comply with the operating instructions of the PSP and film retainer systems.

14.2 Software error

Error	Possible cause	Remedy
<p>"Too much ambient light"</p>	<p>Unit is exposed to too much light</p>	<ul style="list-style-type: none"> ➤ Darken the room. ➤ Turn the unit such that no light can directly enter into the entry slot.
<p>"Overtemperature"</p>	<p>Laser or erasure unit too hot</p>	<ul style="list-style-type: none"> ➤ Switch the unit off and allow it to cool.
<p>"Erasure unit fault"</p>	<p>LED defective</p>	<ul style="list-style-type: none"> ➤ Contact technician.

Error	Possible cause	Remedy
Imaging software fails to recognize the unit	Unit not switched on	› Switch the device on.
	Connecting cable between unit and computer not correctly connected	› Check the connecting cable.
	Computer does not detect any connection to the unit	› Check the connecting cable. › Check the network settings (IP address and subnet mask).
	Hardware error	› Contact technician.
	The IP address of the unit is being used by another unit	› Check the network settings (IP address and subnet mask) and assign a unique IP address to each unit. › Inform a service technician, if the problem persists.
The unit does not appear in the selection list in VistaConfig	Unit is connected downstream of a router	› Configure the IP address without an intermediate router on the unit. › Reconnect the router. › Manually enter the IP address in VistaConfig and register the unit.
	The IP address of the unit is being used by another unit	› Check the network settings (IP address and subnet mask) and assign a unique IP address to each unit. › Inform a service technician, if the problem persists.
The unit appears in the Vista-Config selection list, but connection is not possible	Subnet masks of the computer and the unit do not match	› Check subnet masks, adjust if necessary.
Error message "E2490"	The connection to the unit was interrupted while the software was still attempting to communicate with the unit	› Restore the connection to the unit. › Repeat the process.
Error during data transmission between unit and computer. Error message "CRC error timeout"	Connecting cable used is incorrect or too long	› Only use original cables.

14.3 Fault on the unit

Error	Possible cause	Remedy
Unit does not switch on	No mains voltage	<ul style="list-style-type: none"> › Check the mains cable and plug connection and replace if necessary. › Check the power supply unit. › If the touch screen does not light up, replace the power supply. › Check the mains fuse in the building.
	On/off switch is defective	<ul style="list-style-type: none"> › Contact technician.
	Unit switches off again after a short time	<ul style="list-style-type: none"> Mains cable or power supply unit plug not inserted correctly Hardware defect Mains supply voltage too low
Loud operating noises after switching on lasting for more than 30 seconds	Radiation deflector defective	<ul style="list-style-type: none"> › Contact technician.
Unit not responding	The unit has not yet completed the startup procedure	<ul style="list-style-type: none"> › After switching the unit on, wait 20 - 30 seconds for the startup procedure to be completed.
	Unit is blocked by the firewall	<ul style="list-style-type: none"> › Enable the ports for the unit in the firewall settings.
Unit is on, but there is no display on the touch screen	Touch screen initialization fault	<ul style="list-style-type: none"> › Switch the unit off and on again.
	Touch screen brightness set too dark	<ul style="list-style-type: none"> › Update firmware. › Increase the brightness of the touch screen.
	Touch screen defective	<ul style="list-style-type: none"> › Contact technician.

14.4 Error messages on the touch screen

Error	Possible cause	Remedy
Error code -1008	Internal connection disrupted	<ul style="list-style-type: none"> › Update firmware.
Error code 1010	Temperature of unit too high	<ul style="list-style-type: none"> › Allow the unit to cool down. › Contact technician.
Error code 1022	Subassembly not initialized	<ul style="list-style-type: none"> › Fault in software, update the software if required. › Contact technician.
Error code 1024	Internal data communication fault	<ul style="list-style-type: none"> › Switch the unit off and back on again. › Update the firmware. › Darken the room. › Turn the unit so that no light can fall directly into the insertion slot.
Error code 1026	Incorrect acquisition mode	<ul style="list-style-type: none"> › Select a different acquisition mode › Inform a service technician. › Update the firmware. › Reset the scanning modes to the factory settings via the unit interface or the Imaging Software.
Error code 1100	Permitted time for scan process exceeded	<ul style="list-style-type: none"> › Contact technician. › Check the belt drive. › Check for blockage, remove PSP from unit.
Error code 1104	Erasure unit fault	<ul style="list-style-type: none"> › Contact technician. › Replace the erasure unit.
Error code 1153	Unit fault	<ul style="list-style-type: none"> › Switch the unit off and on again. › Update firmware.
Error code 1154	Internal data communication fault	<ul style="list-style-type: none"> › Switch the unit off and on again. › Update firmware.
Error code 1160	Final pentaprism assembly rotation speed not reached	<ul style="list-style-type: none"> › Contact technician. › Update firmware. › Replace the pentaprism assembly if the problem occurs regularly.
Error code 1170	SOL sensor timeout Fault on the laser, SOL sensor or pentaprism assembly	<ul style="list-style-type: none"> › Contact technician. › Update firmware.
Error code 1172	SOL sensor timeout Fault on the laser, SOL sensor or pentaprism assembly	<ul style="list-style-type: none"> › Inform a service technician. › Update the firmware.

Error	Possible cause	Remedy
Error code 10000	Unit is exposed to too much light	<ul style="list-style-type: none"> › Darken the room. › Turn the unit such that no light can be directly incident in the entry slot.
Error code 10009	Internal communication error warning; unit remains ready for operation	<ul style="list-style-type: none"> › Update the firmware.
Error code 10017	Unit shuts down	<ul style="list-style-type: none"> › Wait until the unit has shut down completely
Error code 2	System error during startup of the unit	<ul style="list-style-type: none"> › Switch the unit off and back on again. › Update the firmware.
Error code -78	Storage medium (e. g. memory card or memory stick) is full	<ul style="list-style-type: none"> › Transmit image data to the computer. › Insert an empty storage medium.
	Fault during memory cleanup	<ul style="list-style-type: none"> › Press and hold the reset button while switching on the unit. › Update firmware. › Press and hold the reset button while switching on the unit.
Firmware not running	A firmware update has been carried out	<ul style="list-style-type: none"> › Switch the unit off and on again.
	Internal communication fault	<ul style="list-style-type: none"> › Switch the unit off and on again.
Settings (e.g. language) reset after unit restart	Faulty configuration file	<ul style="list-style-type: none"> › Update the firmware. › Reset the configuration to the factory settings and reconfigure.
Warning message during shutdown of the unit	Not a malfunction	<ul style="list-style-type: none"> › Update the firmware.

Appendix

15 Menu structure Settings

Device information ¹	Device data
	Dealer information
	Report
Access levels ¹	User
	Administrator
	Service technician
	Factory technician

System settings ²	Language	German (DE) English (EN) ...	
	Date & time	Date Time	
	Network	MAC address	
		Name	
		Interface	LAN WLAN
		DHCP	
		IP address	
		Subnet mask	
		Gateway	
	Acquisition settings	Patient ID	
		Last name	
		First name	
		Date of birth	
Male/female			
Pregnancy			
Comment			
X-ray station			
X-ray parameters			
Acquisition type	INTRA Child ...		
X-ray stations	Room 1		
	Room 2		
	...		
Touch screen	Brightness		
	Touch screen calibration		
Device settings	Standby		
	Standby time		
	Menu fade-out time		
	Autom. rotation		
	Query radiation dose		
	Patient ID scheme		
	Service information		
Service interval			
Operating mode	ScanManager		

Service menu ³	Testing		
	Scanning modes	Edit scanning modes	
		Display scanning modes	
	Maintenance		
	Messages		
	Diagnosis	Statistics	Display statistics counter
			Display error counter
		Manipulate	Transport
			Insert
			Erasure unit
			Pentaprism
			PMT
		Request sensor values	Sensors
			Temperatures
			Internal device voltages
Oscilloscope			
Check touch screen			
Display test images			
Factory settings	Reset scanning modes		

- ¹ visible from access level *Operator* or higher
- ² visible from access level *Administrator* or higher
- ³ visible from access level *Service Technician* or higher

16 Scanning times

The scanning time is the time required for complete scanning of image data and depends on PSP format and pixel size.

The time to image depends mainly on the computer system used and its work load. Times stated are approximate.

16.1 Intraoral

Theor. resolution (LP/mm)	24	17	10
Pixel size (µm)	21	29.4	50.5
Resolution (DPI)	1210	864	503
Intra Size 0	41 s	27 s	16 s
Intra Size 1	42 s	37 s	17 s
Intra Size 2	45 s	37 s	18 s
Intra Size 3	60 s	41 s	22 s
Intra Size 4	78 s	59 s	29 s

16.2 Extraoral Panoramic

Theoretical resolution (LP/mm)	7.4	4.9	3.7
Pixel size (µm)	67.29	100.93	134.58
Panoramic 5" x 12"	36 s	24 s	17 s
Panoramic 15 cm x 30 cm	40 s	27 s	20 s

16.3 Extraoral Ceph

Theoretical resolution (LP/mm)	7.4	4.9	2.4
Pixel size (µm)	67.29	100.93	201.87
Ceph 8" x 10"	63 s	40 s	20 s
TMJ 5" x 7"	35 s	24 s	18 s

17 File sizes (uncompressed)

The file sizes depend on the PSP format and the pixel size. File sizes stated are approximate and have been rounded upwards.

Suitable compression methods can considerably reduce the file size without loss of data.

17.1 Intraoral

Theor. resolution (LP/mm)	24	17	10
Pixel size (µm)	21	29.4	50.5
Resolution (DPI)	1210	864	503
Intra Size 0	3.49 MB	1.78 MB	0.60 MB
Intra Size 1	4.35 MB	2.22 MB	0.75 MB
Intra Size 2	5.76 MB	2.94 MB	1.00 MB
Intra Size 3	6.61 MB	3.37 MB	1.14 MB
Intra Size 4	19.65 MB	10.02 MB	3.40 MB

17.2 Extraoral Panoramic

Theoretical resolution (LP/mm)	7.4	4.9	3.7
Pixel size (µm)	67.29	100.93	134.58
Panoramic 5" x 12"	15.37 MB	7.05 MB	3.90 MB
Panoramic 15 cm x 30 cm	20.04 MB	8.64 MB	4.79 MB

17.3 Extraoral Ceph

Theoretical resolution (LP/mm)	7.4	4.9	2.4
Pixel size (µm)	67.29	100.93	201.87
Ceph 8" x 10"	21.47 MB	9.65 MB	2.49 MB
TMJ 5" x 7"	9.97 MB	4.60 MB	2.49 MB

18 Warranty

Air Techniques' Digital Products are warranted to be free from defects in material and workmanship from the date of installation for a limited period. Please visit the Air Techniques website for the most current Warranty Policies and Standard Terms and Conditions.

www.airtechniques.com/warranty



18.1 Online Warranty Registration

Quickly and easily register the new Air Techniques product online. Please have the part number and serial number available when logging into the Air Techniques online portal account at

www.airtechniques.com/portal.





Hersteller / Manufacturer:

DÜRR DENTAL SE
Höpfigheimer Str. 17
74321 Bietigheim-Bissingen
Germany
www.duerrdental.com



Manufactured for / Distributed by:

Air Techniques, Inc.
1295 Walt Whitman Road
Melville, New York 11747-3062, USA
Phone: +1 800-247-8324
Fax: +1 888-247-8481
www.airtechniques.com