

P/N 53020
P/N 53170

P/N 53021
P/N 53173

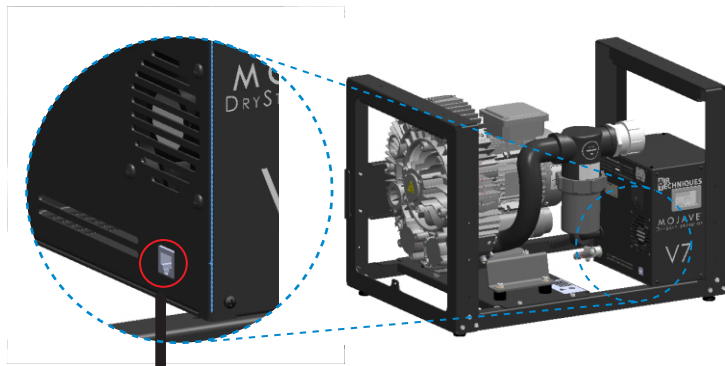

**FOR USE WITH
AIR TECHNIQUES
WATER SYSTEMS ONLY**

WATER SWITCH

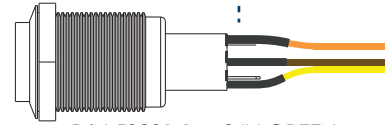

P/N 53201-1 24V GREEN

Use upper right ground stud with all solenoids and drain pump

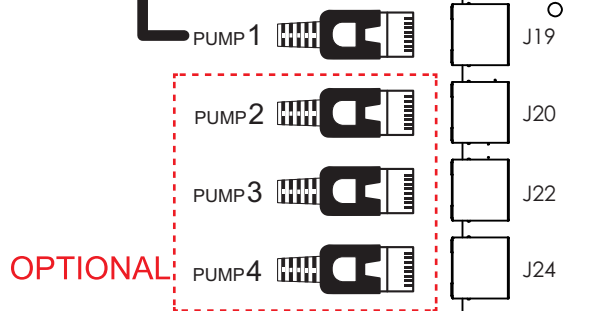
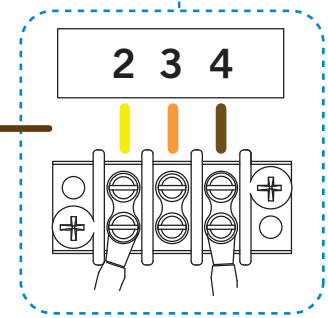
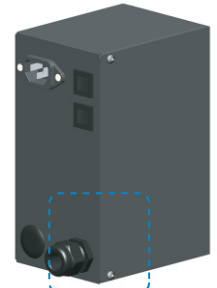

OPTIONAL

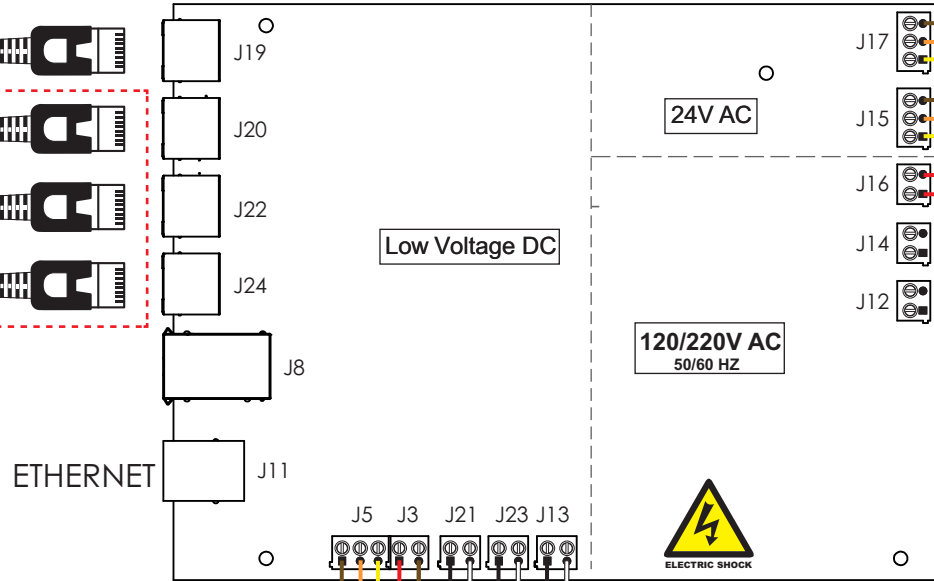

Use strain relief nearest to respective terminal block. DO NOT CROSS FEED WIRES

MASTER CONTROL PANEL SWITCH

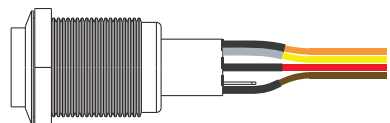

P/N 53202-1 6V GREEN/YELLOW

See users manual for detailed wiring schematic

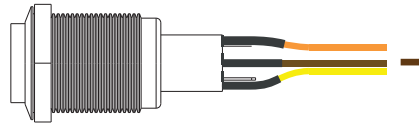

P/N 53201-1 24V GREEN

FLOAT SWITCH

FLOAT SWITCH



ELECTRIC SHOCK

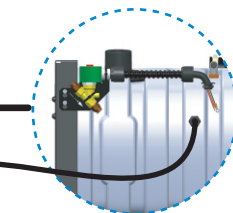

WASHOUT

WASHOUT

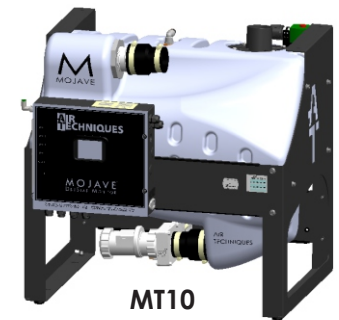

MT10

MOJAVE[®]

DRYSTAR MONITOR

MMC-M WIRING FOR MT10-M

P/N H5268M#A