

MOJAVE MONITOR

DRY VACUUM SYSTEM

PART NUMBERS V3M, V5M, V7M, 2V3M, 2V3MCT, 2V5M, 2V5MCT, 2V7M, 3V5M AND 4V5M

PRE-INSTALLATION GUIDE

All pumps comply with NFPA 99C level 3 requirements.

All installations must conform to local codes.

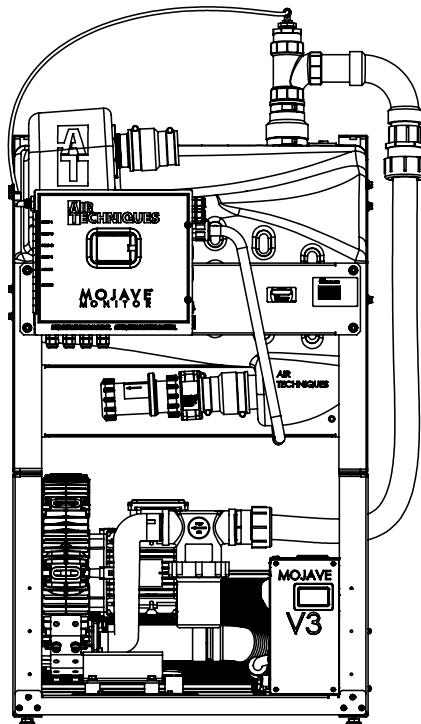

System being installed: (AS CHECKED)

- | | | | | |
|-------------------------------|---------------------------------|-------------------------------|-------------------------------|---------------------------------|
| <input type="checkbox"/> V3M | <input type="checkbox"/> V5M | <input type="checkbox"/> V7M | <input type="checkbox"/> 2V3M | <input type="checkbox"/> 2V3MCT |
| <input type="checkbox"/> 2V5M | <input type="checkbox"/> 2V5MCT | <input type="checkbox"/> 2V7M | <input type="checkbox"/> 3V5M | <input type="checkbox"/> 4V5M |

Doctor:	_____
Address:	_____
Phone#:	_____
Dealer:	_____
Dealer Address:	_____

MOJAVE SYSTEM CONFIGURATIONS

System Components										
	V3M	V5M	V7M	2V3M	2V3MCT	2V5M	2V5MCT	2V7M	3V5M	4V5M
V3M Pump Assembly	1	0	0	2	2	0	0	0	0	0
V5M Pump Assembly	0	1	0	0	0	2	2	0	3	4
V7M Pump Assembly	0	0	1	0	0	0	0	2	0	0
MT10-M / MT12-M Tank	1	1	1	1	0	1	0	0	0	0
CT20-M / CT22-M Tank	0	0	0	0	1	0	1	1	1	1
Master Controller Assembly	1	1	1	1	1	1	1	1	1	1
Maximum Users	3	7	10	6	10	14	14	20	20	25

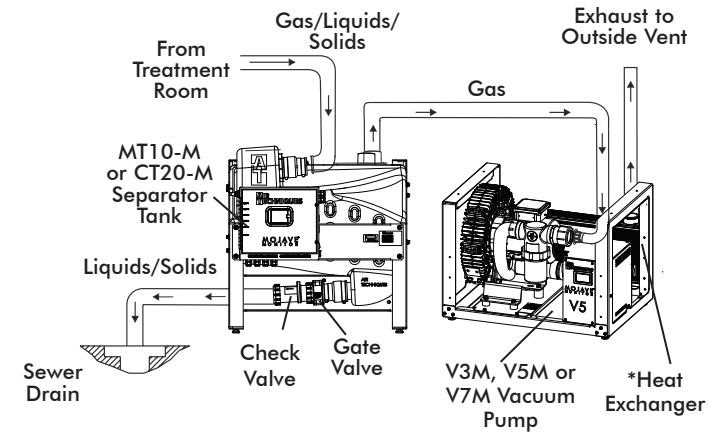

Typical MOJAVE System Installation

Recommended Number of Simultaneous HVE/SE Users

V3M		V5M		V7M		2V3 or 2V3CT		2V5M or 2V5MCT		2V7M		3V5M		4V5M			
HVE	SE	HVE	SE	HVE	SE	HVE	SE	HVE	SE	HVE	SE	HVE	SE	HVE	SE		
3	+	0	7	+	0	10	+	0	6	+	0	14	+	0	20	+	0
2	+	2	6	+	2	9	+	2	5	+	2	13	+	2	18	+	4
1	+	4	5	+	4	7	+	6	4	+	4	12	+	4	13	+	14
0	+	6	4	+	6	5	+	10	3	+	6	9	+	10	10	+	20
			0	+	14	3	+	14	2	+	8	6	+	16	8	+	24
Note:				1	+	18	1	10	2	+	24	5	+	30	5	+	30
1 HVE = 2 SE's				0	+	20	0	12	0	+	28	0	+	40	0	+	40
1 HVE = 2 Nitrous Scavengers																	

* MOJAVE Systems are available with or without a Heat Exchanger. Systems not using a Heat Exchanger are identified with the "-NHE" suffix in the associated part number.

Physical Characteristics

	Master Controller Assembly	Tanks		Typical V3M, V5M or V7M System MT10-M / MT12-M Tank Stacked onto One V3M, V5M or V7M Pump	Pump Configurations		
		MT10-M / MT12-M 10 Gallon	CT20-M / CT22-M Continuum		One V3M, V5M or V7M Pump	Two V3M, V5M or V7M Pumps Stacked	Three V5M Pumps Stacked
Width	13.5 in. (34 cm)	29 in. (74 cm)	25 in. (64 cm)	29 in. (74 cm)	25 in. (64 cm)	25 in. (64 cm)	25 in. (64 cm)
Depth	3 in. (8 cm)	22 in. (56 cm)	23 in. (58 cm)	23 in. (58 cm)	21 in. (53 cm)	21 in. (53 cm)	21 in. (53 cm)
Height	11 in. (28 cm)	33 in. (84 cm)	50 in. (127 cm)	50 in. (127 cm)	17 in. (43 cm)	34 in. (86 cm)	51 in. (130 cm)
Weight	13 Lbs. (6 kg)	75 Lbs. (34 kg)	150 Lbs. (68 kg)	220 Lbs. (100 kg)	145 Lbs. (66 kg)	290 Lbs. (132 kg)	435 Lbs. (197 kg)

ASSEMBLY DIMENSIONS

Important:

The Master Controller is mounted on the front of the MT10-M / MT12-M or CT20-M / CT22-M tank chassis. Never stack a CT20-M / CT22-M Tank on top of any Pump. Never stack a Pump on top of any Tank. Recommend pumps only be stacked a maximum of two high. All units shipped with all leveling feet set to lowest position.

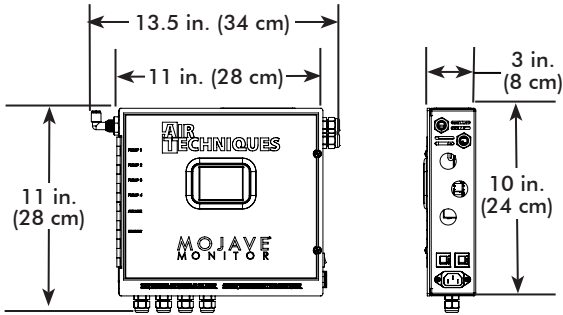

Master Controller Assembly Dimensions

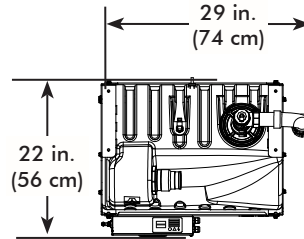

MT10-M / MT12-M 10 Gallon Tank Dimensions

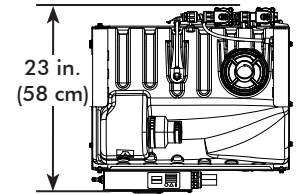

CT20-M / CT22-M Continuum Tank Dimensions

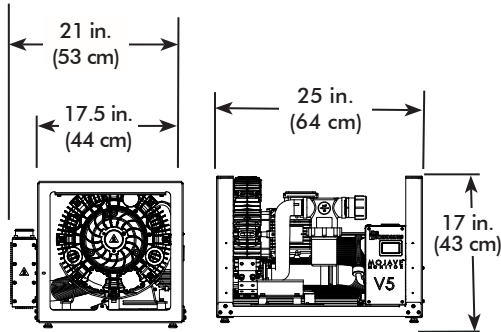

V3M, V5M and V7M Vacuum Pump Dimensions

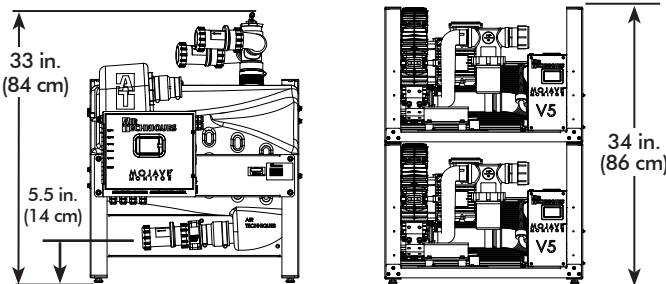
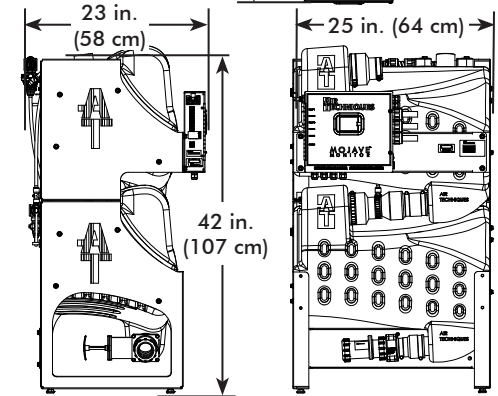
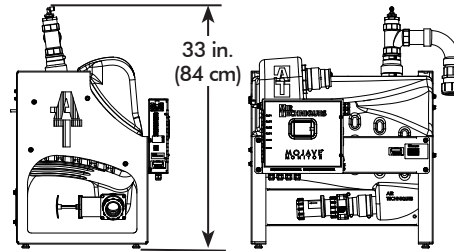

2V3M or 2V5M System Installation
Recommended Stacked Pumps with Tank on Side

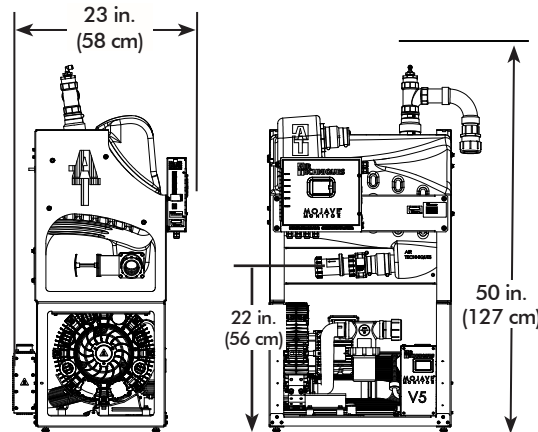

V3M, V5M and V7M System Dimensions

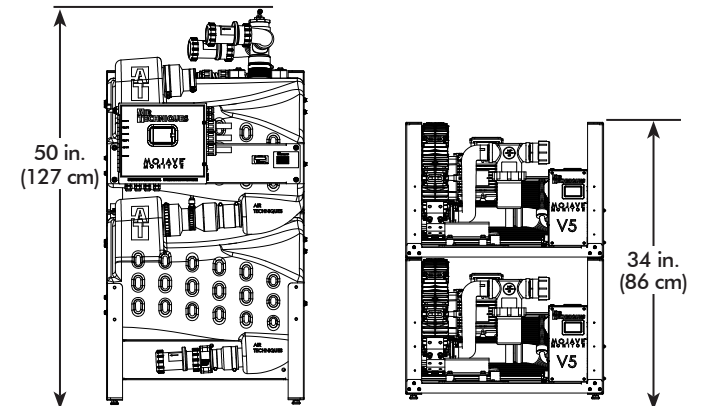

2V7M, 2V3MCT or 2V5MCT System Installation
Recommended Stacked Pumps with CT20-M / CT22-M Tank on Side

SITE REQUIREMENTS

Electrical	V3M & V5M	V7M	2V3M & 2V3MCT	2V5M & 2V5MCT	2V7M	3V5M	4V5M	Master Controller
Voltage Rating Volts AC	All pumps 220 Volts Single Phase AC, 50/60 Hz							120 / 220
Voltage Minimum/Maximum	198/242 Volts AC All pumps							108/132 Volts AC or 198/242 Volts AC
Wire Size AWG Minimum Gauge	#12 AWG (Qty 1)	#10 AWG (Qty 1)	#12 AWG (Qty 2)	#12 AWG (Qty 2)	#10 AWG (Qty 2)	#12 AWG (Qty 3)	#12 AWG (Qty 4)	#14 AWG
Minimum Panel Breaker Rating	20A	30A	20A (Qty 2)	20A (Qty 2)	30A (Qty 2)	20A (Qty 3)	20A (Qty 4)	15A
Incoming Power	Hard wire Connection (Each pump is supplied a 6 foot BX cable)							NEMA 5-15R for 120V NEMA 6-15R for 220V (Supplied 10-ft. line cord)
Remote (Low Voltage Wiring)	#18 AWG (Qty 4) Wire Connection between the MMC-M and the Remote Switch Panel .							
Optional Buck Boost Transformer	67002	67000-1	2X 67002		2X 67000-1	3X 67002	4X 67002	67002 for 220V or 67005 for 120V

Plumbing	V3M	V5M	V7M	2V3M	2V3MCT	2V5M	2V5MCT	2V7M	3V5M	4V5M
Exhaust Vent Pipe Using Heat Exchanger	2" PVC Sch. 40	2" PVC Sch. 40	2" PVC Sch. 40	One 3" or two 2" PVC Sch. 40		One 3" or two 2" PVC Sch. 40		One 3" or two 2" PVC Sch. 40	One 4" or three 2" PVC Sch. 40	Two 3" or four 2" PVC Sch. 40
Exhaust Vent Pipe Not Using Heat Exchanger (See note 1)	2" Metal Pipe	2" Metal Pipe	2" Metal Pipe	One 3" or two 2" Metal Pipe		One 3" or two 2" Metal Pipe		One 3" or two 2" Metal Pipe	One 4" or three 2" 2" Metal Pipe	Two 3" or four 2" Metal Pipe
Minimum Suction Line Pipe	1" PVC Sch. 40	1 ½" PVC Sch. 40	2" PVC Sch. 40	1 ½" PVC Sch. 40		2" PVC Sch. 40		3" PVC Sch. 40	3" PVC Sch. 40	3" PVC Sch. 40
Maximum Suction Line Pipe (See note 2)	1 ½" PVC Sch. 40	2" PVC Sch. 40	2 ½" PVC Sch. 40	2" PVC Sch. 40		2 ½" PVC Sch. 40		4" PVC Sch. 40	4" PVC Sch. 40	4" PVC Sch. 40
Riser Pipe	½" PVC Sch. 40	½" PVC Sch. 40	½" PVC Sch. 40	½" PVC Sch. 40		½" PVC Sch. 40		½" PVC Sch. 40	½" PVC Sch. 40	½" PVC Sch. 40
Vacuum Line Termination	1 ½" FNPT	1 ½" FNPT	2" FNPT	2" FNPT	3" FNPT	2" FNPT	3" FNPT	2" FNPT	2" FNPT	2" FNPT
Branch Line Pipe	Size requirement of Branch piping differs by the number of operatories being serviced.			Up to three operatories use 1" PVC Schedule 40. Four to six operatories use 1 ½" PVC Schedule 40. More that six operatories use 2" PVC Schedule 40						
Drain Line Pipe	1 ½" PVC Schedule 40									
Wash-Out Water Line	½" FNPT Shut-off Valve									

NOTES

1. Recommended pipe used with models without a heat exchanger includes wrought iron pipe (black & galvanized) or copper pipe type M. Insulate metal pipe in utility room to avoid adding heat to the room. Insulation must be rated for a minimum of 300°F continuously.
2. Use maximum internal diameter for the main line when preparing any new installation.

TYPICAL EQUIPMENT ROOM FLOOR PLAN LAYOUT

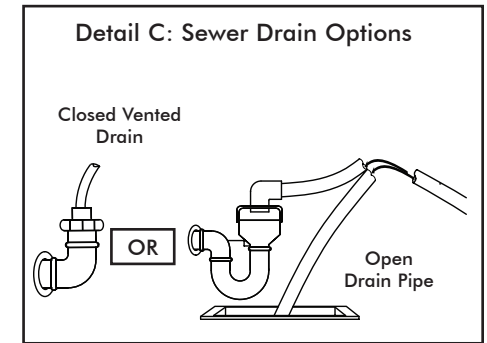
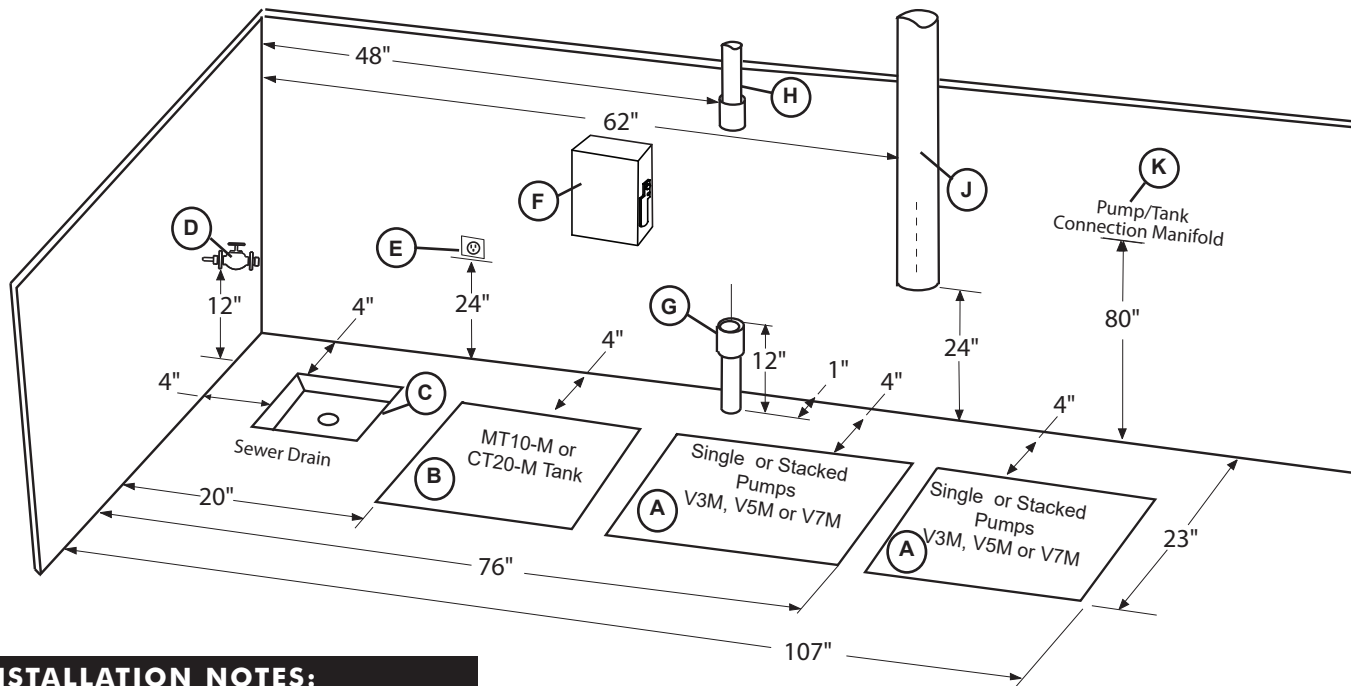

INSTALLATION NOTES:

- A. PUMP INSTALLATION SPACE** - Area for stacked or side by side pump installation. Keep 4 inch space from walls. Only stack up to 2 pumps in one area.
- B. TANK INSTALLATION SPACE** - Area for typical side by side tank installation. Keep 4 inch space from walls. Never install the CT20-M / CT22-M tank on top of a pump.
- C. SEWER DRAIN** - Provide a drain for the removal of waste liquids from the MOJAVE tank. Use an open drain pipe (1 1/2" inch P-Trap with 1 inch air gap or floor sink) or a closed vented drain. See detail C for options.
- D. TANK WASHOUT** - Provide a water source terminated with a 1/2" inch FNPT shut-off valve providing water pressure between 20 and 100 psi for daily tank washout. Valve location must be no more than 10 feet from the tank installation to allow connection of supplied 10-foot 3/8-inch Poly tubing to the tank washout port. Provisions for backflow prevention may be required. Check local code requirements.
- E. MASTER CONTROLLER ELECTRIC OUTLET** - Master Controller requires a dedicated standalone 120V, 5 AMP or 220V, 5 AMP grounded receptacle.
- F. PUMP ELECTRIC SERVICE** - Each Mojave pump is wired directly with a dedicated 220V, 20 AMP, (30 AMP for V7) single phase 60 Hz circuit. If Main Circuit panel is not located in equipment room, a disconnect box with approved ground is needed for each pump. Disconnect boxes should be mounted no more than 3 feet of each other and 3 feet of installation center line.
- G. SUB FLOOR INSTALLATION VACUUM LINE** - See Plumbing Requirements for connection to tank input via supplied hose.
- H. OVERHEAD INSTALLATION VACUUM LINE** - See Plumbing Requirements for connection to tank input via supplied hose.
- J. HEAT EXHAUST** - See Plumbing Requirements for the exhaust vent line required for specific Mojave configurations. Use metal pipe on systems whenever the Heat Exchanger is removed. Schedule 40 pipe can normally be used on typical Mojave configuration installations with a Heat Exchanger. When installing multiple pumps, see Mojave exhaust line options page.
- K. PUMP/TANK MANIFOLD** - User fabricated to connect 3 or 4 pumps to a tank. Used with 3V5M and 4V5M systems. See Pump/Tank Connection Manifold.

TREATMENT ROOM PLUMBING INSTALLATIONS

SUB FLOOR INSTALLATION -

Recommended system installation layout should be used whenever possible.

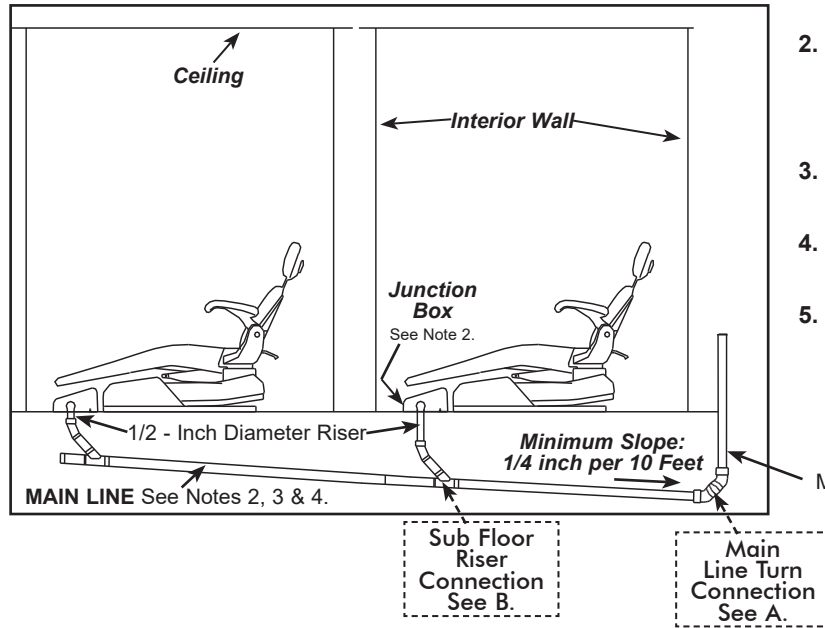

Notes:

- 10-foot Maximum Height from Main Line to Tank.
- Consult Dental Unit Manufacturer's Guidelines for correct reduced size and height of termination of vacuum line inside junction box.
- Limit branches. Orient main line under junction box or cabinet.
- When piping line is above 3/4" I.D. or larger, use 45° Y's & elbows only.
- Recommend installing separate line connection for scavenger when using Nitrous scavengers in overhead piping installations.

Main Line Riser for connection to tank input. See Note 1.

OVERHEAD INSTALLATION -

Alternate system installation layout should be used only when unable to use the sub-floor plumbing layout.

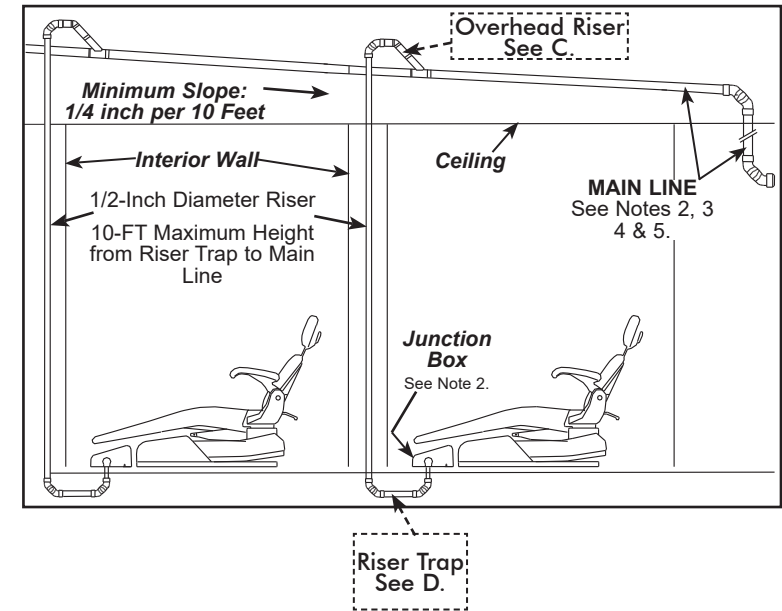

CONNECTOR DETAILS - ALL INSTALLATIONS

- Use only 45° elbows to make turns in main line.
- Make sure to use the proper pipe type for associated system.
- If piping is diverted to clear an obstruction, **DO NOT MAKE A TRAP.** See detail A, Main Line Turn Connections.
- DO NOT use standard 90° elbows.

Important:
All installation pipes and fittings provided by plumber.
All installations must conform to local codes.

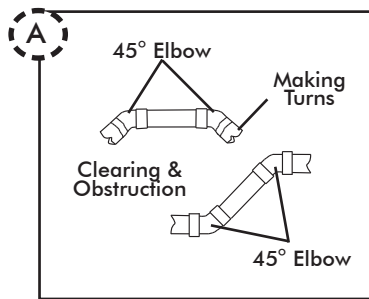

Main Line Turn Connections

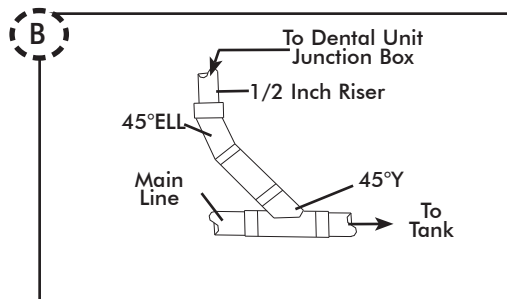

Sub Floor Riser to Main Line Detail

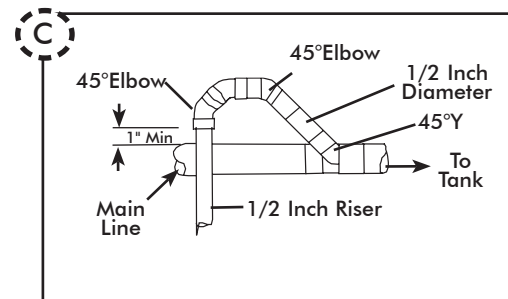

Overhead Riser to Main Line Detail
(Prevents liquids from draining down the 1/2" riser.)

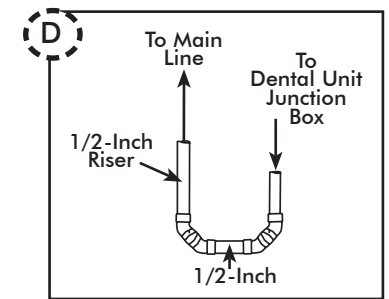

Riser Trap Detail (45° Elbows)

PUMP/TANK CONNECTION MANIFOLD

Pump/Tank Connection Manifold Using Accessory Kit

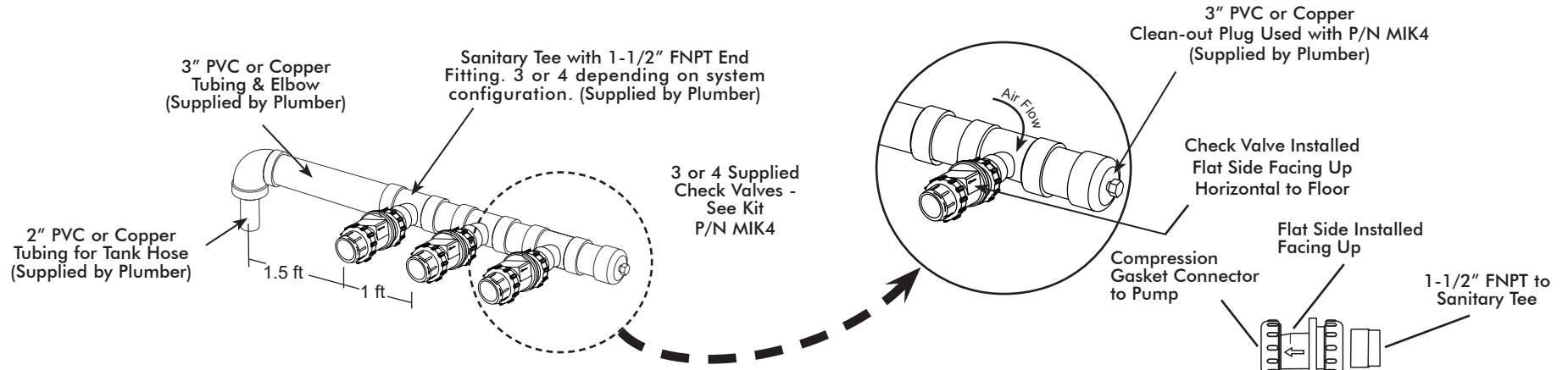

CT20 TANK INLET CONNECTION DETAIL

Note: Hang using at least 3 pipe supports supplied by Plumber.

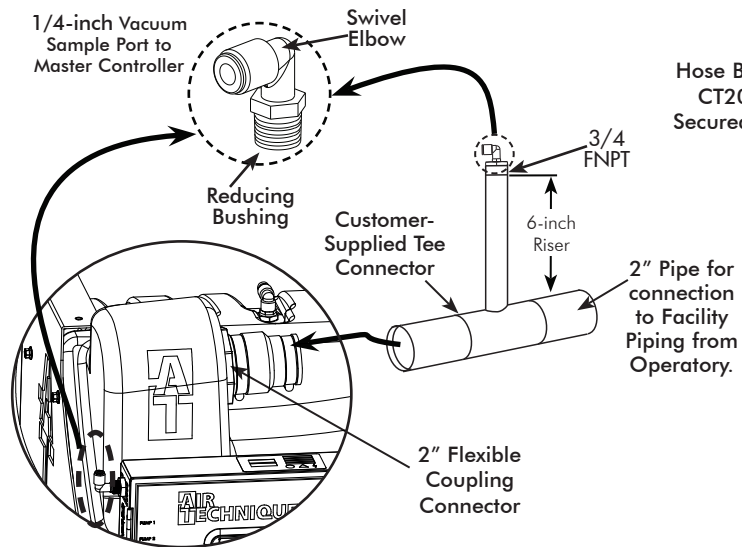

Hose Between Manifold and CT20-M / CT22-M Tank Secured by Flexible Couplers

Hoses From Manifold To Pumps

Hose Between Manifold and CT20-M / CT22-M Tank Secured by Flexible Couplers

Hoses From Manifold To Pumps

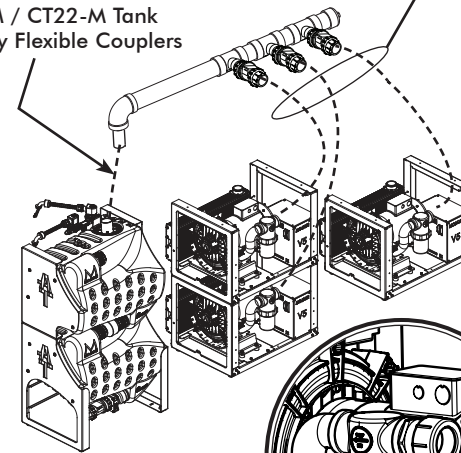

V3M, V5M & V7M PUMP HOSE CONNECTION DETAIL

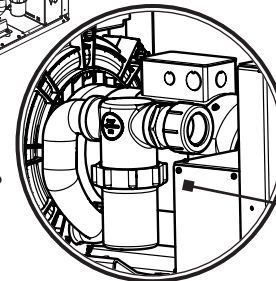

MEDICAL ELECTRICAL EQUIPMENT

WITH RESPECT TO ELECTRICAL SHOCK, FIRE, MECHANICAL AND OTHER SPECIFIED HAZARDS ONLY
IN ACCORDANCE WITH UL-60601-1, CAN/CSA C22.2 NO.601.1 66CA

MOJAVE EXHAUST LINE OPTIONS

2 INCH EXHAUST LINE

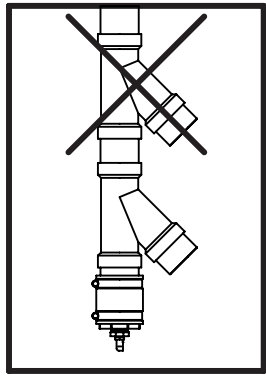

ONLY USE ONE
2" WYE PER LINE*

DRIP LEG ASSEMBLY
BELOW LINE INCLUDED.

2" x 2" x 2" WYE
2" PVC
CUT TO LENGTH

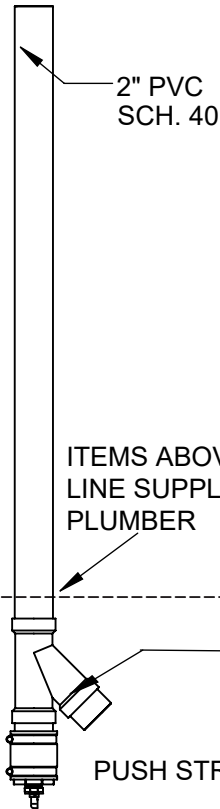

PUSH STRAIGHT

3 INCH EXHAUST LINE

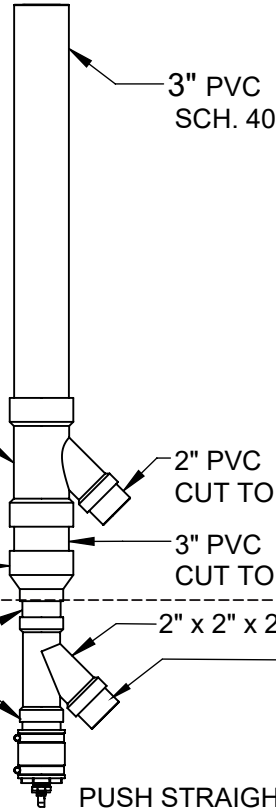

PUSH STRAIGHT

3" x 3" x 2" WYE

3" TO 2"
REDUCER

2" PVC
CUT TO LENGTH

2" PVC
CUT TO LENGTH

3" PVC
CUT TO LENGTH

2" x 2" x 2" WYE

2" PVC
CUT TO LENGTH

DRIP LEG ASSEMBLY

4 INCH EXHAUST LINE

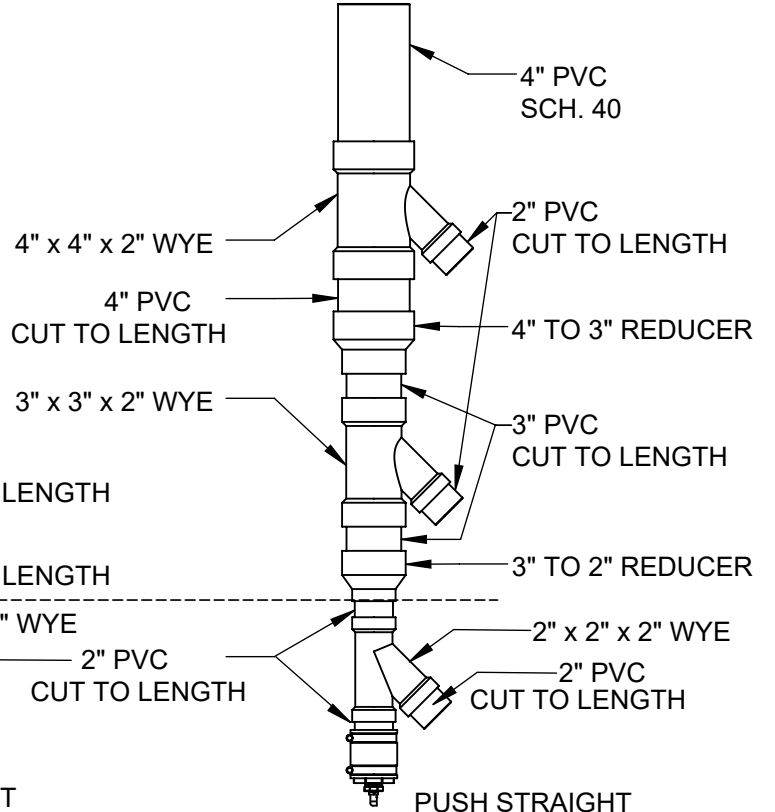

PUSH STRAIGHT

4" PVC
SCH. 40

4" x 4" x 2" WYE
4" PVC
CUT TO LENGTH

2" PVC
CUT TO LENGTH

4" TO 3" REDUCER

3" x 3" x 2" WYE

3" PVC
CUT TO LENGTH

3" TO 2" REDUCER

2" x 2" x 2" WYE

2" PVC
CUT TO LENGTH

2" EXHAUST LINE	
MODEL#	QTY
V3M, V5M, V7M	1x
2V3M, 2V5M, 2V7M	2x
3V5M	3x
4V5M	4x

3" EXHAUST LINE	
MODEL#	QTY
2V3M, 2V5M, 2V7M	1x
4V5M	2x

4" EXHAUST LINE	
MODEL#	QTY
3V5M	1x

***NOTE:** Do not use multiple 2" WYE assemblies together with a single 2" exhaust line for multi-pump systems. Make sure to take into account pump locations before assembling manifold.

EXHAUST VENTILATION REQUIREMENTS

* MOJAVE Systems are available with or without a Heat Exchanger. Systems not using a Heat Exchanger are identified with the “-NHE” suffix in the associated system part number.

HEAT EXHAUST CONNECTION NOTES

- 1. VENT LINE** - The exhaust vent line required for MOJAVE systems using the Heat Exchanger and systems without the Heat Exchanger (-NHE units) have different requirements. Use metal pipe on systems without a Heat Exchanger while PVC Schedule 40 pipe can be used on systems with a Heat Exchanger. Do not make a trap in the exhaust vent piping. Do not use 90° fittings. Also see Exhaust Vent Protection and Ventilation Requirements below.
- 2. V3M, V5M & V7M PUMP EXHAUST VENT CONNECTION** - Connection between the pump and exhaust vent piping is typically made via the supplied 2-inch Black Flex tubing.
- 3. EXHAUST VENT ASSEMBLY** - The supplied assembly must be installed at the lower end of the vent pipe to collect condensation produced during pump operation. The bottom of the Y connector should be located 18 inches from floor. Attach the drain tube to the drip leg quick-connect fitting to allow drainage into floor drain/sink.

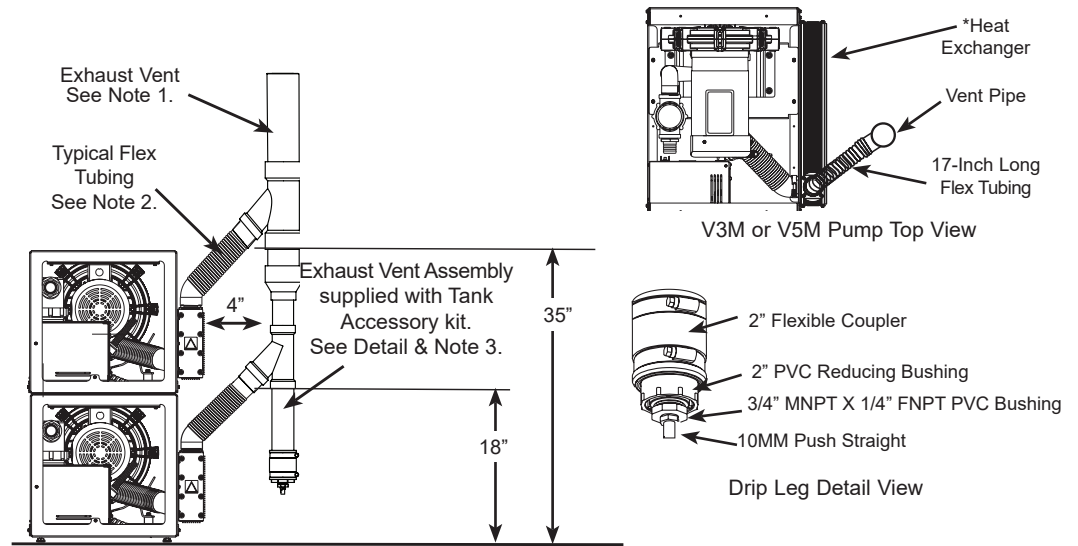

V3M, V5M & V7M Pump Heat Exchanger Connection

Exhaust Vent Protection.

If the exhaust piping is venting to the outside of the building, precautions must be taken to protect the equipment room from weather elements and animal intrusion. This can be accomplished by using one of the three methods shown on the right.

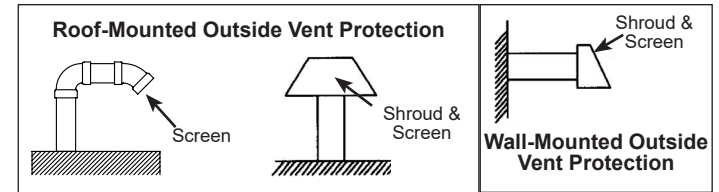

Exhaust Vent Requirements.

The MOJAVE equipment must be used in a controlled-temperature environment. Maintain equipment room temperature between 40 and 105 degrees Fahrenheit. An exhaust fan is necessary if room temperature is not maintained by other methods.

Adequate forced ventilation must be provided across the unit by placing an appropriate exhaust fan opposite an equivalent air intake vent. The fan should be placed higher than the associated intake vent. Recommended minimum exhaust fan requirements for each MOJAVE unit are listed to the right.

MOJAVE Unit	Watts (Idle)	Watts (Max)	BTU/Hr (Idle)	BTU/Hr (Max)
V3M	886	1,601	3,021	5,462
V5M	886	2,245	3,021	7,660
V7M	1,200	2,245	3,021	7,660
2V3M & 2V3MCT	886	3,202	6,042	10,924
2V5M & 2V5MCT	886	4,490	6,042	15,320
2V7M	See Note	1,200	4,490	6,042
3V5M	886	6,735	9,063	22,980
4V5M	886	8,980	12,084	30,640

Note: Only 1 pump is running when operating in idle mode.

NOTES

NOTES

For over 60 years, Air Techniques has been a leading innovator and manufacturer of dental products. Our priority is ensuring complete satisfaction by manufacturing reliable products and providing excellent customer and technical support. Whether the need is digital imaging, utility room equipment or merchandise, Air Techniques can provide the solution via our network of authorized professional dealers. Proudly designed, tested and manufactured in the U.S., our products are helping dental professionals take their practices to the next level.

Air Techniques' family of quality products for the dental professional include:

Digital Imaging

- Digital Radiography
- Intraoral Camera
- Caries Detection Aid
- Intraoral X-ray

Utility Room

- Dry Vacuums
- Wet Vacuums
- Air Compressors
- Amalgam Separator
- Utility Accessories
- Utility Packages

Nitrous Oxide

- Analog & Digital Flowmeters
- Flowmeter mounting
- Central Gas Supply: Manifold, Alarm, Zone Valve, Outlets, & accessories.
- Oxygen Delivery & Emergency delivery
- Scavenger systems & Nasal hoods

Merchandise

- Surface Disinfectant
- Enzymatic Cleaner
- Hand Sanitizer and Lotion
- Waterline Cleaner
- Evacuation System Cleaner
- Imaging Accessories
- Chemistry
- Processor Accessories

Corporate Headquarters

1295 Walt Whitman Road | Melville, New York 11747- 3062

Phone: 800-247-8324 | Fax: 888-247-8481

www.airtechniques.com



MOJAVE is a trademark of Air Techniques, Inc.
© 2022 Air Techniques, Inc. • P/N H5546, Rev. C • April 2026
