

HYDROMISER[®]

Installation & Maintenance Instructions



AIR
TECHNIQUES equipped for life[®]



Model H-2 for VacStar 20

Congratulations! Your new HydroMiser, water recycling system patented design incorporates many unique benefits:

- HydroMiser reduces VacStar's water use by up to 75%.
- A built-in air/water separator keeps air and gases from entering your sanitary waste lines.
- A built-in self-clearing drain device prevents solids from accumulating within the liquid storage reservoir.
- A unique eductor fluid control system assures proper water flow for optimum VacStar performance.

The HydroMiser, is available as Model H-2 for the VacStar 20 and Model H-4 used with VacStar 40.

Warning: The following steps must be performed while wearing skin and eye protection designed for handling typical Haz-Mat material. Use care at all times to prevent spillage.

Installation Specifications

1. Items A, D. & E are supplied.
2. Item B, 2" vent to outside is not supplied.
3. Item C, 1-1/2" sanitary waste line is not supplied.
4. If local codes prohibit a direct waste connection as shown, use hose supplied to route waste from "E" to a floor sink or to an open vertical 1-1/2" PVC waste line.

Important

- Install HydroMiser to the left, right, or above of VacStar.
- Do not install HydroMiser below VacStar.
- Maximum vertical distance between the VacStar exhaust outlet and the HydroMiser inlet is 3 feet. (36 in.)

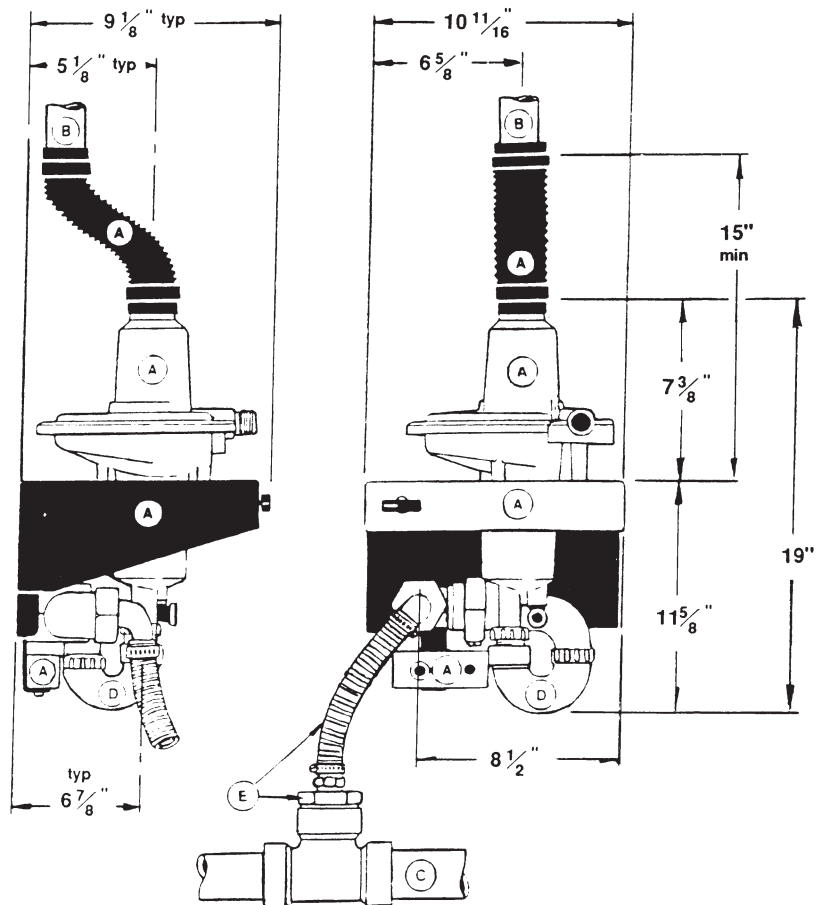

Installation Procedure

NOTE:

Figure 1 shows VACSTAR 20.

VACSTAR 40 is similar except main power connection is made via provided hospital grade NEMA 6-15P line cord.

1. Preparing VacStar

- A. Cut 3/8" Poly-Fio tubing (A), midway between (B) and (C)
- B. Install supplied union connectors on the cut end of each tubing section.
 - The 1/4" X 3/8" reducing union is installed to the upper (B to A) tubing section.
 - The 3/8" X 3/8" union is installed to the lower (C to A) tubing section.

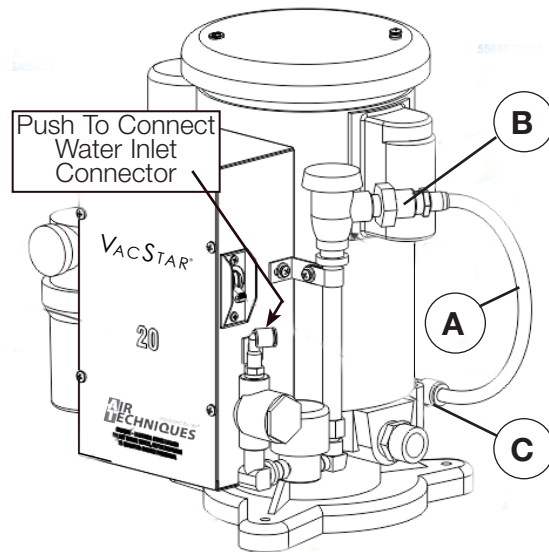

Figure 1. VacStar 20 and 40 Preparation

2. Water Pressure Regulator Installation

As shown by Figure 2, install the supplied pressure regulator on the water supply line.

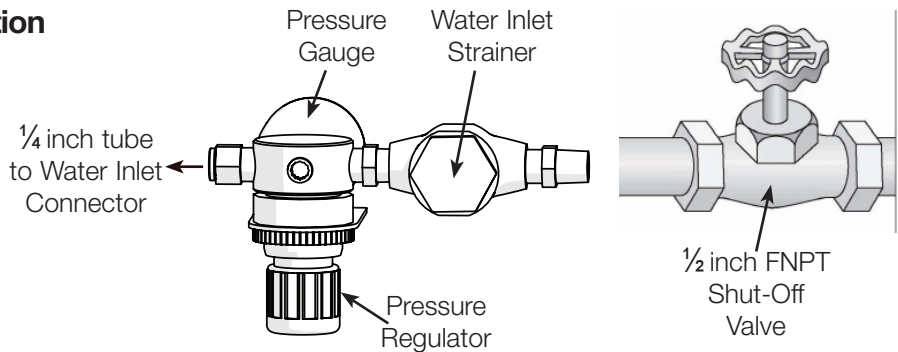

Figure 2. Pressure Regulator Installation

3. Connections between the VacStar and HydroMiser

Connect the 1/4" tubing, the 3/8" tubing and the 3/4" hose between HydroMiser and the VacStar as shown by Figure 3.

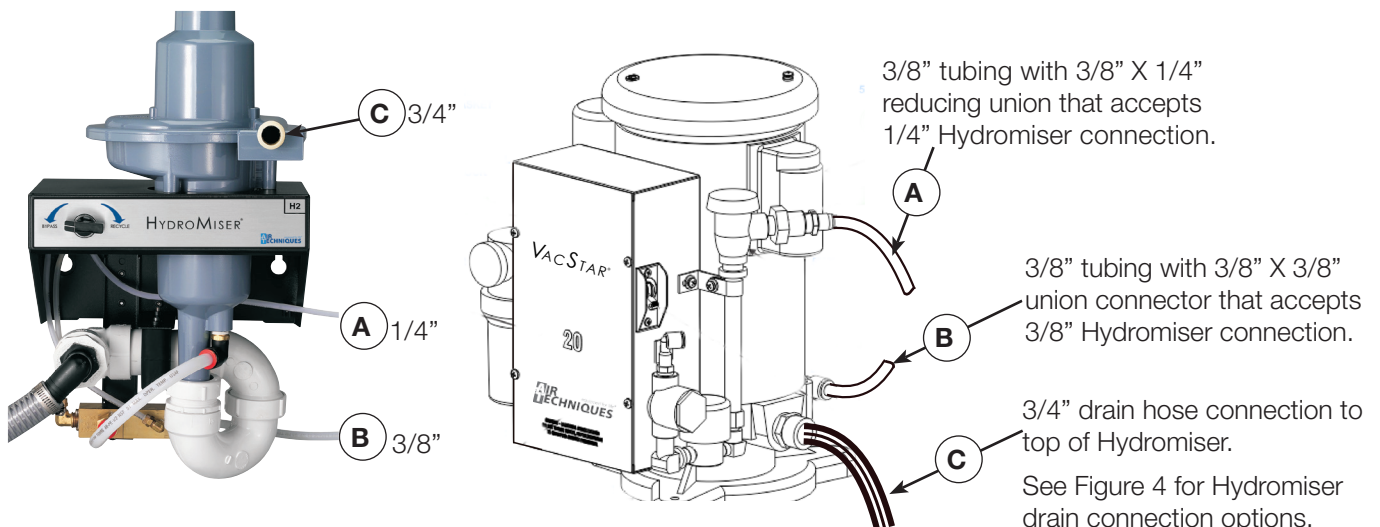

Figure 3. HydroMiser Installation

**IMPORTANT NOTE:
ALL INSTALLATIONS**

Ambient temperature for all VacStar installations should be 40°- 104°F (5°- 40°C).

The liquid drain from the HydroMiser must slope downward at least 1/4" for every 10 feet of run toward the drain.

(Avoid local low sections, avoid creating traps in the line.)

1" hose for Hydromiser either drain connection option shown below.

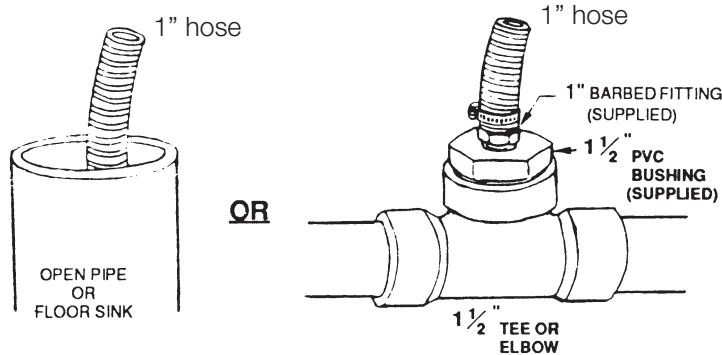

Figure 4. Drain Connection Options

Maintenance

Required - Not Supplied

<u>Part No.</u>	<u>Description</u>
57850	2.5 Liter Bottle CleanStream Cleaner (125 applications)
57665	CleanStream Dispenser System 1 Bottle with o-rings and caps 1 Saliver Ejector Adapter 1 High-Volume Actuator Adapter 1 Small Suction Hose Adapter 1 Large Suction Hose Adapter



Part No. 57850



CleanStream Dispenser System,
Part No. 57665

Warning: The following steps must be performed while wearing skin and eye protection designed for handling typical Haz-Mat material. Use care at all times to prevent spillage.

Caution: Use only CleanStream Cleaner to maintain the system vacuum lines. Do not use chlorine bleach or solutions of sodium hypochlorite to disinfect the MOJAVE system. These materials may result in damage or destruction of equipment or loss of system performance.

Daily Maintenance - Clean Vacuum Lines

Follow directions provide with product instructions and clean all vacuum lines in the vacuum system with CleanStream Cleaner daily as part of the overall preventive maintenance program. This helps to maintain the cleanliness of the tank as well as the vacuum lines and tubing throughout the system. Using the 2.5 liter bottle of CleanStream Cleaner, PN 57850 and the CleanStream dispenser system, PN 57665.

www.airtechniques.com



Air Techniques
1295 Walt Whitman Road
Melville, New York 11747

