

VistaPano S 2.0

VistaPano S Ceph 2.0



EN-US Operating instructions



RxOnly



2208100023L21 A9301 2604V006

The latest version of the instructions is available in this page:



<https://bit.ly/m/air-techniques-imaging-manuals>

Contents



Important information

1 About this document	3
1.1 Warnings and symbols	3
1.2 Copyright information	4
2 Safety	4
2.1 Indications for use	4
2.2 Improper use	4
2.3 General safety information	5
2.4 Systems, connection with other devices	5
2.5 Radiation protection	5
2.6 Specialist personnel	5
2.7 Protection from electric shock	6
2.8 Elements that patients will come into contact with	7
2.9 Protection from cybersecurity threats	7
2.10 Notification requirement of serious incidents	7
2.11 Only use genuine parts	7
2.12 Transport	7
2.13 Disposal	8



Product description

3 Overview	9
3.1 Scope of delivery	11
3.2 Accessories	11
3.3 Optional items	11
3.4 Consumables	11
4 Technical data	12
4.1 X-ray tube performance data	14
4.2 Electromagnetic compatibility (EMC)	16
4.3 Dimensions	19
4.4 Model identification plate	23
4.5 Conformity assessment	23
5 Function	24
5.1 Panoramic X-ray device	24
5.2 Cephalometric X-ray unit	24

5.3 Operating elements	24
5.4 Status LED	25
5.5 Positioning aids panoramic image	25
5.6 Positioning aids for cephalometric projections	26
5.7 Exposure button	26
5.8 Sensor window	27



Usage

6 Operating the touch screen	28
6.1 Navigating	28
6.2 Using menus	28
6.3 Calling up messages on the touch screen	28
7 Operation	29
7.1 Operating the unit – a brief overview	29
7.2 Switch the device on	29
7.3 Making settings in the imaging software	30
7.4 Panoramic X-ray device	37
7.5 Positioning the patient	40
7.6 Cephalometric exposure	43
7.7 Start a test run	46
7.8 Taking the X-ray image	47
7.9 EMERGENCY OFF	48
8 Cleaning and disinfection	49
8.1 Surface of the unit	49
8.2 Positioning aids	50
9 Reprocessing	51
9.1 Risk analysis and classification	51
9.2 Reprocessing procedures	51
9.3 General information	52
9.4 Preparation at the operating location	52
9.5 Clean manually, perform a final rinse, dry	53
9.6 Automatic cleaning, intermediate rinsing, disinfection, final rinse, drying	53
9.7 Check for function	53

9.8	Steam sterilization	54	17.4	Ceph, lat	80
9.9	Issue clearance for the parts for sterilization	54	18	Information on the leakage rate	82
9.10	Storing parts for sterilization	54	18.1	Measuring conditions	82
10	Quality control	55	18.2	Standard Pano	82
10.1	Applicable standards in Germany	55	18.3	Ceph	84
10.2	Applicable standards in other countries	55	19	Warranty	86
10.3	Consistency check	55			
10.4	Quality control measures	59			
11	Maintenance	61			
11.1	Recommended maintenance schedule	61			

Installation

12	Establishing the electrical connections	64
12.1	Electrical safety when making connections	64



Troubleshooting

13	Tips for operators and service technicians	65
-----------	-------------------------------------------------------------	-----------



Appendix

14	Default values	66
14.1	Pano	66
14.2	Ceph	68
15	Panoramic program parameters	70
15.1	Large built patient	70
15.2	Average built patient	71
15.3	Small patient	72
15.4	Child (<12 years)	73
16	Ceph program parameters	75
16.1	Large built patient	75
16.2	Average built patient	75
16.3	Small patient	76
16.4	Child (<12 years)	76
17	Information on scattered radiation	78
17.1	Measuring conditions	78
17.2	Pano, adult	78
17.3	Pano, pediatric	79

 **Important information**

1 About this document

These operating instructions apply to:

VistaPano S 2.0

REF: A9350

VistaPano S Ceph 2.0

REF: A9550

These installation and operating instructions are an integral part of the unit.



Air Techniques shall not be held liable and offers no guarantees of the safe and smooth operation of this unit if you fail to comply with notes and instructions contained in these Operating Instructions.

Refer to the separate installation instructions for information about assembly, installation and configuration of the unit.

1.1 Warnings and symbols

Warnings

The warning notes in this document highlight possible injury to persons or damage to machinery.

They are marked with the following warning symbols:



General warning symbol



Warning – risk of dangerous electric voltages



Warning – X-rays

The warnings are structured as follows:



SIGNAL WORD

Description of type and source of danger

Here you will find the possible consequences of ignoring the warning

- Follow these measures to avoid the danger.

The signal word differentiates between different levels of danger:

- **DANGER**
Direct danger of severe injury or death
- **WARNING**
Possible danger of severe injury or death
- **CAUTION**
Risk of minor injuries
- **NOTICE**
Risk of extensive material/property damage

Miscellaneous symbols

These symbols are used in the document and on or in the unit:



Note, e.g. specific instructions regarding the efficient use of the unit.



Take note of the accompanying electronic documents.



Refer to Operating Instructions.



Medical device



Part number



Serial number



CE labeling with the number of the notified body



UL classification



Caution: By virtue of Federal Law (US-FDA 21CFR801.109), the device may only be sold to dentists or bought on behalf of a dentist.



Manufacturer



Date of manufacture



Distributor



Type B Applied Part



Do not reuse



Sterilize with steam at 134 °C



Wear hand protection.



Disconnect all power from the unit.



Off



On



Class 1 laser product



Protective ground connection



Warning – risk of dangerous electric voltages



Alternating Current



Warning against electrostatic discharge

1.2 Copyright information

All circuits, processes, names, software programs, and devices mentioned in this document are protected by copyright.

Any reprinting of the installation and operating instructions, in whole or in part, is only permitted with the written approval of the owner of the corresponding rights.

2 Safety

The unit has been developed and designed appropriately such that hazards are largely excluded if the unit is used in accordance with its Normal Use.

Despite this, the following residual risks can remain:

- Personal injury due to incorrect use/misuse
- Personal injury due to mechanical effects
- Personal injury due to electric shock
- Personal injury due to radiation
- Personal injury due to fire
- Personal injury due to thermal effects to skin
- Personal injury due to lack of hygiene, e.g. infection

2.1 Indications for use

The unit is intended to produce panoramic or cephalometric digital x-ray images. It provides diagnostic details of the dento-maxillofacial, sinus and TMJ for adult and pediatric patients. The system also utilizes carpal images for orthodontic treatment. The device is to be operated by physicians, dentists, and x-ray technicians.

2.2 Improper use

Any use of this appliance/these appliances above and beyond that described in the Installation and Operating Instructions is deemed to be incorrect usage. The manufacturer cannot be held liable for any damage resulting from incorrect usage. The operator will be held liable and bears all risks.

2.3 General safety information

- Always comply with the specifications of all guidelines, laws, and other rules and regulations applicable at the site of operation for the operation of this unit.
- Check the function and condition of the unit prior to every use.
- Do not convert or modify the unit.
- The unit must only be checked and repaired by a technician authorized by Vatech.
- Comply with the specifications of the Installation and Operating Instructions.
- The Installation and Operating Instructions must be accessible to all operators of the unit at all times.
- It is prohibited by law to modify the unit in any way that could endanger the safety of persons.
- Only use accessories and parts for this unit that have been supplied by Vatech or a third-party supplier approved by Vatech.

2.4 Systems, connection with other devices

Additional devices connected to medical electrical devices must be proven to conform with their corresponding IEC or ISO standards. All configurations must continue to comply with the standard requirements for medical systems (see IEC 60601-1).

Anyone connecting additional devices to medical electrical devices is a system configurer and is therefore responsible for ensuring that the system meets the standard requirements for systems. It shall be noted that local laws take precedence over the requirements outlined above.

2.5 Radiation protection

- Comply with all applicable X-ray protection regulations and X-ray protection measures.
- Use the prescribed X-ray protection equipment.
- In order to reduce the level of X-ray exposure, we recommend the use of bismuth, lead shielding or protective aprons, especially for children and teenagers.
- The persons operating the equipment must keep away from the X-ray unit while the exposure is being taken. The minimum distance required by the law must be maintained
- Children and pregnant women must consult a doctor before recording an X-ray image.
- No person other than the patient is permitted to be present in the radiation room without X-ray protection measures. In exceptional circumstances another person may be present to provide assistance, but this must not be a member of the surgery staff. When the exposure is being taken, make sure that you have visual contact to the patient and to the unit.
- The radiation room must be lockable to prevent entry by unauthorized persons.
- If a fault occurs, abort the exposure immediately by releasing the trigger button.
- The status LED displays when an X-ray image acquisition has been triggered.
It is optionally also possible to enable or interrupt X-ray exposures via a door contact.
- The parts connected to the unit, e. g. cables, must comply with the relevant IEC standards (e. g. IEC 60950 for IT equipment and IEC 60601-1 for medical electrical equipment)

2.6 Specialist personnel

Qualification

Legally qualified persons such as a dentist and healthcare professional for X-ray device operation.

Knowledge

- Understand the diagnosis and treatment of dental diseases.
- Understand specific terminology and instructions for the hardware and software of medical diagnostic X-ray equipment.
- Understanding of the connection, installation and operating conditions of the devices.

Language understanding

Understands English or other languages provided in the manual.

Experience

- Understands the objective and effect of diagnosing and treating dental diseases with diagnostic medical radiation devices.
- Understands how to operate diagnostic medical radiation equipment.
- Understands the contents of the user manual.

2.7 Protection from electric shock

- Comply with all the relevant electrical safety regulations when working on the unit.
- Never touch the patient and unshielded plug connections of the device at the same time.
- Replace damaged cables or plugs immediately.
- If the user of this unit requires continuous operation during power failure, an uninterruptible power supply may be required to maintain operation.



WARNING

Contraindication due to radio frequency signals

Electrical radio frequency signals can interfere with the function of pacemakers and defibrillators.

- › Patients with pacemakers or defibrillators should not be treated with this unit.



WARNING

Electric shock due to missing protective earth

- › To avoid the risk of electric, this equipment must only be connected to a supply mains with protective earth.

Comply with the EMC rules concerning medical devices

The unit meets the requirements according to IEC 60601-1-2:2020.

- The quality of the mains voltage should correspond to that of a typical commercial or hospital environment.

- Electromagnetic disruptions can lead to a loss of system performance. Therefore it may be necessary to remove devices that generate static electricity in the surrounding area, or to remove the user's static electricity before use.
- The unit is intended for use in professional healthcare facilities (in accordance with IEC 60601-1-2). If the unit is operated in any other environment, potential effects on the electromagnetic compatibility must be taken into account.
- Do not operate the unit in the vicinity of RF surgical instruments or MRT equipment.
- Maintain a minimum distance of at least 30 cm (12 in) between the unit and other electronic devices.
- Maintain a distance of at least 20 cm (8 in) between the device and wireless devices such as RFID/NFC with 134.2 kHz and 13.56 MHz.
- Note that cable lengths and cable extensions have effects on electromagnetic compatibility.

No maintenance measures are required to maintain the basic EMC safety.

- Floor coverings should be made of wood, concrete or ceramic tile. If synthetic material is installed, then the relative humidity must be at least 30%.
- The emissions characteristics of this unit make it suitable for use in industrial areas and hospitals (CISPR 11, Class A). When used in a residential environment (which normally requires Class B in accordance with CISPR 11), this device may not provide adequate protection from radio communication services. The operator may need to take corrective measures such as relocating or reorienting the device.



NOTICE

Negative effects on the EMC due to non-authorized accessories

- › Only use accessories that have been specified or approved by the manufacturer.
- › The use of any other accessories may result in increased electromagnetic interference emissions or the unit having reduced electromagnetic immunity, leading to a faulty operation mode.

**NOTICE****Erroneous operation mode due to use immediately adjacent to other devices or with other stacked devices**

- › Do not stack the unit together with other devices.
- › If this is unavoidable, the unit and other devices should be monitored in order to ensure that they are working correctly.

**WARNING****Reduced performance characteristics due to insufficient distance between unit and portable RF communication devices**

- › Portable RF communication devices, including peripheral devices such as antenna cables and external antennae, should not be used closer than 30 cm (12 inches) to any part of the VistaPano S or VistaPano S Ceph, including cables specified by the manufacturer. Otherwise this can impair the performance of this device.

2.8 Elements that patients will come into contact with

**Type B Applied Part**

- Protective covers for bite block
- Temple support plus
- Comfort bite foam set
- Comfort bite block
- Bite block
- Holder for bite block
- Chin support for maxillary joint image
- Chin holder for edentulous jaws
- Chin support for sinus image
- Ear cushions and nose support covers
- Carpus plate

2.9 Protection from cybersecurity threats

The unit is to be connected to a computer that can be connected to the Internet. Therefore, the system needs to be protected from threats from the Internet.

- Use antivirus software and update it regularly.
- Look for evidence of possible virus infection and, if applicable, check with the antivirus software and remove the virus.
- Perform regular data backups.
- Restrict access to units to trustworthy users, e.g. via a user name and password.
- Make sure that only trustworthy content is downloaded. Install manufacturer-authenticated software and firmware updates only.

2.10 Notification requirement of serious incidents

The operator/patient has to report any serious incident related the product to the manufacturer and the competent authority of the Member State, in which the operator and/or patient is established/resident.

2.11 Only use genuine parts

- Only use accessories and optional items that have been recommended or specifically approved by the manufacturer.
- Only use original working parts and spare parts.



Manufacturer and distributor accept no liability for damage or injury resulting from the use of non-approved accessories or optional accessories, or from the use of non-original wear parts or replacement parts.

The use of non-approved accessories, optional items or non-genuine wear parts / replacement parts (e. g. mains cable) can adversely affect the electrical safety and EMC.

The following accessories may affect EMC:

- Power Cable
- Exposure switch

2.12 Transport

The original packaging provides optimum protection for the unit during transport.

If required, original packaging for the unit can be ordered.



Manufacturer and distributor shall not accept any responsibility or liability for damage occurring during transport due to the use of faulty packaging, even where the unit is still under guarantee.

- Only transport the unit in its original packaging.
- Keep the packing materials out of the reach of children.
- Reattach the transport locking devices.
- Do not expose the unit to any strong vibrations or shocks.
- Do not bump or pull the unit.

2.13 Disposal

The equipment contains - in some of its parts - solid and liquid substances which must be disposed of at appropriate recycling centers conforming to all local, state and federal regulations. In particular, the equipment contains the following materials and/or components.

X-ray emitter

Non-biodegradable plastic materials, metals, glass, dielectric oil, lead, tungsten.

Other components

Non-biodegradable plastics, metals, printed circuits, and electronic components.

Air Techniques is not responsible for disposal of the apparatus or parts thereof and for the related expenses.

 Product description

3 Overview

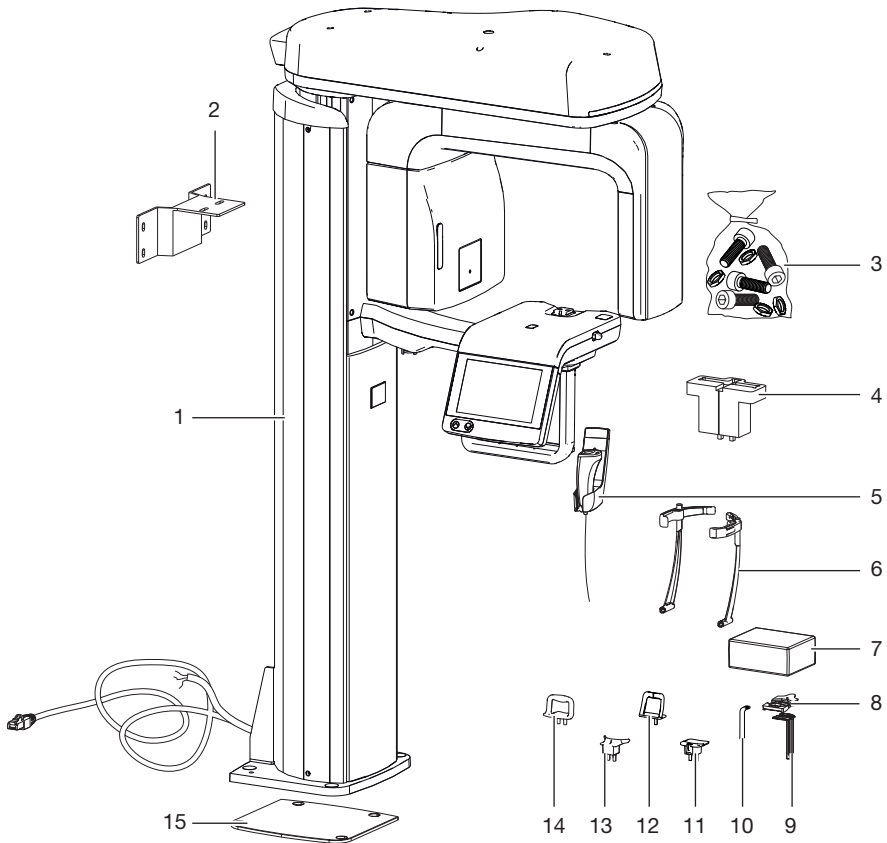

Fig. 1: VistaPano S 2.0

- | | | | |
|---|----------------------------------------|----|-----------------------------------------|
| 1 | Panoramic X-ray device | 9 | Comfort bite block* |
| 2 | Wall bracket | 10 | Bite block* |
| 3 | Installation mounting hardware | 11 | Holder for bite block* |
| 4 | Test phantom holder for ProVecta S-Pan | 12 | Chin support for maxillary joint image* |
| 5 | Exposure switch | 13 | Chin holder for edentulous jaws* |
| 6 | Temple support plus* | 14 | Chin support for sinus image* |
| 7 | Protective bite block covers* | 15 | Aligning plate |
| 8 | Comfort bite foam set* | | |

*These parts will be in direct contact with the patient.

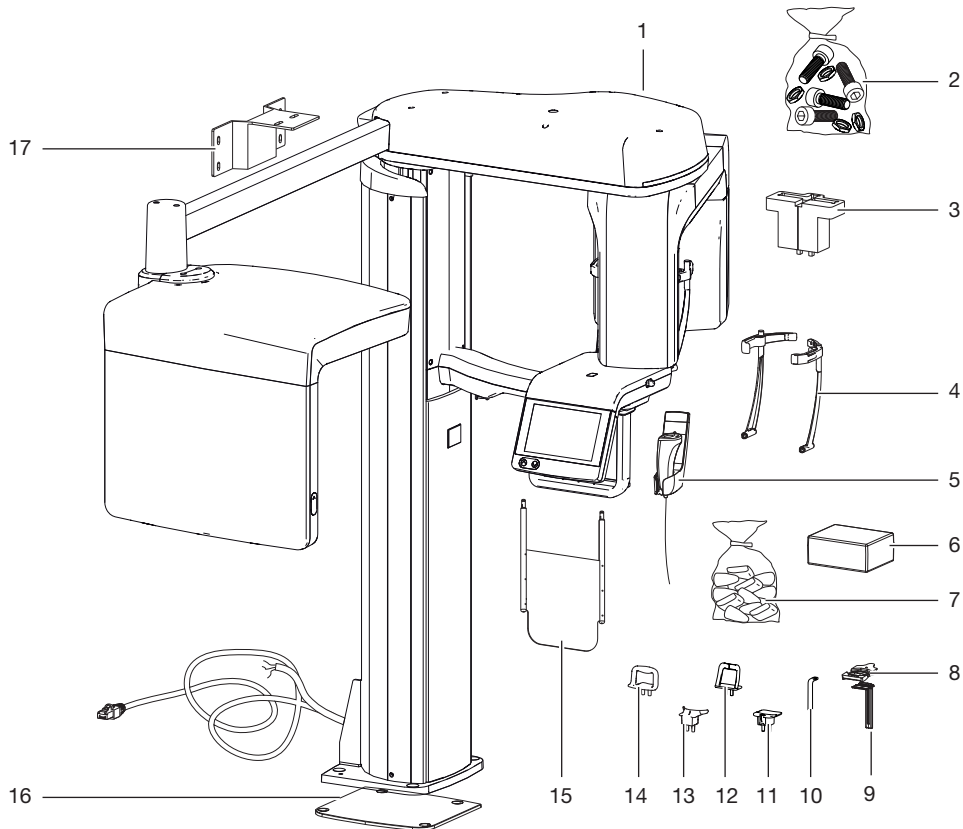

Fig. 2: VistaPano S Ceph 2.0

- | | | | |
|---|----------------------------------------|----|-----------------------------------------|
| 1 | X-ray system | 10 | Bite block* |
| 2 | Installation mounting hardware | 11 | Holder for bite block* |
| 3 | Test phantom holder for ProVecta S-Pan | 12 | Chin support for maxillary joint image* |
| 4 | Temple support plus* | 13 | Chin holder for edentulous jaws* |
| 5 | Exposure switch | 14 | Chin support for sinus image* |
| 6 | Protective bite block covers* | 15 | Carpus plate* |
| 7 | Ear cushions and nose support covers* | 16 | Aligning plate |
| 8 | Comfort bite foam set* | 17 | Wall bracket |
| 9 | Comfort bite block* | | |

*These parts will be in direct contact with the patient.

3.1 Scope of delivery

The following items are included in the scope of delivery (possible variations may apply due to country-specific requirements and/or import regulations):

VistaPano S 2.0 A9350

- Voucher for VistaSoft imaging software
- Network cable, 10 m
- Exposure switch and holder
- Holder for bite block
- Bite block
- Comfort bite block
- Chin support for edentulous jaws
- Chin holder for maxillary joint image
- Chin holder for sinus image
- Temple support plus
- Protective bite block covers (100 pieces)
- Comfort bite foam set (10 pcs.)
- Installation mounting hardware
- Silicone cap-set
- Wall bracket set
- Aligning plate
- Quick start guide
- PCI Express Gigabit Ethernet card

VistaPano S Ceph 2.0 A9550

- Voucher for VistaSoft imaging software
- Network cable, 10 m
- Exposure switch and holder
- Holder for bite block
- Bite block
- Comfort bite block
- Chin support for edentulous jaws
- Chin holder for maxillary joint image
- Chin holder for sinus image
- Temple support plus
- Protective bite block covers (100 pieces)
- Comfort bite block set (10 pcs.)
- Ear cushions and nose support covers
- Installation mounting hardware
- Silicone cap-set
- Carpus plate
- Wall bracket set
- Aligning plate
- Quick start guide
- PCI Express Gigabit Ethernet card

3.2 Accessories

The following items are required for operation of the device, depending on the application:

- Laser test tool A7385
- Ball phantom A7330
- Protective bite block covers (100 pieces) . A7395
- Test phantom holder (can be used with test phantom set for Pano 2121-060-55 and with test phantom 2121-060-54) A7366
- Test phantom holder for cephalometric projections (can be used with test phantom set for Pano 2121-060-55 and with test phantom 2121-060-54) A7557

Positioning aids

- Holder for bite block A7747
- Bite block (3 pieces) A7751
- Comfort bite foam set (10 pcs.) A7745
- Comfort bite foam set (100 pcs.) A7746
- Chin support for edentulous jaws A7390
- Head supports with cushion A7800
- Chin holder for mandibular joint image . . A7391
- Chin holder for sinus image A7392

3.3 Optional items

The following optional items can be used with the device:

- Floor stand A7355
- Laser test tool A7385
- Ball phantom A7330
- Silicone Cap-set A9347

Acceptance and consistency check

- 2-D X-ray test phantom set A7556
- Primary absorber, Copper filter A7466

3.4 Consumables

The following materials are consumed during operation of the device and must be re-ordered:

- Protective bite block covers (100 pieces) . A7395
- Comfort bite foam set (100 pieces) A7746

4 Technical data

Electrical data of the device

Nominal Voltage	V AC	200 - 240
Max. mains voltage fluctuation	%	±10
Frequency	Hz	50/60
Maximum power	kVA	2.2
Type of protection		IP X0
Operating mode height adjustment		max 2 min ON / 18 min OFF (Ratio 1:9 switch-on/switch-off time)
Operating mode		Non-continuous operation (NFPA 70: long time operation) Needs waiting time (at least 60 times the exposure time) before the next exposure begins.

Classification

Medical device class	IIb
FDA classification (CFR Title 21)	II
Health Canada Classification (SOR/98-282)	II
Protection against electric shock	Class I



UL classification

MEDICAL - APPLIED ELECTROMAGNETIC RADIATION EQUIPMENT
AS TO ELECTRICAL SHOCK, FIRE AND MECHANICAL HAZARDS ONLY IN ACCORDANCE WITH
ANSI/AAMI ES 60601-1:2005 + AMD1:2012 + AMD2:2021,
CAN/CSA-C22.2 No. 60601-1:14 (Amendment 2:2022)
IEC 60601-1-3:2008 + AMD1:2013 + AMD2:2021
IEC 60601-1-6:2010 + AMD1:2013 + AMD2:2020
IEC 60601-2-63:2012 + AMD1:2017 + AMD2:2021

Manufacturer:

VATECH Co., Ltd. on behalf of Air Techniques
13, Samsung 1-ro 2-gil, Hwaseong-si, Gyeonggi-do,
Korea

Authorized EU representative:

VATECH GLOBAL FRANCE SARL
49 Quai de Dion Bouton, AVISO A 4ème étage, 92800
Puteaux, France

Product	Digital X-ray imaging system
Model	VistaPano S VistaPano S Ceph

General technical data		VistaPano S 2.0	VistaPano S Ceph 2.0
Height	mm		1587 - 2287
Height incl. stand (optional)	in		62.48 - 90.04
	mm		1615 - 2315
	in		63.58 - 91.14
Dimensions (W x D)	mm	990 x 1160	1900 x (1145 - 1160)
	in	38.97 x 45.67	74.80 x (45.08 - 45.67)
Vertical adjustment travel of telescopic column	mm	700	700
	in	27.56	27.56
Weight	kg	112.5	134.8
Weight incl. stand (optional)	lbs	248.0	297.2
	kg	158	180.3
	lbs	348.3	397.5

Ambient conditions during operation			
Temperature		°C	10 - 35
		°F	50 - 95
Relative humidity		%	30 - 75
Air pressure		hPa	860 - 1060

Ambient conditions during storage and transport			
Temperature		°C	-10 to +60
		°F	14 to 140
Relative humidity		%	10 - 75
Air pressure		hPa	860 - 1060

X-ray emitter			
Model			DG-07E22T2
Rated power		kW	1.6 (at 1 sec)
Type			Inverter
Tube voltage**		kV	60 - 99 (1 kV increment)
Tube current**		mA	4 - 16 (1 mA increment)
Duration of radiation exposure**		sec	1.9 - 13.4
Duty Cycle			1:60 or more (exposure time : interval duration)
Cooling			Automatic monitoring Shut-off at ≥ 60°C
Additional filters		mm Al	1.5
Permanent filtration (minimum)		mm Al	1.0
Total filtration (minimum)		mm Al	2.5
X-ray tube permanent filtration		mm Al	Minimum 0.8 (at 50 kV)
X-ray tube model			D-052SB / Canon
Focal spot size as per IEC 60336 X-ray tube		mm	0.5
Anode angle		°	5

*The reference axis is the perpendicular of the X-ray exit window at the level of the side marker for the focal point on the cover of the X-ray emitter

**Tube voltage/current range and exposure time depend on the type of exposure:

- Panorama (Voltage: 60 - 90 kVp, Current: 4 - 14 mA; Exposure time: 2.4 - 13.4 s)
- Remote X-ray (Voltage: 60 - 99 kVp, Current: 4 - 16 mA; Exposure time: 1.9 - 7.7 s)
- For further information, refer to sections "14 Default values", "15 Panoramic program parameters", and "16 Ceph program parameters"

Detector		Panorama	Ceph
Model		Xmaru1501CF-PLUS	Xmaru2602CF
Type		CMOS photodiode array	
Pixel size	µm	100	100 200 (2x2 binning)
Active surface area	mm	6 x 151.2	15.6 x 259.2
Frame rate	fps	~287	~ 109 ~ 330 (2x2 binning)
Gray scales	bit	14	14

Exposure Mode	FDD mm	FOD mm	ODD mm	Image capture scale (magnification factor)
Panorama	490.2	375.0	115.2	1.3
Ceph	1745	1524	221	1.14

FDD: distance from focal spot to detector

FOD: distance from focal spot to object

ODD: distance from object to detector (ODD = FDD - FOD)

Image capture scale = FDD/FOD

4.1 X-ray tube performance data

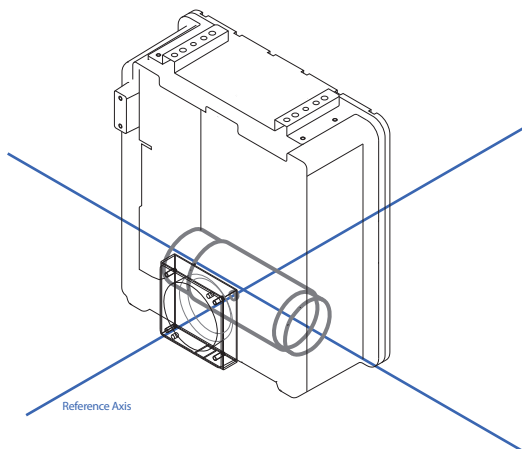

- Maximum deviation of the voltage peak from the displayed value $\pm 10\%$
- Maximum deviation of the tube current from the displayed value $\pm 20\%$
- Maximum deviation of the exposure time from the displayed value $\pm (5\% + 50\text{ ms})$
- The lowest possible load factor is obtained with a combination of the settings 60 kV und 4 mA.

Maximum Rating Charts

Constant Potential High-Voltage Generator
Nominal Focal Spot Value: 0.5x0.5

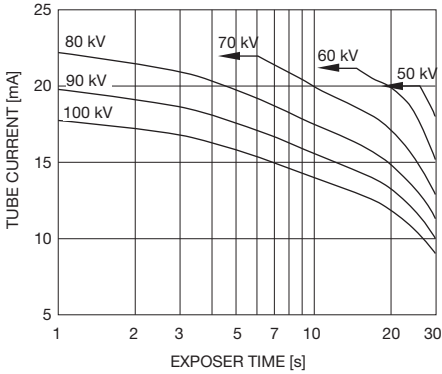

Emission and Filament Characteristics

Constant Potential High-Voltage Generator
Nominal Focal Spot Value: 0.5x0.5

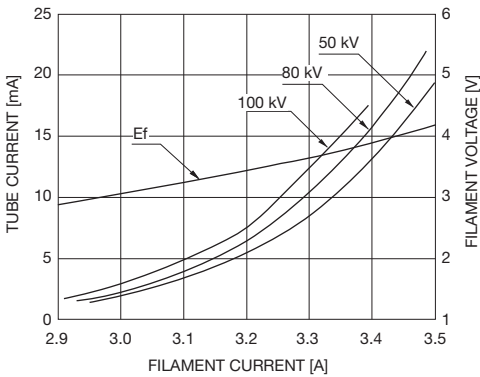

Anode Heating/Cooling Characteristics

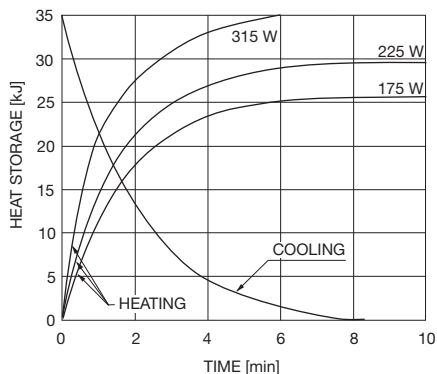

X-ray Housing Assembly Tube Characteristics

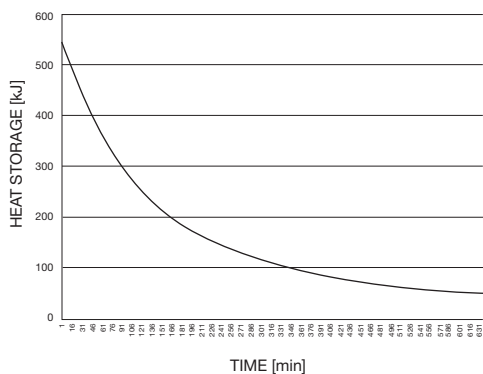

4.2 Electromagnetic compatibility (EMC)

Phenomenon Basic EMC standard or test procedure	Mode of operation	Tested connector	Test voltage	Test category / requirement
Interference voltage at the power supply connection CISPR 11:2015+A1:2016+A2:2019 EN 55011:2016/A11:2020	– Mode of operation – Standby	Voltage supply unit AC	220 V AC, 60 Hz 230 V AC, 50 Hz	CISPR11 Group 1, Class A
Electromagnetic interference radiation CISPR 11:2015+A1:2016+A2:2019 EN 55011:2016/A11:2020	– Mode of operation – Standby	Housing	220 V AC, 60 Hz 230 V AC, 50 Hz	CISPR11 Group 1, Class A
Emission of harmonics IEC 61000-3-2:2018+A1:2020 EN IEC 61000-3-2:2019/A1:2021	– Mode of operation – Standby	Voltage supply unit AC	230 V AC, 50 Hz	Class A

Phenomenon Basic EMC standard or test procedure	Mode of operation	Tested connector	Test voltage	Test category / requirement
Voltage changes, voltage fluctuations and emission of flicker IEC 61000-3-3:2013+A1:2017+A2:2021 EN 61000-3-3:2013+A1:2019	– Mode of operation – Standby	Voltage supply unit AC	230 V AC, 50 Hz	Pst: 1 PIt: 0.65 dmax: 4% dc: 3.3%
Immunity to interference, discharge of static electricity IEC 61000-4-2:2008 EN 61000-4-2:2009	– Mode of operation – Standby	Housing	– 220 V AC, 60 Hz – 230 V AC, 50 Hz	± 8 kV / contact ±2, ±4, ±8, ±15 kV/air
Immunity to interference, high-frequency electromagnetic fields IEC 61000-4-3:2020 EN IEC 61000-4-3:2020	– Mode of operation – Standby	Housing	– 220 V AC, 60 Hz – 230 V AC, 50 Hz	3 V/m 80 MHz–2.7 GHz 80% AM at 1 kHz
Immunity to interference by near fields of wireless RF communication devices IEC 61000-4-3:2020 EN IEC 61000-4-3:2020	– Mode of operation – Standby	Housing	– 220 V AC, 60 Hz – 230 V AC, 50 Hz	Table 9 in IEC 60601-1- 2
Immunity to interference by rapid transient bursts IEC 61000-4-4:2012 EN 61000-4-4:2012	– Mode of operation – Standby	Voltage supply cable AC Data cables	– 220 V AC, 60 Hz – 230 V AC, 50 Hz	AC current cable: ±2 kV Signal: ±1 kV 100 kHz repetition rate
Immunity to interference by surges IEC 61000-4-5:2014+A1:2017 EN 61000-4-5:2014+A1:2017	– Mode of operation – Standby	Voltage supply unit AC	– 220 V AC, 60 Hz – 230 V AC, 50 Hz	Line-vs-line: ±0.5 kV, ±1 kV Line to earth: ±0.5 kV, ±1 kV, ±2 kV
Immunity to interference by conducted disturbances induced by high-frequency fields IEC 61000-4-6:2013 EN 61000-4-6:2014	– Mode of operation – Standby	Voltage supply cable AC Data cables	– 220 V AC, 60 Hz – 230 V AC, 50 Hz	AC current and signal line: 3 V, 0.15 – 80 MHz 6 V ISM frequency bands Ranging from 0.15 MHz to 80 MHz : 80% AM at 1 kHz
Immunity to power frequency magnetic fields IEC 61000-4-8:2009 EN 61000-4-8:2010	– Mode of operation – Standby	Housing	– 220 V AC, 60 Hz – 230 V AC, 50 Hz	30 A/m 50 Hz & 60 Hz

Phenomenon Basic EMC standard or test procedure	Mode of operation	Tested connector	Test voltage	Test category / requirement
Immunity to interference by voltage dips IEC 61000-4-11:2020 EN IEC 61000-4-11:2020	– Mode of operation – Standby	Voltage supply unit AC	– 220 V AC, 60 Hz – 230 V AC, 50 Hz	0 % U_T ; 0.5 period at 0°, 45°, 90°, 135°, 180°, 225°, 270° and 315° 0 % U_T ; 1 period and 70% U_T ; 25/30 periods Single phase: at 0°
Immunity to short-term interruptions IEC 61000-4-11:2020 EN IEC 61000-4-11:2020	– Mode of operation – Standby	Voltage supply unit AC	– 220 V AC, 60 Hz – 230 V AC, 50 Hz	0% U_T ; 250/300 periods
Inference immunity in magnetic near field IEC 61000-4-39:2017 EN IEC 61000-4-39:2017	– Mode of operation – Standby	Housing	– 220 V AC, 60 Hz – 230 V AC, 50 Hz	134.2 kHz, 65 A/m 13.56 MHz, 7.5 A/m

The strength of the RF field that is fed into the network of the unit should be less than 3 V in the frequency range 0.15 to 80 MHz.

4.3 Dimensions

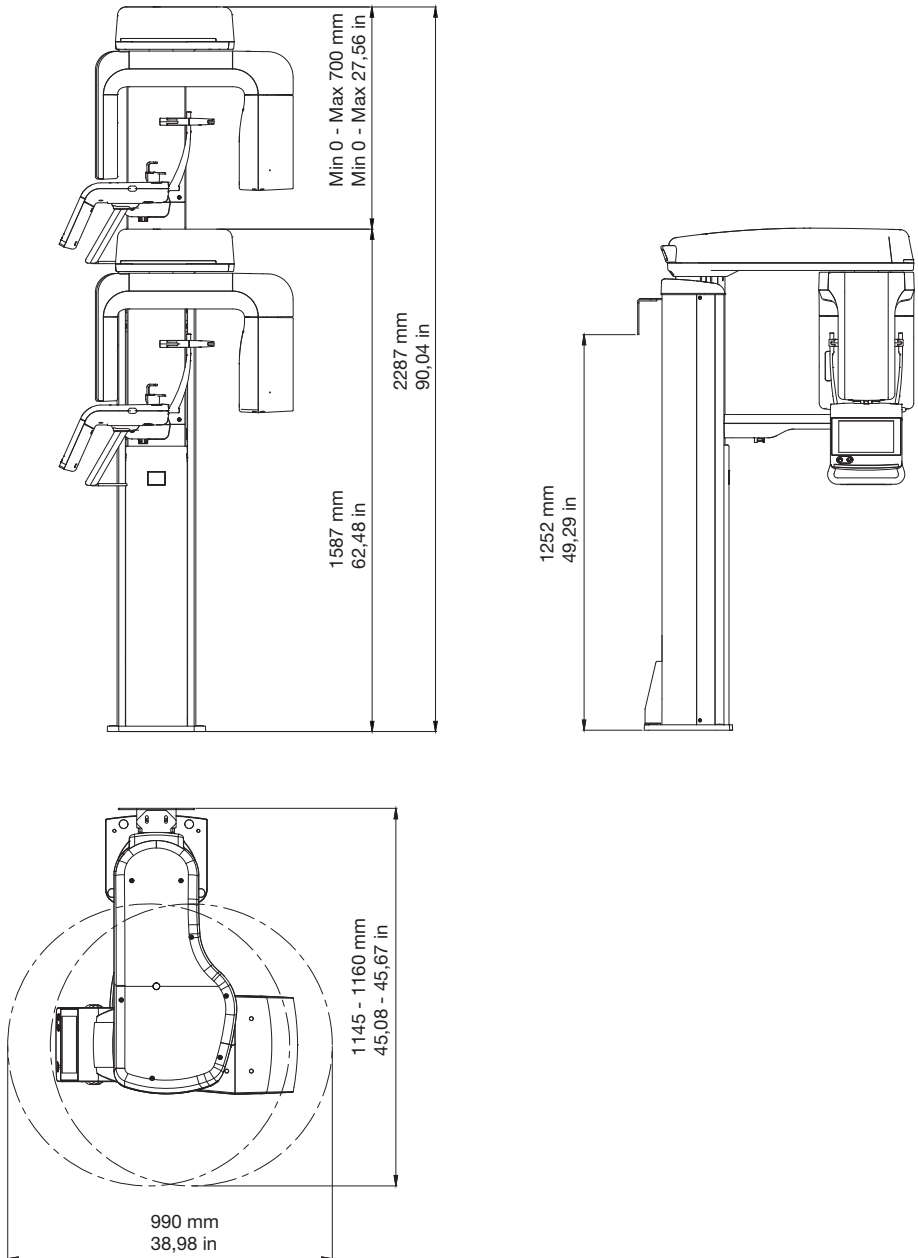

Fig. 3: VistaPano S 2.0

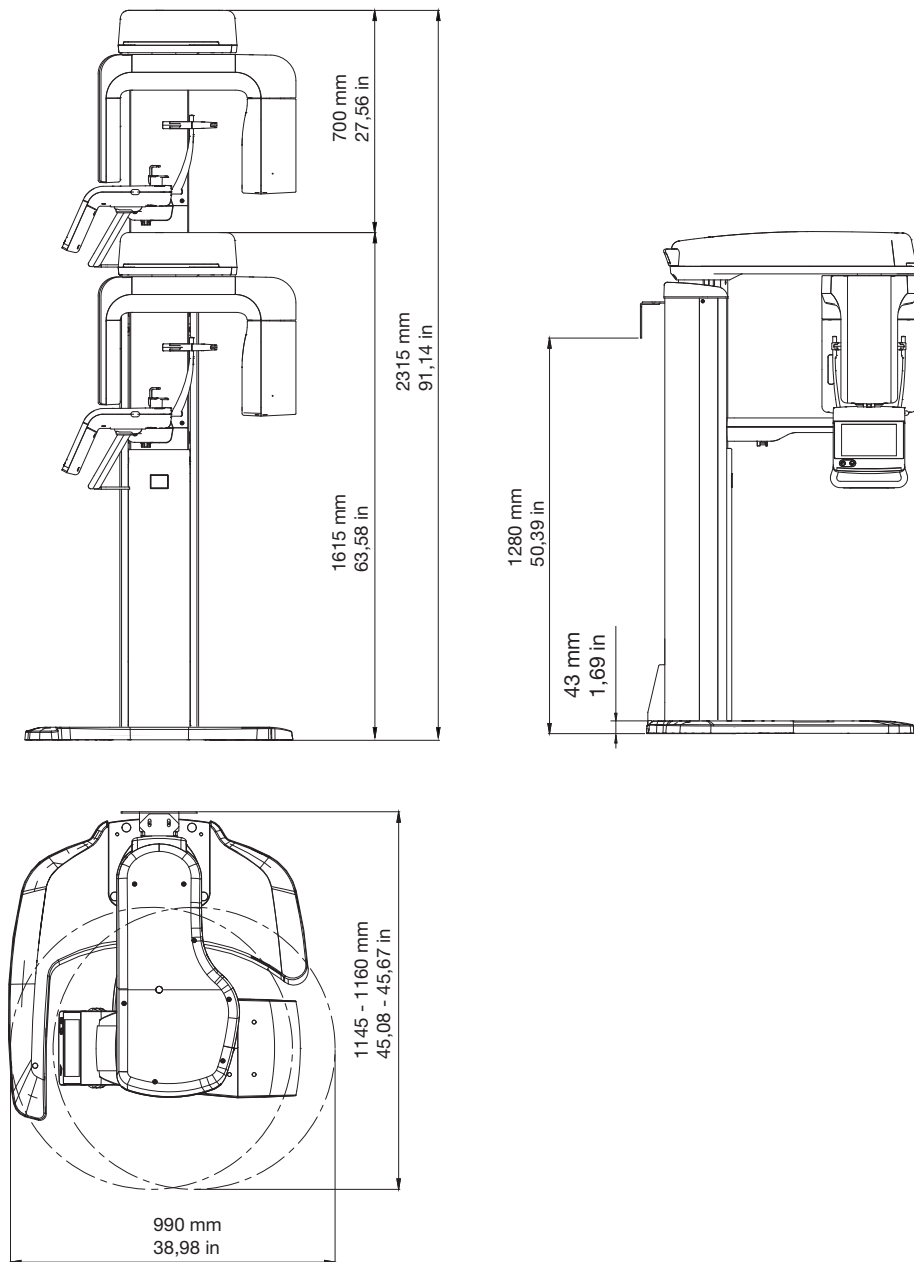

Fig. 4: VistaPano S 2.0 with floor stand

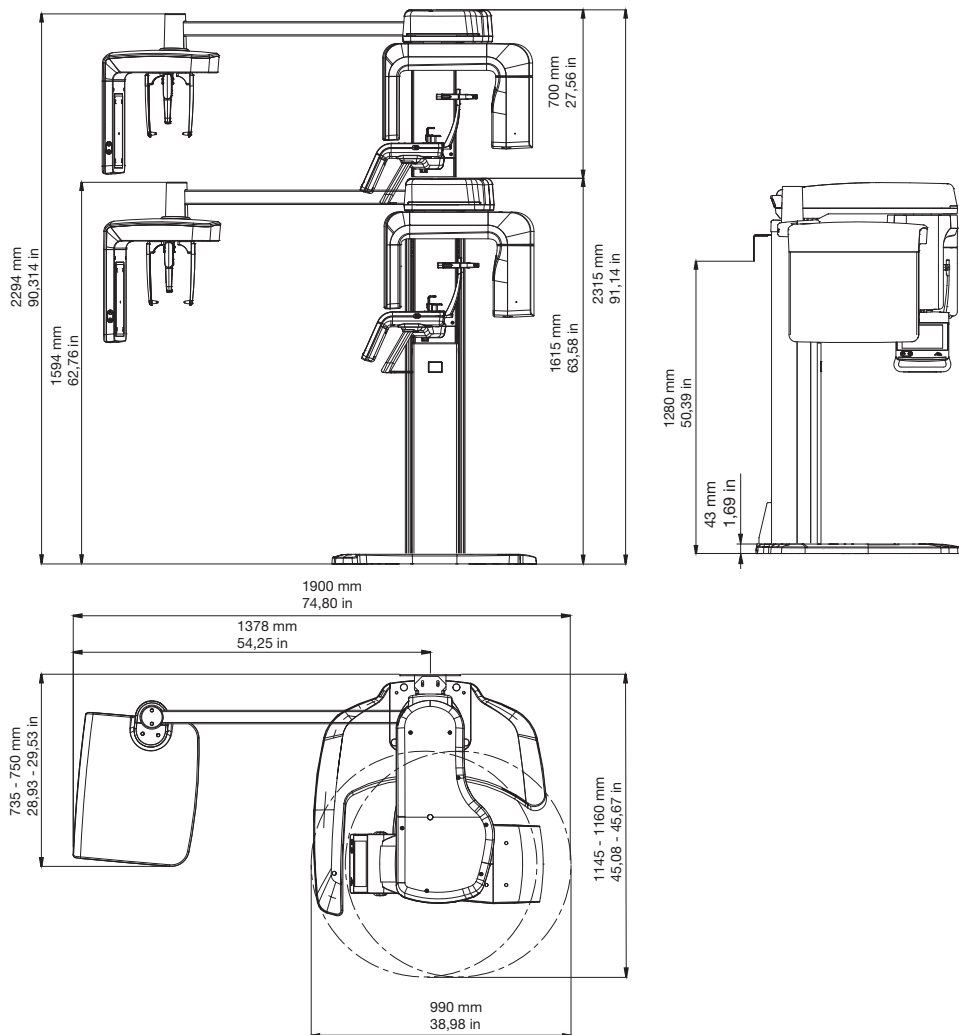
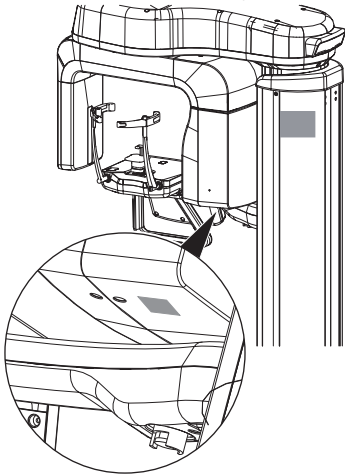

Fig. 6: VistaPano S Ceph 2.0 with floor stand

4.4 Model identification plate

The identification plates are located on the X-ray emitter and on the telescopic column.



4.5 Conformity assessment

This device has been subjected to conformity acceptance testing in accordance with the current relevant guidelines of the European Union. This equipment conforms to all relevant requirements.

5 Function

5.1 Panoramic X-ray device

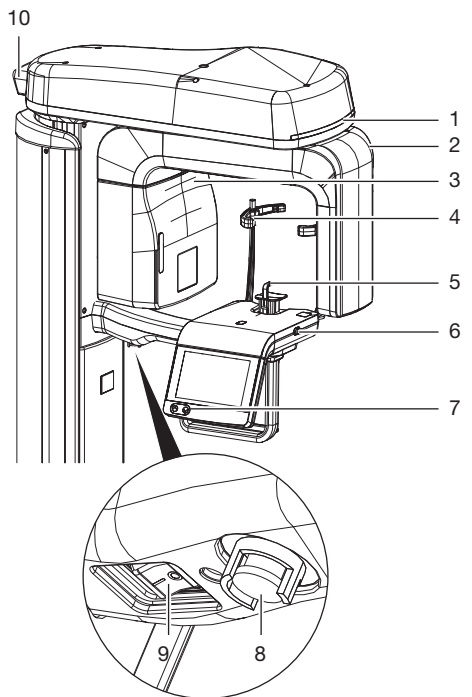

- 1 Status LED
- 2 C-shaped arm
- 3 X-ray tube
- 4 Head support with cushion
- 5 Chin holder and bite block
- 6 Lever for adjustment of the upper canine positioning beam
- 7 Buttons for height adjustment
- 8 EMERGENCY OFF button
- 9 On/off switch
- 10 Ambient Light

The panoramic X-ray unit is used to take digital panoramic images that enable diagnostics in the oral area.

The X-ray task is started via the imaging software and activated via the touch screen.

5.2 Cephalometric X-ray unit

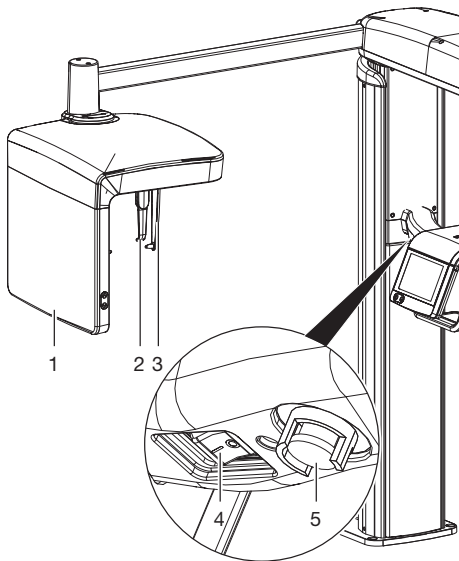

- 1 Sensor (Ceph)
- 2 Nose support
- 3 Ear rods with holder
- 4 On/off switch
- 5 EMERGENCY OFF button

The cephalometric unit digitally records the anatomy of the cranium.

The X-ray task is started via the imaging software and activated via the touch screen.

5.3 Operating elements

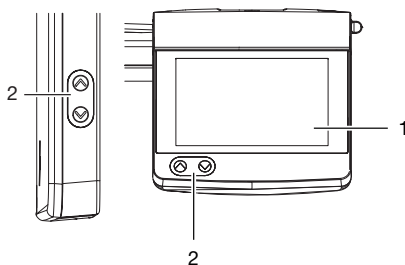

- 1 Touch screen
- 2 Buttons for height adjustment

The touch screen can be used to operate the unit, see also "6 Operating the touch screen".

Instructions can be entered on the touch screen with the tip of a finger.

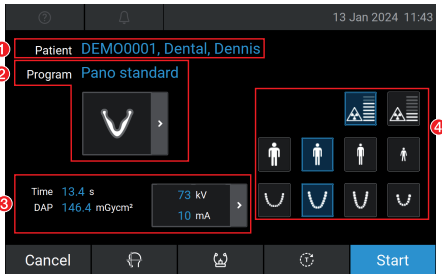
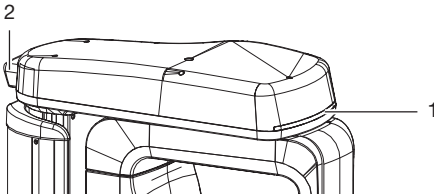

Fig. 7: Monitor, unit ready to acquire image

- 1 Logged-in patient
- 2 Selected X-ray image
- 3 Display of the X-ray parameters (duration, DAP value, voltage and current)
- 4 Selected parameters

The **Messages** button can be used to call up current messages.

5.4 Status LED



- 1 Status LED
- 2 Ambient Light

Mode of operation	Status LED	Ambient Light
Unit ready for operation	Blue	Blue can be customized, except red or white
Unit ready to acquire image X-ray confirmation required	Green	Green
X-ray image is generated	Yellow	Yellow

5.5 Positioning aids panoramic image

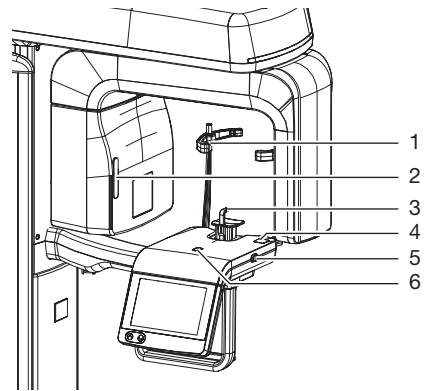

- 1 Head support with cushion
- 2 Frankfurt plane of the X-ray positioning beam
- 3 Positioning aid, e. g. chin support with bite block
- 4 Upper canine positioning beam
- 5 Lever for positioning the upper canine positioning beam
- 6 Mid-sagittal positioning beam

The positioning aids are used to correctly position the patient in the unit. The appropriate positioning aid is selected according to the selected image. The head supports gently keep the head of the patient in place.

Panorama

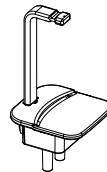

Bite block and adapter bite block



Comfort bite block incl. foam pad and bite block adapter

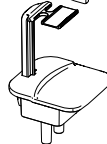

Chin support for edentulous jaws



Panorama

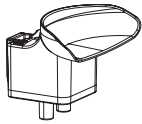

Chin rest, universal

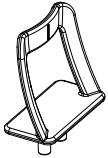

Chin rest for maxillary joint image

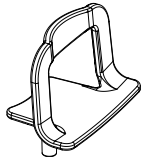

Chin rest for sinus image



Head supports with cushion

- 1 Sensor (Ceph)
- 2 Ear rods with holder
- 3 Nose support

Cephalometric projections

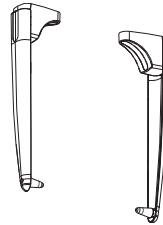

Ear rods with holder



Nose support

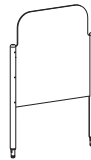

Carpus plate

5.6 Positioning aids for cephalometric projections

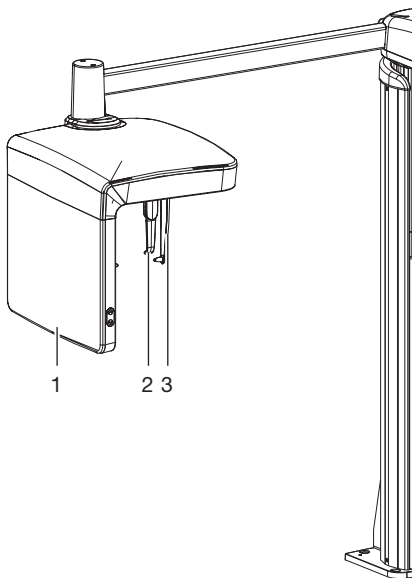

The applied parts in accordance with IEC 60601-1 are:

- Grips
- Head supports with cushion
- Positioning aids (e.g. bite block and mounting for bite block, chin support for edentulous patients)

The applied parts in accordance with IEC 60601-1 for the cephalometric unit are:

- Nose support
- Ear rods with holder
- Carpus plate

5.7 Exposure button

Exposure switch

The exposure switch is used to trigger the prepared image acquisition and start the X-ray exposure. The LED indicates the status of the unit, as does the LED on the unit.

- Green: unit ready for recording
- Yellow: X-ray beam active

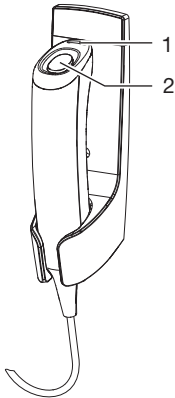

- 1 Indicator lamp (LED)
- 2 Exposure button

5.8 Sensor window

The active sensor surface is indicated by the markers in the corners of the sensor window. The cross indicates the geometric mid-point of the active sensor surface.

Panoramic X-ray device

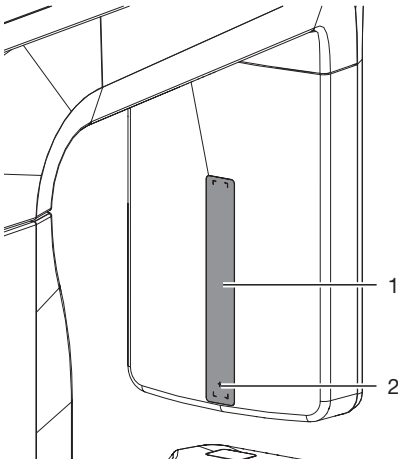

- 1 Active sensor surface
- 2 Geometric mid-point of the active sensor surface

Cephalometric X-ray unit

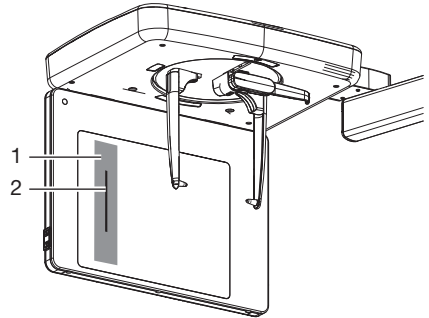

- 1 Line sensor housing
- 2 Active sensor surface

Usage

6 Operating the touch screen



NOTICE

Damage to the touch screen due to incorrect handling

- › Only touch the touch screen with your fingertips.
- › Do not use sharp objects (e.g. ball-point pen) to operate the touch screen.
- › Protect the touch screen from water.

1. Operate the touch screen by tapping it with a fingertip to select a button or input field.

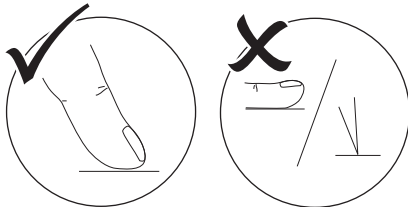

2. For further information about any window, tap on the *Help* field.

6.1 Navigating

If the contents of the window cannot be completely displayed on the touch screen, a scroll bar appears.



1. Tap or to move the displayed section of the window.

6.2 Using menus

The menus integrated in a window contain additional commands that can be selected.

1. To open the menu, tap .

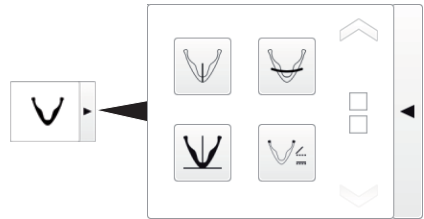

Fig. 8: Example: expanded menu

2. Select a command.

6.3 Calling up messages on the touch screen

The view on the touchscreen displays the current messages.

The *Messages* view at *Settings > Service menu > Messages* displays the history of all messages. A switch to the *Access level Technician* is required.

Messages are divided into the following categories:

	Fault	Unit will no longer function. When the error has been remedied, it may be necessary to acknowledge the error message.
	Notice	After acknowledgment the unit will continue to work, but only with limited functions.
	Note	Important information for the operator, e.g. about the current status of the device. The unit continues to operate.
	Information	Information for the operator. The unit continues to operate.
	Fault-free operation	

1. Tap .

This displays the message. If there are several messages, the most current with the highest priority is displayed first.

2. For more information about the message, tap .

7 Operation



In this section, the term "Child" is used for children and adolescents from the age of 7.



CAUTION

Health risks for the patient due to contraindications

- › Before using the unit on the patient, make sure that none of the listed contraindications are evident.

7.1 Operating the unit – a brief overview

- › Switching on
- › Selecting the patient / registering patient data
- › Selecting the image acquisition parameters
- › Positioning the patient on the device
- › Recording the X-ray image
- › Transferring and saving the image
- › Cleaning and disinfecting the unit

7.2 Switch the device on



CAUTION

Danger of injury by moving rotating unit arm

After the unit is switched on and the parameters are confirmed on the touch screen, the C-shaped angle connector piece is positioned. Persons can be injured during this.

- › Nobody may be present in the area of the rotating unit arm while the unit is being switched on.

1. Switch the device on.

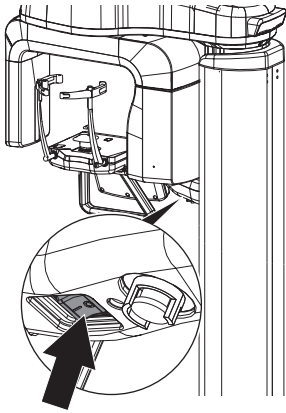

The LED on the unit flashes blue during the start-up process. Once the unit is ready for operation the LED on the unit lights up blue.



7.3 Making settings in the imaging software

The settings are described using the VistaSoft imaging software for an example. For further information regarding the use of the imaging software, refer to the relevant manual.

Preparing an X-ray image acquisition in VistaSoft

Requirements:

- ✓ VistaSoft has been opened.
- ✓ Patient is logged in.
- ✓ No other image acquisitions are in progress (X-ray or video).

1. In the menu bar, click on the required image (e.g.  for a standard panoramic image). Via  you can call up further acquisition types that belong to the grouping.

1. Depending on how the image acquisition types are configured, the acquisition of the X-ray image will start either immediately or you will first need to select an X-ray station.
2. If image acquisition does not begin automatically, select the X-ray station. The patient type, jaw arch, and imaging program parameters are pre-selected according to the patient.
3. Check the parameters (see also "Parameter overview").

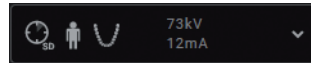

Click on Parameters to open the flyout for setting the parameters. The changed parameters are immediately synchronized with the device.

4. If the pre-selected parameters are correct, continue to work directly on the device.

Parameter overview





Patient type

The selection of patient type depends on the patient's size and/or head circumference. This means that the preset patient type may need to be changed, if necessary.

The X-ray parameters are preset using the patient type.

If a child is selected, then the X-ray parameters are different:

- Reduced dose
- Shorter circulation time
- Smaller radiation field

	Large, patient with large build
	Medium, patient with average build
	Small, patient with small build or adolescent
	Child (< 12 years of age)

Pano type

Multiple layers are recorded with the S-PAN technology. The optimum Pano recording is produced by selecting the sharpest layer for the horizontal and vertical image areas and then merging these image areas into a single image. S-PAN is preset.

S-PAN



S-PAN

PAN



PAN

Image quality



HD

HD images.
An improved signal/noise ratio is achieved via an extended exposure time. (Full Lat is not supported)



SD

SD images.
This setting is used for standard images.

Jaw arch

The selected jaw shape affects the rotational behavior of the C-shaped arm during image acquisition. This enables an image with an ideal layer position to be captured even on a particularly narrow or wide jaw.



Normal jaw arch



Narrow jaw arch



Wide jaw arch



Child's jaw arch

Acquisition program, adult

 The selection of the acquisition programs depends on the image acquisition device.

For panoramic images of children, the size of the radiation field is reduced with the aid of an additional collimator. The radiation dose is significantly reduced for this image.

Panoramic images



Standard

The standard panoramic image records the complete dental area with ascending dental branches and jaw joints.



Front

The image shows a reduced dental area without ascending dental branches.

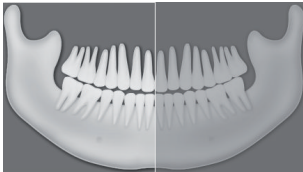

Right

The image only shows the right dental area.

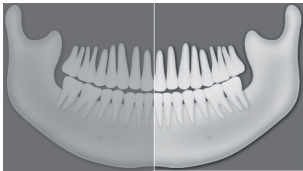

Left

The image only shows the left dental area.



Orthogonal

The image shows the complete dental area and is generated perpendicular to the maxillary arch. This prevents overlapping crowns.

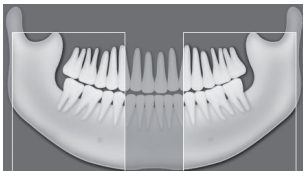

Bitewing

The image shows the lateral dental area with a size limited to the bite wings.

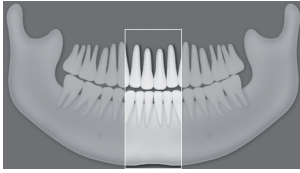
Panoramic images**Bite wing front**

The image shows the anterior dental area with a size limited to the bite wings.

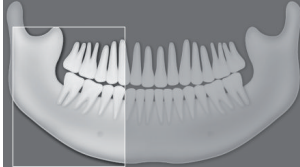
**Bite wing right**

The image shows the right posterior region with a size limited to the bite wings.

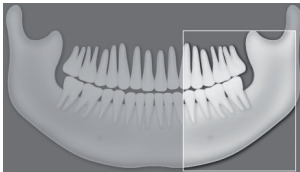
**Bite wing left**

The image shows the left posterior region with a size limited to the bite wings.

Temporomandibular imaging**Maxillary joint, lateral**

The image shows the lateral maxillary joints for an open and closed mouth in 4-fold depiction in one image.

**Maxillary joint, PA**

The image shows the posterior-anterior maxillary joints for an open and closed mouth in 4-fold depiction in one image.

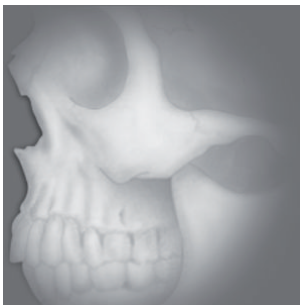
Sinus images**Sinus, lateral**

The X-ray image shows the lateral sinuses.

Sinus images



Sinus, PA

The X-ray image shows the posterior-anterior sinuses.

Cephalometric exposures



Head Lateral Full format

The X-ray image shows the entire head of the patient in a lateral view.

This image recording program can be selected in some versions.



Head Lateral

The X-ray image shows the facial skull of the patient in a lateral view.

This image recording program can be selected in some versions.



Head PA

The image shows the posterior/anterior cranium.

It is suitable for semi-axial cranial images and provides a cranial eccentric overview.

Cephalometric exposures**SMV**

The image shows the cranium in a submentover-ter projection. It is suitable for recording the jaw arch and the jaw joints, for example.

**Waters View**

This view is suitable for recording the articular head in the mandibular joint socket, for example.

**Carpus**

The image shows the carpus of the patient. It is suitable for providing conclusions on the growth stage of the body/jaw.

Acquisition program, child

For panoramic images of children, the size of the radiation field is reduced with the aid of an additional collimator. The radiation dose is significantly reduced for this image.

Panoramic images

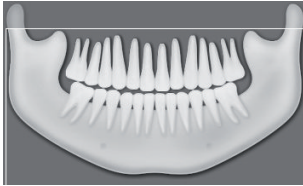

Standard

The standard panoramic image records the complete dental area with ascending dental branches and jaw joints.



Front

The image shows a reduced dental area without ascending dental branches.

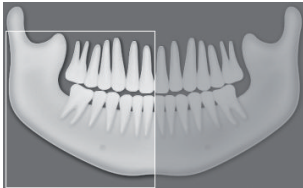

Right

The image only shows the right dental area.

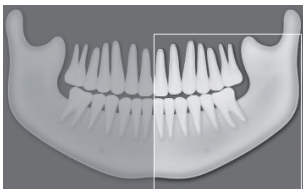

Left

The image only shows the left dental area.

7.4 Panoramic X-ray device

For the acquisition of the X-ray image, the patient is positioned in the unit using the corresponding positioning aids and then accurately aligned using the positioning beams.



WARNING

Danger due to non-processed products

Risk of infection for operator and patient

- › Reprocess the product correctly and sterilize it as required prior to the first use and after every subsequent use.
- › Do not reprocess disposable items.

Inserting the positioning aids

Inserting the head supports

If no head supports are inserted or if they are dirty, insert new head supports before positioning the patient.

1. Remove any dirty head supports by pulling them out.
2. Insert new head supports. When doing this, make sure that the cushions of the head supports face inwards.

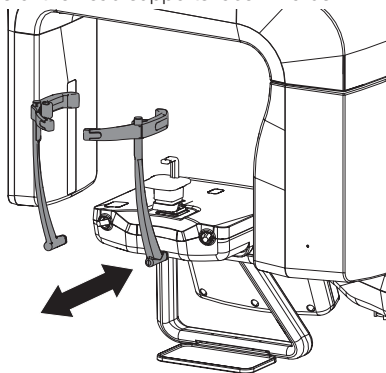

Inserting the cushions of the head supports

If no cushions are inserted in the head supports or if they are dirty, insert new cushions before you position the patient.

1. Remove any dirty cushions by pulling them out.

2. Inserting the cushion holder.

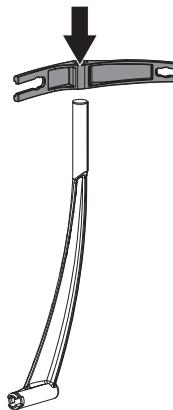

3. Insert new cushions in the cutout provided on the head supports.

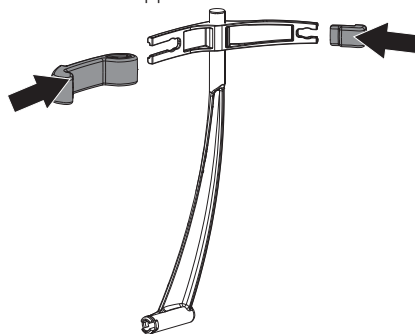

Inserting the positioning aid for panoramic images

We recommend using the mounting for the bite block and the bite block or Comfort bite block for panoramic images.

In the case of edentulous patients, the chin support for edentulous jaws can be used.

The other positioning aids can also be used, depending on the application scenario.

1. Inserting the holder for bite block.

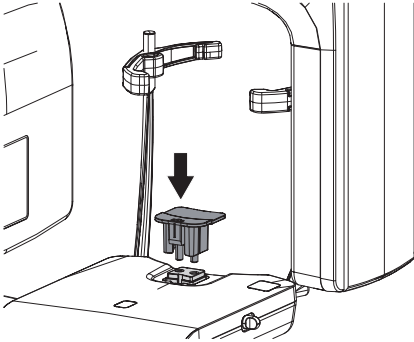

The bite block can be used with or without a hygienic protective cover. We recommend using the bite block with a hygienic protective cover.

If the bite block is to be used without a hygienic protective cover, please refer to the reprocessing instructions "9 Reprocessing".



If the bite block is to be used with the foam pad, please refer to the reprocessing instructions "9 Reprocessing".



WARNING

There is a danger of cross contamination if hygienic protective covers are not used or if they are re-used

- › Reprocess the bite block after using it without the hygienic protective cover.
- › Do not re-use the hygienic protective cover (disposable item).



WARNING

There is a risk of cross contamination when the light protection cover is not used or when the light protection cover is re-used

- › Reprocess the Comfort bite block after using it without the foam pad.
- › Do not re-use the light protection cover (disposable item).



WARNING

Danger from the re-use of products intended for single use

Single-use article is damaged after use and cannot be reused.

- › Dispose of single-use articles after use.

2. Optionally, insert the bite block or Comfort bite block with foam pad.

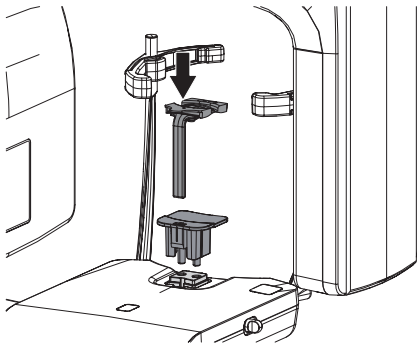
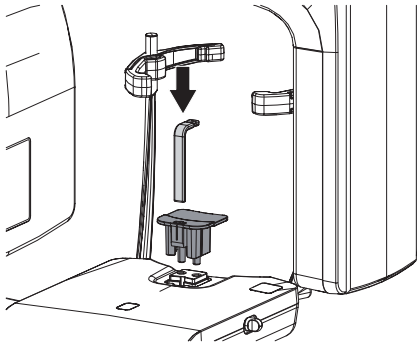

Inserting the positioning aid for panoramic images with hygienic protective cover (optional)



WARNING

Risk of cross contamination due to non-reprocessed bite block

- › Reprocess the bite block in accordance with the reprocessing instructions.

1. Optionally place a hygienic protective cover over the bite block.

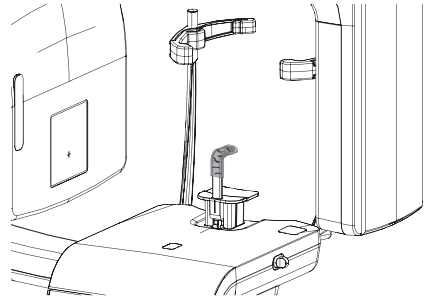

3. In the case of edentulous patients, the chin support for edentulous jaws can be used.

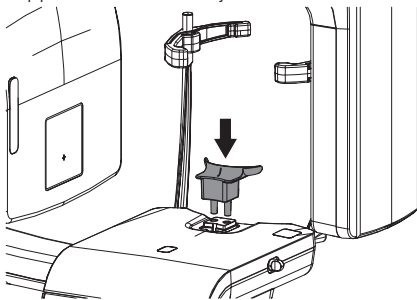

Inserting the positioning aid for the maxillary joint image

Correct image acquisition is only possible with the chin support for maxillary joint images.

1. Inserting the chin support for the maxillary joint image.

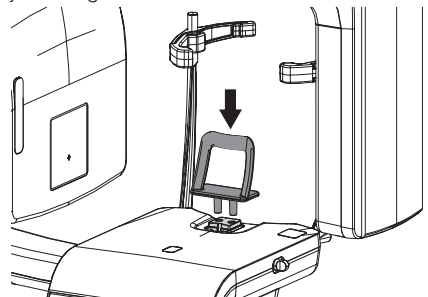

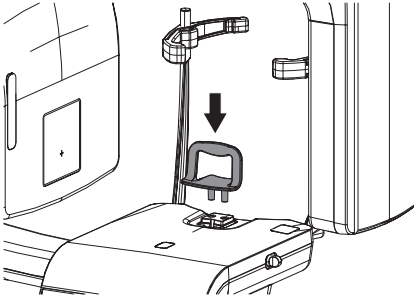

Inserting the positioning aid for sinus images

1. Inserting the chin support for sinus images.

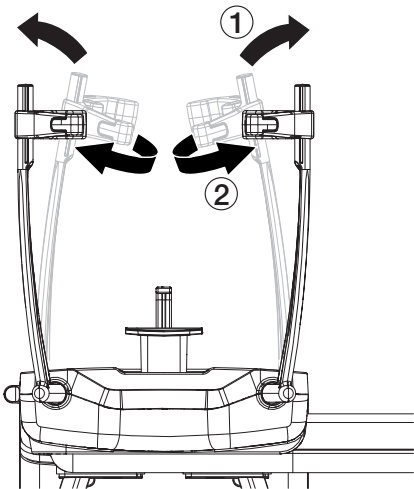

Opening the head supports



1. Open the head supports by pressing the  button on the touch screen.
2. Open the cushion holder with cushions properly such that the patient can be positioned.

7.5 Positioning the patient

For the X-ray image, the patient is accurately aligned using the positioning beams.

Requirements:

- ✓ The patient has taken off jewelry and metal objects, e.g. earrings, hair slides, glasses, artificial dentures or orthodontic aids.
- ✓ The patient has put on a protective lead apron.
- ✓ The patient has been informed about the recording of the X-ray image.
- ✓ The patient has been informed that the unit may pass by close to his/her head (including through the field of vision). If patients feel uncomfortable with this, he or she can close his/her eyes while the image is being taken.
- ✓ The patient has been informed that he/she can press the emergency stop switch in the event of anxiety during image acquisition.
- ✓ The patient has been informed that he/she has to place his/her tongue against the roof of the mouth during the X-ray.
- ✓ The patient has been informed that he/she has to keep his/her eyes closed during positioning of the X-ray positioning beam.
- ✓ The patient has been told not to move while the X-ray is being taken until the unit is back in the starting position.



CAUTION

Danger of injury by moving rotating unit arm

After the unit is switched on and the parameters are confirmed on the touch screen, the C-shaped angle connector piece is positioned. Persons can be injured during this.

- › Nobody may be present in the area of the rotating unit arm while the unit is being switched on.

1. Move the patient into an upright position at the unit.
It is also possible to position patients in a seated position (e.g. wheelchair users, tall patients).

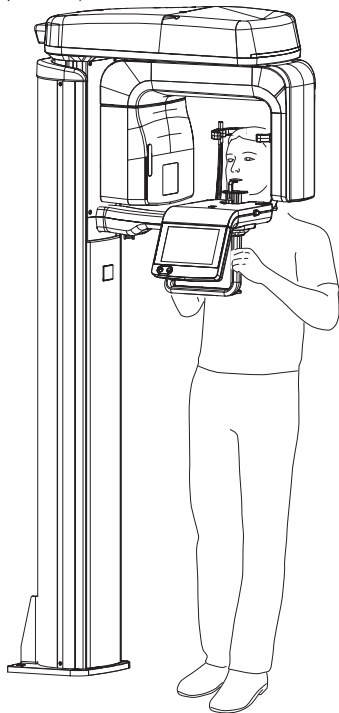

2. Use the   buttons to set the height level of the unit.

Panoramic image acquisition

1. The patient bites onto the bite block, with the upper and lower incisors resting in the grooves provided.

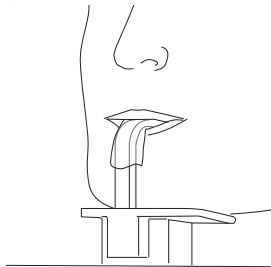

2. Use the chin support for edentulous patients in the case of patients who do not have any teeth. Here, the patient places his/her chin on the chin support.

Jaw image open / closed

1. Position the patient with the upper lip against the chin support.



Sinus image acquisition

1. Position the patient so that his/her bottom lip presses lightly against the chin support.

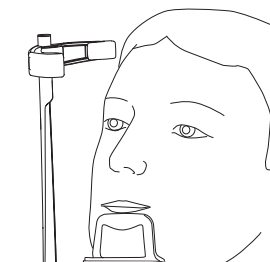

Adjusting the position with the positioning beams



WARNING



Risk of blinding from laser beam

- › Do not allow the laser beam to project directly into the eye of the patient.
- › Activate the X-ray positioning beam only after the patient has closed his/her eyes.



The alignment of the upper canine X-ray positioning beam is crucial for image quality.

1. Check to make sure that the patient has closed his/her eyes.
2. If necessary, correct the height of the unit again.
3. Activate the positioning beams on the touch screen by tapping on .

- Align the head of the patient according to the Frankfurt horizontal plane with the aid of the X-ray positioning beam.
Exception: sinus image. Patient over-extends the cervical vertebral column to the rear by approx. 10° to 15°. Set the laser level to the lower margin of the eye by tapping and holding  or .

- For a sinus image:**
Patient over-extends the cervical vertebral column by approx. 10° to 15°.

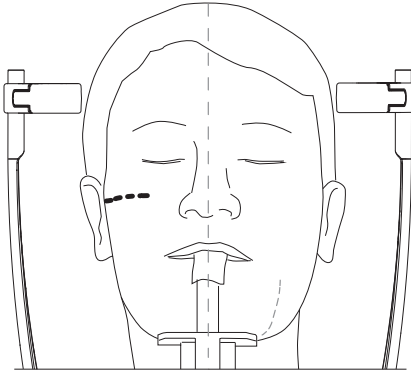

- Check the X-ray positioning beam for the mid-sagittal plane and correct it if necessary.

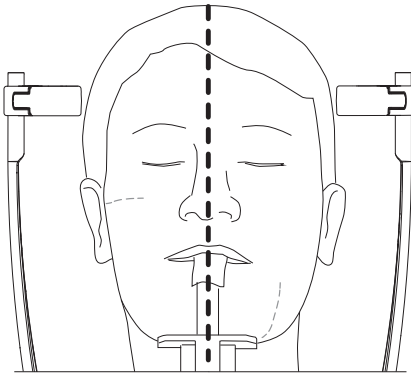

- Have the patient smile so the upper canine is visible.
Direct the "upper canine" X-ray positioning beam as exactly as possible to the middle of the upper canine.

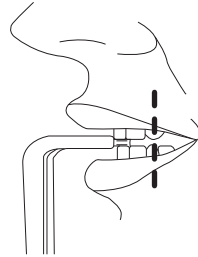

- If necessary, correct the X-ray positioning beam manually.

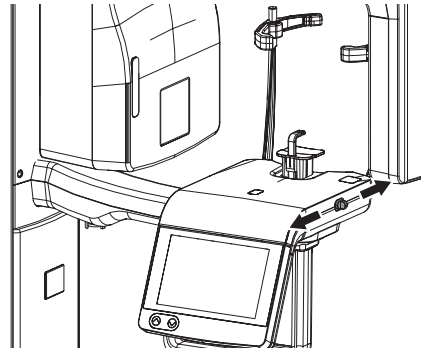



The patient is correctly positioned using the X-ray positioning beams.

- Deactivate the positioning beams on the touch screen by tapping on .

Adjusting the head supports

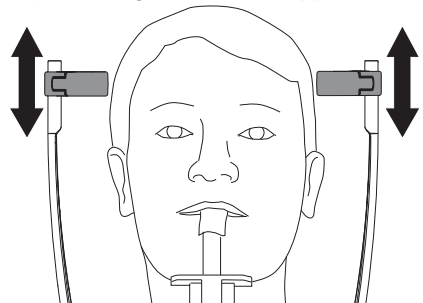
- Adjust the height of the head supports.



- Carefully press the head supports by hand towards the head in order to check if they are in the right position. The device or the head supports are not damaged in the process. Ideally, the head supports should make contact slightly above the eye brows; correct the position as required.
- Close the head supports with the  button. To do this, just press the button briefly – don't press and hold.

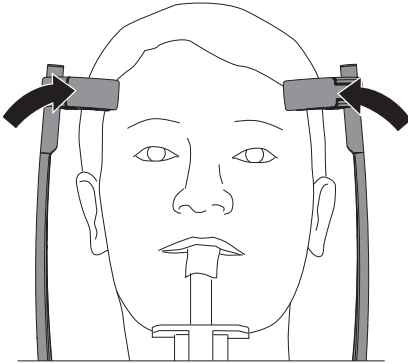

The head supports automatically touch against the head of the patient at a defined pressure.

7.6 Cephalometric exposure

Setting up the unit

- Disinfect the positioning aids, see "8 Cleaning and disinfection".
- Fit the ear rods with protective caps and the nose support with a protective cover.

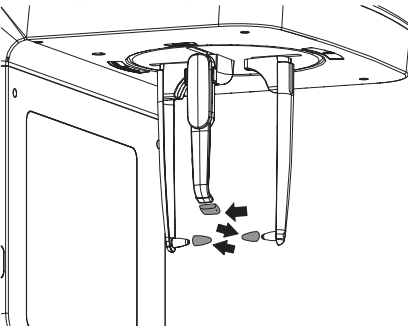

- Grasp the holder for the ear rods at the top and push outwards.

- Swivel the nose support to the side.

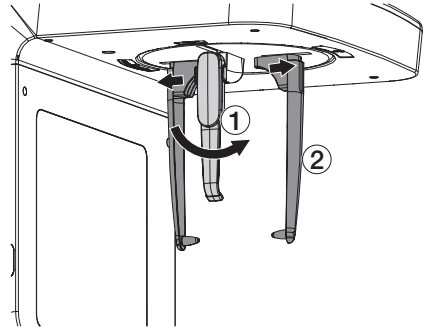

- Use the   buttons to set the unit to the height of the patient.

Positioning the patient

For recording of the X-ray image, the patient is positioned in the unit using the relevant positioning aids. The patient must not move while the image is being taken.

Requirements:

- ✓ The patient has taken off jewelry and metal objects, e.g. earrings, hair slides, glasses, artificial dentures or orthodontic aids.
- ✓ The patient has put on a protective lead apron.
- ✓ The patient has been informed about the recording of the X-ray image.
- ✓ The patient has been told not to move while the X-ray is being taken until the unit is back in the starting position.

- Use the   buttons to set the unit to the height of the patient.

Preparations for the head PA image

- ✓ The holders for the ear rods are pushed apart.
- ✓ The nose support is swiveled upwards.
- ✓ The holders for the ear rods are rotated by 90° toward the sensor.
- ✓ The ear rods are fitted with protective caps and the nose support is fitted with a protective cover.
- ✓ The unit is adjusted to the height of the patient



WARNING

Risk of injury when positioning the ear rods

If the ear rods are positioned with jerky movements on the patient, there is a risk that the patient's eardrum will be damaged.

- Grasp the ear rod holder at the top with both hands and gently squeeze it together until it is placed in the patient's auditory canal.

1. Place the patient vertical with his/her face towards the sensor. The Frankfurt plane of the patient is parallel to the floor.

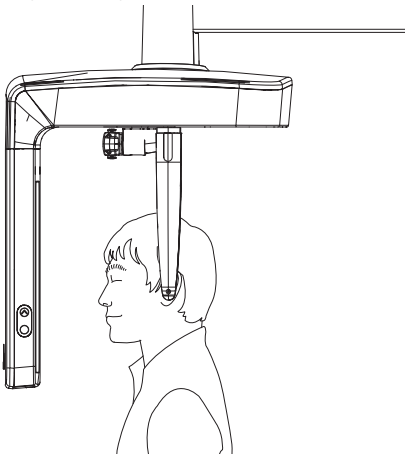

2. Adjust the holders for the ear rods to the height of the external auditory canals of the patient.

Preparations for the lateral head image

- ✓ The holders for the ear rods are pushed apart.
- ✓ The nose support is swiveled upwards.
- ✓ The holders for the ear rods are in a line with the sensor.
- ✓ The ear rods are fitted with protective caps and the nose support is fitted with a protective cover.
- ✓ The unit is adjusted to the height of the patient

1. Place the patient with his/her face towards the nose support. The Frankfurt plane of the patient is parallel to the floor.

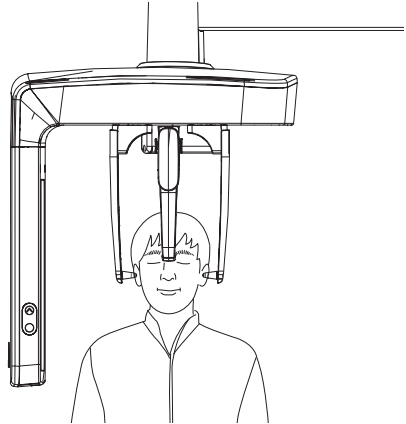

WARNING

Risk of injury when positioning the ear rods

If the ear rods are positioned with jerky movements on the patient, there is a risk that the patient's eardrum will be damaged.

- Grasp the ear rod holder at the top with both hands and gently squeeze it together until it is placed in the patient's auditory canal.

2. Adjust the holders for the ear rods to the height of the external auditory canals of the patient.
3. Position the nose support at the height of the nasal bridge.

Preparations for the SMV image

- ✓ The holders for the ear rods are pushed apart.
- ✓ The nose support is swiveled upwards.
- ✓ The holders for the ear rods are rotated by 90° toward the sensor.
- ✓ The ear rods are fitted with protective caps.
- ✓ The unit is adjusted to the height of the patient

1. Place the patient upright with the back of his/her head towards the sensor.
2. Instruct the patient to tilt his/her head backwards.

**WARNING****Risk of injury when positioning the ear rods**

If the ear rods are positioned with jerky movements on the patient, there is a risk that the patient's eardrum will be damaged.

- Grasp the ear rod holder at the top with both hands and gently squeeze it together until it is placed in the patient's auditory canal.

3. Adjust the holders for the ear rods to the height of the external auditory canals of the patient.

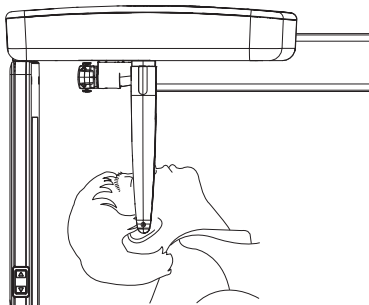
**Preparations for the Waters View image**

- ✓ The holders for the ear rods are pushed apart.
- ✓ The nose support is swiveled upwards.
- ✓ The holders for the ear rods are rotated by 90° toward the sensor.
- ✓ The ear rods are fitted with protective caps.
- ✓ The unit is adjusted to the height of the patient

1. Place the patient vertical with his/her face towards the sensor.
2. Instruct the patient to tilt his/her head backwards.

**WARNING****Risk of injury when positioning the ear rods**

If the ear rods are positioned with jerky movements on the patient, there is a risk that the patient's eardrum will be damaged.

- Grasp the ear rod holder at the top with both hands and gently squeeze it together until it is placed in the patient's auditory canal.

3. Adjust the holders for the ear rods to the height of the external auditory canals of the patient.

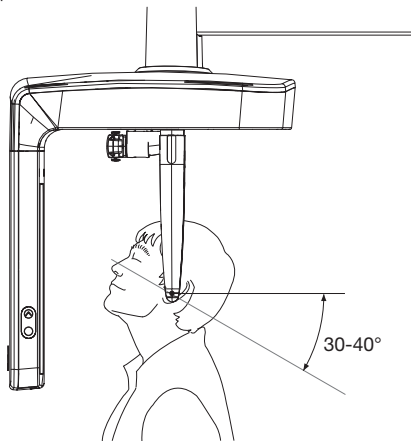
**Preparations for the carpus image**

- ✓ The holders for the ear rods are pushed apart.
- ✓ The holders for the ear rods are rotated by 90° toward the sensor.

1. Insert the carpus plate into the holes provided until it clicks into place.

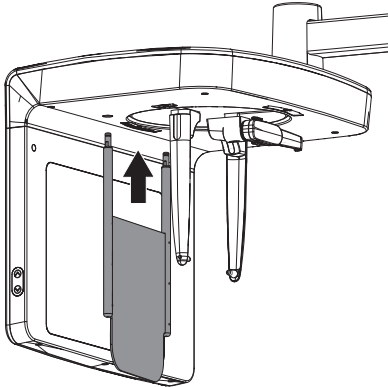

2. Place the patient sideways to the unit.
3. Adjust the height of the unit so the patient can lay his/her hand on the carpus plate with the arm bent.
4. The patient lays his/her right hand on the carpus plate with the fingers outstretched.

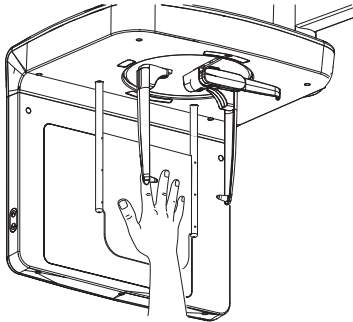

1. Tap and hold **Test run** on the touch screen. While doing this, constantly monitor the movements of the unit. If the unit is obstructed in its movements, release the **Test run** button. The unit stops immediately. Reposition the patient.
2. Tap on **Start position** to perform the return run.

7.7 Start a test run

The test run ensures that the unit can perform the image acquisition without any problems. This prevents unnecessary exposure of the patient to radiation.

 No radiation is generated during the test run.

Requirements:

- ✓ The patient is correctly positioned in the unit using the positioning aids and the positioning beams.
- ✓ The required imaging program has been selected.

7.8 Taking the X-ray image



CAUTION

Injuries due to X-rays

- X-rays can cause tissue damage.
- › Comply with the radiation protection regulations.
- › Maintain the minimum distance.



CAUTION

Danger of excessively high radiation dose

- › Before an image acquisition is triggered, all data entered on the PC must be checked on the touch screen.



NOTICE

Damage to the X-ray tube due to overheating

- › Continuous operation without sufficient cooling can lead to overheating.
- › Allow the X-ray tubes to cool sufficiently.

1. Check all parameters on the touch screen and change them if necessary. The changed parameters are immediately synchronized with the imaging software. The parameters can then no longer be changed in the imaging software.
2. Remind the patient to press his/her tongue against the roof of the mouth during image acquisition.

3. Press **Start** to confirm the parameters.

The C-shaped arm is being positioned. The LED on the exposure switch and the status LED on the unit light up green. The touch screen displays that the unit is ready to take an image.

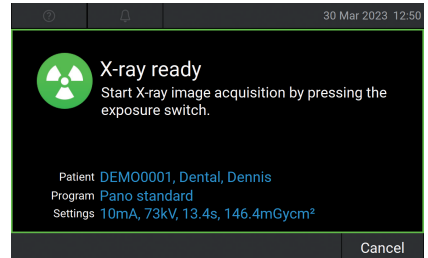

4. Trigger the image by pressing and holding the button on the exposure switch until the acoustic signal stops and the control lamp goes out. The scan times depend on the patient type, recording program and image quality (see "Appendix").

Image acquisition is started. During the acquisition, the LED on the exposure switch and on the unit illuminates yellow. An acoustic signal is issued.



If the button on the exposure switch is released before the control lamp goes out or the emergency stop switch is pressed (e.g. if there is a danger to the patient or to anyone else in the area), the ongoing image acquisition is aborted. The X-ray image will be unusable as a result and should be retaken as required. In this case, the operators must use their skills and training to decide on the risks of a repeated image acquisition.

In addition, an error messages appears on the touch screen.

While an X-ray is being taken, this is indicated on the touch screen by:

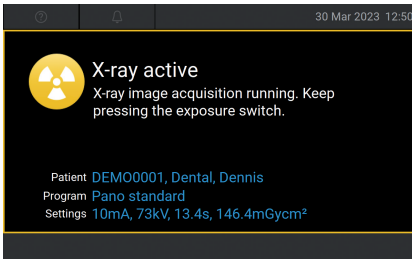

After the acquisition of maxillary joint images, it is necessary to confirm a message on the touch screen and trigger a second image acquisition. The images are then combined into a single image.

The LED on the unit lights up blue when the X-ray acquisition has been completed. The C-shaped arm does not automatically move back to the starting position after the trigger button is released.

5. Click **OK** to confirm the message.

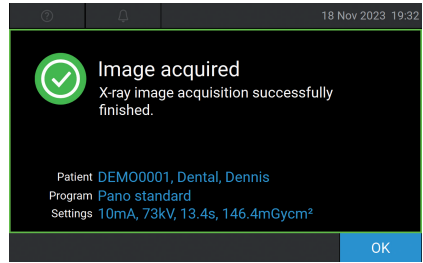

6. Release the head supports. The patient can leave the X-ray room.
7. Remove the hygienic protective cover.
8. Remove and disinfect the positioning aids.
9. The unit can be returned to its starting position by touching **Start**. Otherwise, the C-shaped arm is positioned via the imaging software during adjustment of the parameters.
10. Allow the X-ray tube to cool before starting the next X-ray image. Continuous operation without cooling times can lead to overloading.



If the temperature of the X-ray head exceeds 60°C, X-ray imaging is stopped and an error message is displayed in the imaging software. The unit will resume operation as soon as the temperature of the X-ray head has cooled to 58°C.

7.9 EMERGENCY OFF

The EMERGENCY OFF button stops the unit and switches it off. It can be used if the unit is taking an X-ray even though the exposure button is no

longer being pressed, or if the patient is injured or the unit is damaged.

1. Press the EMERGENCY OFF button.

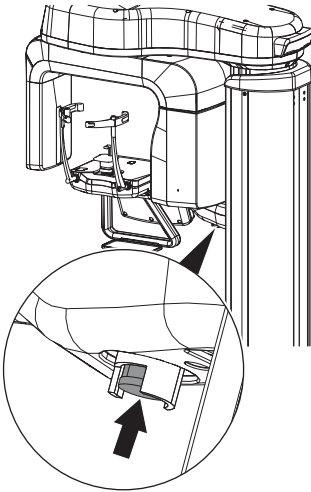

Device is switched off.

Release the EMERGENCY OFF button

You need to release the EMERGENCY OFF button before you can restart the unit.

1. Twist the EMERGENCY OFF switch to release it.

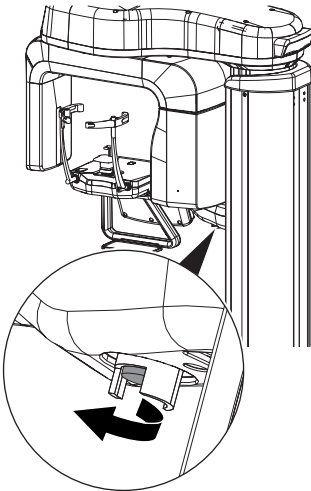

2. Switch the unit back on again.

8 Cleaning and disinfection



NOTICE

The use of unsuitable agents and methods can damage the unit and accessories

- › Only use the disinfection and cleaning agents specified or approved by Air Techniques and the EPA.
- › Comply with the operating instructions of the disinfectants and cleaning agents.



Wear hand protection.



Prior to working on the unit or in case of danger, disconnect it from the mains power.

The following cleansers and disinfection agents have been tested for the compatibility of materials:

- Birex wipes
- Discide Ultra Towelettes
- Opti Cide 3 surface wipes
- Optim 33TB wipes
- Maxiwipe germicidal cloth
- Cavi Wipes
- Cavi Wipes 1
- PDI Sani-Cloth
- Clorox
- Monarch

8.1 Surface of the unit



NOTICE

Damage to the touch screen caused by cleaning it with disinfectant

- › Only clean the touch screen with a soft cloth and a commercially available cleaning agent.

The surface of the unit must be cleaned and disinfected if it is contaminated or soiled.



NOTICE

Liquid can cause damage to the unit

- › Do not spray the unit with cleaning agents or disinfectants.
- › Make sure that no liquid penetrates into the unit.

1. Remove any soiling with a soft, damp, lint-free cloth.
2. Disinfect the surfaces with a disinfection wipe. Alternatively, use a quick-acting surface disinfectant on a soft, lint-free cloth. Comply with the operating instructions of the disinfectant.

8.2 Positioning aids

The positioning aids must be cleaned and disinfected if they are contaminated or soiled.

Head supports with cushion

1. Pull the head supports off the device.
2. Remove the cushions from the head supports.

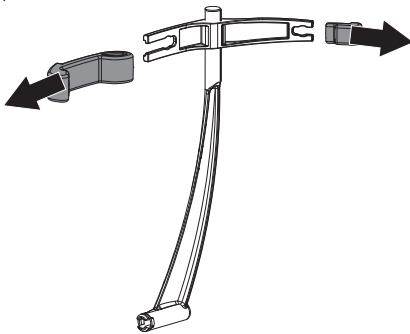

3. Remove the cushion holder.



4. Remove any soiling with a soft, damp, lint-free cloth.
5. Disinfect the surfaces using a disinfection wipe. Alternatively, use a quick-acting surface disinfectant on a soft, lint-free cloth. Comply with the operating instructions of the disinfectant.
6. Reprocessing the cushions (see "9 Reprocessing").

Chin support, chin holder and bite block holder

1. Pull the chin support, chin holder or bite block holder off the device.
2. Remove any soiling with a soft, damp, lint-free cloth.
3. Disinfect the surfaces using a disinfection wipe. Alternatively, use a quick-acting surface disinfectant on a soft, lint-free cloth. Comply with the operating instructions of the disinfectant.

9 Reprocessing

The following accessories need to be reprocessed:

- **Bite block, Bite block holder**
 - Manual cleaning
 - Automatic cleaning and disinfection
 - Steam sterilization
- **Chin holder for mandibular joint image, chin holder for edentulous jaws, and chin holder for sinus image**
 - Manual cleaning
 - Automatic cleaning and disinfection
- **Cushion for head supports Plus**
 - Manual cleaning
 - Automatic cleaning and disinfection

In order to prevent damage to the accessories, only the methods described above must be used.

9.1 Risk analysis and classification

A risk analysis and classification of medical devices that are common in dentistry must be performed before they are reprocessed by the operator. Comply with all national directives, standards and specifications such as e.g. the "Guidelines for Infection Control in Dental Health-Care Settings from the Centers for Disease Control and Prevention".

Accessories of the medical device are also subject to reprocessing.

Recommended classification

Recommended classification given proper use of the bite block:

- **semi-critical**

Recommended classification given proper use for the bite block holder, chin holder for mandibular joint image, chin holder for edentulous jaws, and chin holder for sinus image and cushions for head supports Plus:

non-critical

The operator is responsible for correct classification of the medical products, defining the reprocessing steps and performing the reprocessing.

9.2 Reprocessing procedures

Perform the reprocessing procedure after each patient treatment and according to the reprocessing procedure:

- Pre-cleaning in accordance with AAMI TIR 30.
- Steam sterilization in accordance with ANSI/AAMI ST81.



Important information!

The reprocessing instructions in accordance with FDA Guidance "Reprocessing Medical Devices in Health Care Settings - Validation Methods and Labeling" have been independently tested by the manufacturer for the preparation of the device and its components for their reuse.

The person conducting the reprocessing is responsible for ensuring that the reprocessing is performed using equipment, materials and personnel that attains the desired results. This requires validation and routine monitoring of the reprocessing process. Any negative consequences resulting from deviation from these instructions by the person conducting the reprocessing are the responsibility of the member of staff performing the reprocessing.

Frequent reprocessing has little effect on the components of the device. The end of the product life cycle is mainly influenced by the amount of wear and tear or damage resulting from its use.

The use of soiled, contaminated and damaged components is at the sole responsibility of the person performing the reprocessing and the operator.

The reprocessing procedure was validated as follows:

- **Pre-cleaning:**
 - Monarch surface disinfection wipes (Air Techniques)
 - Cleaning brush
- **Manual cleaning:**
 - Monarch enzymatic cleaning agent 2.0 % (v/v) (Air Techniques)
- **Automatic cleaning and disinfection** was performed in accordance with EN ISO 15883 with tested efficacy:
 - Washer-disinfector: PG 8535 (Miele, Gütersloh, Germany)
 - Cleaning agent: Neodisher MediClean Forte
 - Programs: *Cleaning without neutralization* and *THERMAL DES*
- **Steam sterilization**
Sterilization type: Dynamic-Air-Removal Steam Sterilization Cycles
 - Pre-vacuum: 3 x
 - Sterilization temperature: at least 270 °F (132 °C)
 - Sterilization time: 2 minutes (half-cycle)
 - Drying time: min. 20 minutes
- **Cleaning brush**
Cleaning brush with nylon bristles, double-sided
 - Number of brush heads: 2
 - Brush material: nylon
 - Brush head length: 1 and 0.4 in
 - Bristle length: 0.2 and 0.4 in
- Example: Interlock cleaning brush, double-sided, green REF 09098

9.3 General information

1. Comply with all national directives, standards and specifications for the cleaning, disinfection and sterilization of medical devices as well as the specific specifications for dental practices and clinics.
2. When selecting the cleaning and disinfectant agents to be used, the information provided (see above) must be followed.
3. Comply with the concentrations, temperatures, residence times and post-rinsing specifications issued by the manufacturer of the cleaning agent and disinfectant.

4. Only use cleaning agents that are non-fixing and aldehyde-free and display material compatibility with the product.
5. Only use disinfectants that are aldehyde-free and display material compatibility with the product.
6. Do not use any rinse aid (danger of toxic residue on the components).
7. Only use freshly-produced solutions.
8. Only use distilled or de-ionized water with a low bacterial count (at least drinking water quality) that is free from facultatively pathogenic microorganisms (e.g. Legionella bacteria).
9. Use clean, dry, oil- and particle-free compressed air.
10. Do not exceed temperatures of 281 °F(138 °C).
11. Subject all devices used (e.g. ultrasonic bath, cleaning and disinfection device (washer-disinfector), sealing device, steam sterilizer) to regular maintenance and inspections.

9.4 Preparation at the operating location



Wear hand protection.



Wear eye protection.



Use a mask.



Wear protective clothing.



WARNING

Risk of infection from contaminated products

Risk of cross contamination

- Reprocess the product correctly and promptly before its first use and after every subsequent use.

1. Protect the unit from contamination when transporting it from the treatment chair to the reprocessing location.
2. Brush off all surfaces below the water surface with a soft hygienic brush until they are clean to the eye.
3. Wipe off all surfaces for at least one minute with a disinfection wipe.

9.5 Clean manually, perform a final rinse, dry

Cleaning agents or combined cleaning and disinfection agents with the following properties must be used for manual cleaning:

- only cleaning and disinfection products approved by Air Techniques
- no aggressive or abrasive cleaning agents

For further information, see "General information".

Cleaning

1. Place the components in a cleaning and disinfection bath (non-fixing/aldehyde-free) making sure that all parts are covered.
2. Note the action times of the cleaning agents and disinfectants.
3. Brush all exterior and interior surfaces with a hygienic brush below the surface of the ready-to-use solution.

Final rinse

After the action time prescribed by the manufacturer has expired:

1. Rinse all components with water for at least 1 minute (temperature < 95 °F (35 °C)).

Drying

1. If necessary, re-dry at a clean location using a hygienic, lint-free cloth.
2. Blow dry the components with compressed air in a clean location.

9.6 Automatic cleaning, intermediate rinsing, disinfection, final rinse, drying

Selection of the washer-disinfector

Automatic cleaning and disinfection requires a washer-disinfector with the following properties and validated processes:

- Meets ANSI/AAMI ST15883-1 with tested efficacy
- Certified program for thermal disinfection (A_0 value ≥ 3000 or at least 5 minutes at 382 °F (194 °C))

Program is suitable for the components and includes sufficient rinsing cycles.

Further information: "9.3 General information".

Selection of the machine cleaning agents and disinfectants

The following properties are required:

- Material compatibility with the product
- Compliance with the washer-disinfector manufacturer's specifications

For further information, see "9.3 General information".

Automatic cleaning and disinfecting



When arranging the parts in the washer-disinfector, make sure there are no areas missed by rinsing.

1. Place components in the baskets for small parts.

9.7 Check for function

1. After the end of the cleaning and disinfection cycle, check the components for any residual soiling and residual moisture. If necessary, repeat the cycle.
2. If necessary, replace any damaged parts.
3. The components should be packaged as soon as possible after drying and checking.

9.8 Steam sterilization

Packing

For packing of the components, only use transparent paper-film sterilization packaging that is approved for use in steam sterilization according to the manufacturer's instructions. This includes:

- Temperature resistance up to 281 °F
- Standards DIN EN ISO 11607-1/2
- The applicable sections of the standard series DIN EN 868

The sterilization packaging must be sufficiently large. Once it is loaded, the sterilization packaging may not be under any strain.

Steam sterilization



WARNING

Health risk due to improper sterilization

If the sterilization is not performed correctly, it may not be effective. The use of insufficiently sterilized instruments can be a health risk to the patient.

- › Only steam sterilization is permissible.
- › Comply with all process parameters.
- › Comply with the manufacturer's instructions regarding the use of the steam sterilizer.
- › Do not use any other procedures.



NOTICE

Damage to equipment due to improper sterilization

Product damage may be caused if the sterilization process is not performed correctly.

- › Comply with the manufacturer's instructions regarding the use of the steam sterilizer.
- › Comply with all process parameters.

Steam sterilizer requirements:

- Complies with EN 13060 or EN 285 and/or ANSI AAMI ST79
- Suitable programs for the products listed (e. g. with hollow bodies: fractionated vacuum procedure including three vacuum steps)
- Sufficient drying of the product
- Validated processes in accordance with ISO 17665 (valid IQ/OQ and product-specific performance appraisal (PQ))

Perform the following steps:

1. Sterilize the parts to be sterilized (at least 20 minutes at 250 °F (121 °C), at least 4 minutes at 270 °F (132 °C) or at least 5 minutes at 274 °F (134 °C)).



Do not exceed a temperature of 281 °F (138 °C) in the process.

Marking

1. Mark the packaged, treated medical device appropriately such as to ensure its safe application.

9.9 Issue clearance for the parts for sterilization

The reprocessing of the medical device ends with the documented clearance for storage and renewed use.

1. Document the release of the medical device after reprocessing.

9.10 Storing parts for sterilization

1. Comply with the stated storage conditions:
 - Store the parts protected against contamination
 - Dust-protected, e.g. in a locked cabinet
 - Protected against moisture
 - Protected against excessive temperature fluctuations
 - Protected against damage

The integrity of the packaging of a sterile medical device be lost as a result of a particular incident and the passage of time.

Potential external contamination of the sterile barrier system should be taken into account in terms of aseptic preparation when establishing the storage conditions.

10 Quality control

The manufacturer recommends carrying out a quality control procedure.

This is divided into acceptance testing and consistency testing.

It is advisable – and in some countries legally required – that the image display system be checked before the acceptance testing of the X-ray device.

During acceptance testing, X-ray images must be displayed and evaluated, which is why optimal prior adjustment and inspection of the monitor is necessary.

The acceptance test is performed by trained personnel at the end of device installation and calibration. The acceptance test ensures that image quality, X-ray dose, and regulatory requirements comply with a defined standard.

During the acceptance test, reference images of the test phantom are created and stored in VistaSoft Inspect.

Consistency tests are performed by the operator. Consistency checking is carried out by taking X-ray exposures of the test phantom using the same dosing parameters as used for the acceptance test (benchmark values).

The requisite tests are determined by local rules and regulations. Carry out testing in accordance with local rules and regulations.

10.1 Applicable standards in Germany

The following standards are primarily applicable with the acceptance test:

- DIN 6868-151 Acceptance testing of dental X-ray equipment according to the X-Ray Ordinance (RöV)
- DIN 6868-157: Acceptance test and consistency check of the image playback system

The following standards are primarily applicable in the consistency check:

- DIN 6868-5: Consistency check according to X-Ray Ordinance (RöV) on dental X-ray equipment
- DIN 6868-157: Acceptance test and consistency check of the image playback system

The following guidelines and ordinances apply as well:

- Radiation Protection Act (Strahlenschutzgesetz, StrlSchG)
- Radiation Protection Ordinance (Strahlenschutzverordnung, StrlSchV)
- Guidelines for Expert Qualifications (Sachverständigen-Richtlinie, SV-RL)
- Quality Assurance Guidelines (Qualitätssicherung-Richtlinie, QS-RL)
- Specialist Knowledge Guidelines (Fachkunde-Richtlinie, FK-RL)

10.2 Applicable standards in other countries

The following standards are primarily applicable with the acceptance test outside of Germany:

- IEC 61223-3-4 (2000-03) Imaging performance of dental X-ray equipment

10.3 Consistency check

Inspection intervals



Authorities in each German federal state can set shorter or longer intervals! The tests have to be recorded and kept available for a period of two years. A chronologically-ordered X-ray control book must be kept and patient-relevant X-ray doses must be recorded.

Consistency testing of the X-ray system (according to DIN 6868-5) is carried out by the operator and must be repeated every 4 weeks (§88 StrlSchV).

Every 5 years, a recurring test has to be carried out by an expert.

We recommend performing the acceptance and consistency tests using VistaSoft Inspect.

VistaSoft Inspect detects which device is being tested and adapts the required test procedure to the device's specifications.

For information on how to perform the checks with VistaSoft Inspect, please refer to the VistaSoft Inspect software assistant.

Panoramic

1. Attach the primary absorber set for Pano/Ceph Cu 1.8 mm to the exit of the X-ray tube.

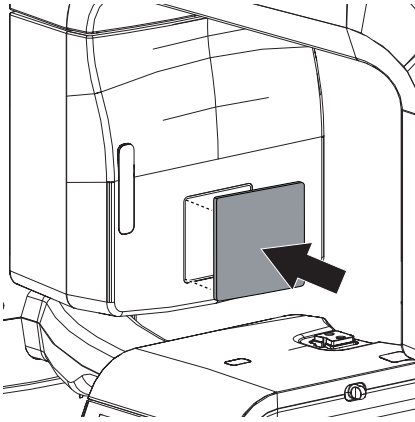

2. Dismantle the Intra/Extra test phantom for Pano and remove the test element.
3. Place the test phantom holder and 6 mm of aluminium between the X-ray tube and the detector.

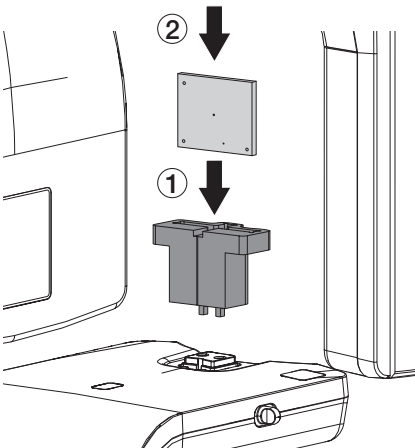

4. Activate the beam localizer for the mid-sagittal section.

5. Check the center alignment.

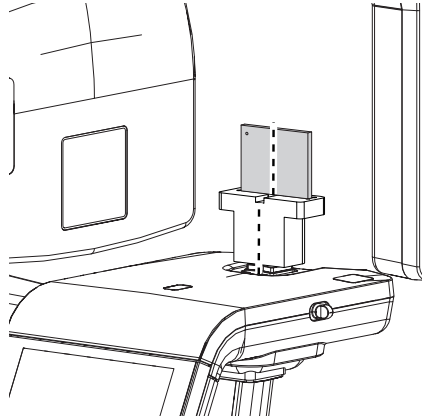

6. Adjust the canine beam localizer.
 - i** The canine beam localizer must run over the notch in the test phantom holder.

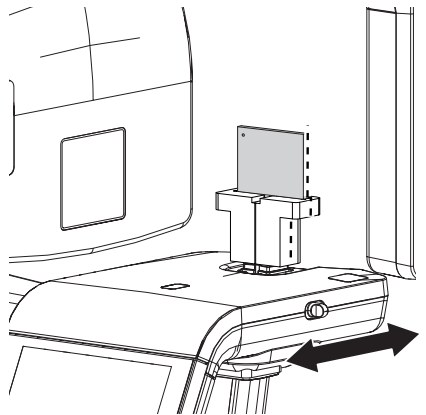

7. Start consistency test.

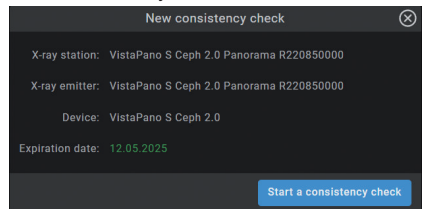

- Reference recording is loaded.



- Click **Start X-ray image acquisition**.
- Compare the generated X-ray image with the reference image.
- Enter all details of the X-ray image.

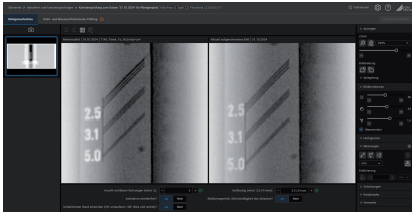

- In the **Visual inspection and test measurement** registration tab, fill out the column **Additional information about the check**.

- Finalize check.**

Cephalometric

- Attach the primary absorber set for Pano/Ceph Cu 0.8 mm to the exit of the X-ray tube.

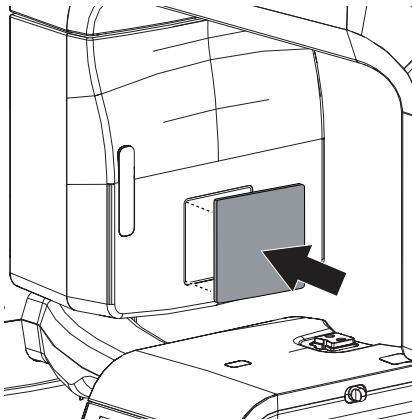

- Remove the pano test phantom and take out the test element.

- Place the test element holder and the test element.

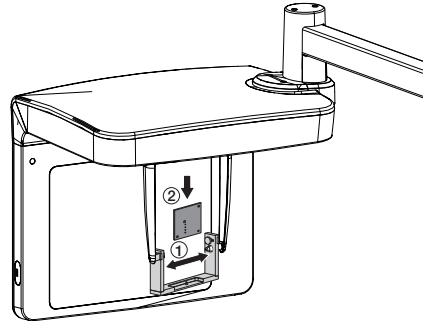

- Start the consistency test.

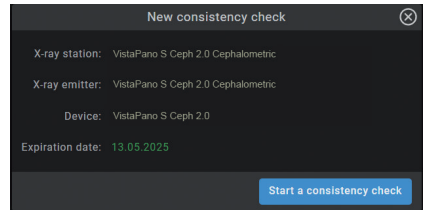

- The reference image will be loaded.

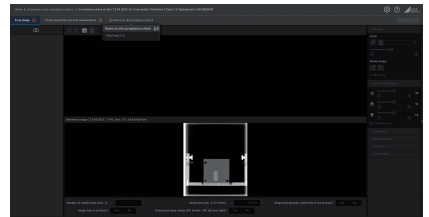

- Click **"Start image acquisition"**.
- Confirm the acquisition on the touch screen of the unit by clicking on **Start**.
- Determine the number of holes and the number of line pairs in the image.



- Enter all values.

10. In the *Visual and Measurement Testing* tab, fill the column titled *Additional information on the test*.
11. *Finalize check*

10.4 Quality control measures



Descriptions and instructions to assist in the repair of parts are provided specifically by Air Techniques approved and authorized service personnel. For technical assistance with quality control procedures, contact your local service representative.

Pano

Test	Frequency	Testing tool	Permissible criteria			
Resolution of line pairs	Every six months	Test phantom/ VistaSoft VistaSoft Inspect	≥3.1 lp/mm			
Low contrast resolution	Every six months	Test phantom/ VistaSoft VistaSoft Inspect	2.0 mm			
Panoramic layer	Every six months	VistaSoft Inspect	Centering: 1382 ± 10 pixels Permissible range between left and right-hand pin: ±10 pixels			
Tube voltage	Annually	Voltmeter	≤ 10% of the specified value			
Limitation and alignment of the X-ray beam (4% slice)	Annually	VistaSoft Inspect	Adult			
			Collimator	Min. pixels	Max. pixels	
			Threshold value 70%	Left	1	8
				Right	5	20
				Top	10	40
				Bottom	10	40
			Child	Collimator	Min. pixels	Max. pixels
			Threshold value 70%	Left	1	8
				Right	350	450
				Top	10	40
Bottom	10	40				

Ceph

Test	Frequency	Testing tool (Phantom/S W)	Permissible criteria
Resolution of line pairs	Every six months	Test phantom / VistaSoft VistaSoft Inspect	≥3.1 lp/mm

Test	Frequency	Testing tool (Phantom/S W)	Permissible criteria			
Low contrast resolution	Every six months	Test phantom / VistaSoft VistaSoft Inspect	2.5 mm			
Tube voltage	Annually	Voltmeter	≤ 10% of the specified value			
Limitation and alignment of the X-ray beam (4% slice)	Annually	VistaSoft Inspect	HD			
			Collimator	Min. pixels	Max. pixels	
			Threshold value 90 %	Left	1	20
				Right		
				Top	40	80
				Bottom		
			SD			
			Collimator	Min. pixels	Max. pixels	
			Threshold value 90 %	Left	1	10
				Right		
Top	20	40				
Bottom						

11 Maintenance

11.1 Recommended maintenance schedule

Please contact the Service department if there are discrepancies in the DAP values.



The following must be noted during maintenance work.

- › The unit and the accessories required for its use must be set up in a dry room only. It must be ensured for the long term that the equipment remains in good condition.
- › The operation of the device can be influenced by factors such as temperature, light, ventilation, dust, salt etc.
- › All of the utensils required to take an X-ray should be carefully positioned to enable an effective work flow.
- › Check that the unit has an earth connection.
- › Do not fix the unit or cables yourself. This could lead to injuries or to damage to the unit.

Regular work to be performed by the user



Prior to working on the unit or in case of danger, disconnect it from the mains power.

Inspection interval	Inspection work
Daily	<ul style="list-style-type: none"> › Before starting up the unit, make sure that the unit and the positioning aids have been cleaned and disinfected, see "8 Cleaning and disinfection". › Is the unit switched off when no more X-ray images are to be taken? › Functional test of the exposure button including status LED.
Weekly	<ul style="list-style-type: none"> › Make sure that there is no damage to the mains cable. › Functional test of the EMERGENCY OFF button. Is the EMERGENCY OFF button easy to operate mechanically, and does it light up when pressed?
Monthly	<ul style="list-style-type: none"> › Make sure that all information signs and the type plates on the unit are undamaged and clearly legible. › Functional test of the speech output.

Regular work to be performed by the service technician



The unit may be serviced only by qualified personnel or personnel trained by the manufacturer.



Prior to working on the unit or in case of danger, disconnect it from the mains power.

Inspection interval	Inspection work
Every 3 years	<ul style="list-style-type: none">› Functional test of the display. Are all symbols displayed?› Functional test of the exposure button.› Do the various status LEDs light up?› Check that the mechanism of the head supports works correctly. Are the head supports easy to detach and put back on?› Functional test of the EMERGENCY OFF button. Is the EMERGENCY OFF button mechanically easy to operate?› Light barrier test for all light barriers installed in the unit.› Visually check the positioning beams. Check the operation of the adjustment lever for the canine positioning beam.› Check the X-ray images for artifacts. If necessary, adjust the collimator and/or calibrate the sensor.› Check the firmware and software versions.› Perform a comparative dose measurement based on the requirements from the acceptance test (Germany, Switzerland and Austria only).› Recurring tests and tests after repair of medical electrical equipment - DIN EN 62353 (VDE 0751-1).

Maintenance interval	Maintenance work
Every 3 years	<ul style="list-style-type: none">› Visually and acoustically check the linear movement on the rotating unit. If necessary, clean the slide rails with alcohol and grease them with Vaseline.› Check the operation of the lift motor. Does the unit lift and lower without any noise? If necessary, clean with alcohol and grease with Vaseline.



The unit may be serviced only by qualified personnel or personnel trained by the manufacturer.



Prior to working on the unit or in case of danger, disconnect it from the mains power.

Inspection interval	Inspection work
Every 3 years	<ul style="list-style-type: none"><li data-bbox="295 169 1049 193">› Functional test of the display. Are all symbols displayed?<li data-bbox="295 201 1049 225">› Do the various status LEDs light up?<li data-bbox="295 233 1049 312">› Check to make sure that the head supports and nose support mechanism works properly. Are the head supports and nose support easy to detach and attach?<li data-bbox="295 320 1049 344">› Light barrier test for all light barriers installed in the unit.<li data-bbox="295 352 1049 400">› Visually check the positioning beams. Check the operation of the adjustment lever for the canine positioning beam.<li data-bbox="295 408 1049 456">› Check the X-ray images for artifacts. If necessary, adjust the collimator and/or calibrate the sensor.<li data-bbox="295 464 1049 488">› Check the firmware and software versions.<li data-bbox="295 496 1049 544">› Perform a comparative dose measurement based on the requirements from the acceptance test (Germany, Switzerland and Austria only).<li data-bbox="295 552 1049 624">› Recurring tests and tests after repair of medical electrical equipment - DIN EN 62353 (VDE 0751-1).
Maintenance interval	Maintenance work
Every 3 years	<ul style="list-style-type: none"><li data-bbox="295 711 1049 759">› Visually and acoustically check the linear movement on the rotating unit. If necessary, clean the slide rails with alcohol and grease them with Vaseline.<li data-bbox="295 767 1049 825">› Check the operation of the lift motor. Does a signal sound when the unit is raised and lowered? If necessary, clean with alcohol and grease with Vaseline.

Installation

12 Establishing the electrical connections

Requirements:

- The connection to the mains supply must be a fixed connection that can only be released using a tool. Plug-in connections (power outlet/plug) are not permissible.
- An all-pole disconnection unit (all-pole switch) is installed in the electrical connection to the mains power supply. This satisfies the creepage distances and air gaps specified in IEC 61058-1 for a mains voltage peak of 4 kV.
- The disconnection unit (switch) is easily and safely accessible.
- Mains fuse (16 A) present in the mains supply (protective circuit breaker characteristic B in accordance with IEC EN60898)
- Internal resistance of the mains supply $< 0.5 \Omega$

12.1 Electrical safety when making connections

1. Make sure that none of the electrical cables leading to the unit are under any mechanical tension.
 2. Before start-up, check the mains voltage against the voltage indicated on the type plate (see also "4.4 Model identification plate").
- Make sure that the electrical connections to the mains power supply are established in accordance with current valid national and local regulations and standards governing the installation of low voltage units in medical facilities.
 - Note the current consumption of the devices that are to be connected.

Troubleshooting

13 Tips for operators and service technicians

 Any repairs above and beyond routine maintenance may only be done by suitably qualified personnel or by one of our service technicians.

Error	Possible cause	Remedy
Unit does not switch on	EMERGENCY STOP SWITCH accidentally activated	› Releasing the EMERGENCY STOP SWITCH.
	No mains voltage	› Check the mains cable and electrical connection; replace if necessary. › Contact technician. › Check the mains fuse in the building.
	On/off switch is defective	› Contact technician.
Unit not responding	The unit has not yet completed the startup procedure	› After switching on, wait until the booting process has finished.
	Unit is blocked by the firewall	› Enable the ports for the unit in the firewall settings. You can find the network connection in the installation manual (document no. A9302).
	The unit has no connection to the computer. The E-Grabber Controller Manager symbol in the task bar is gray  .	› Check the cable connection. › Check network settings. › Inform a service technician.

Appendix

14 Default values

14.1 Pano

Scan and exposure times

Program	Arch	HD		SD	
		Exposure time s	Scan time s	Exposure time s	Scan time s
Standard pan- oramic	Wide	13.5	14.0	7.2	7.5
	Normal	13.5	14.0	7.2	7.5
	Narrow	13.5	14.0	7.2	7.5
	Child	11.5	12.3	6.1	6.4
Right, Left	Wide	6.7	14.0	3.6	7.5
	Normal	6.7	14.0	3.6	7.5
	Narrow	6.7	14.0	3.6	7.5
	Child	5.7	12.3	3.1	6.4
Front	Wide	11.2	14.0	6.0	7.5
	Normal	11.2	14.0	6.0	7.5
	Narrow	11.2	14.0	6.0	7.5
	Child	9.2	12.3	4.9	6.4
Orthogonal	Standard	13.5	13.8	13.5	13.8
Bitewing		9.7	13.8	9.7	13.8
Bitewing Right, Left		4.8	13.8	4.8	13.8
Bitewing Front		2.4	13.8	2.4	13.8
Sinus, lateral	Wide	5.9	6.5	5.9	6.5
	Normal	5.9	6.5	5.9	6.5
	Narrow	5.9	6.5	5.9	6.5
	Child	5.9	6.5	5.9	6.5
Sinus, PA	Wide	10.3	10.9	10.3	10.9
	Normal	10.3	10.9	10.3	10.9
	Narrow	10.3	10.9	10.3	10.9
	Child	10.3	10.9	10.3	10.9
Maxillary joint, lateral	Wide	6.2	14.0	6.2	14.0
	Normal	6.2	14.0	6.2	14.0
	Narrow	6.2	14.0	6.2	14.0
	Child	6.2	14.0	6.2	14.0

Program	Arch	HD		SD	
		Exposure time	Scan time	Exposure time	Scan time
		s	s	s	s
Maxillary joint PA	Wide	5.3	11.6	5.3	11.6
	Normal	5.3	11.6	5.3	11.6
	Narrow	5.3	11.6	5.3	11.6
	Child	5.3	11.6	5.3	11.6

Scan time: The actual time that the equipment shoots the patient except for the initial acceleration and late deceleration stages.

Exposure time: The actual time that the patient is exposed to the X-ray emission.

Tube voltage and current

Mode	Patient	HD		SD	
		Voltage kVp	Current mA	Voltage kVp	Current mA
Standard	Large	74	10.0	74	12.0
	Average	73	10.0	73	12.0
	Small	72	10.0	72	11.0
	Child	67	8.0	67	10.0
Right, Left	Large	74	10.0	74	12.0
	Average	73	10.0	73	12.0
	Small	72	10.0	72	11.0
	Child	67	8.0	67	10.0
Front	Large	74	10.0	74	12.0
	Average	73	10.0	73	12.0
	Small	72	10.0	72	11.0
	Child	67	8.0	67	10.0
Orthogonal	Large	74	10.0	74	10.0
	Average	73	10.0	73	10.0
	Small	72	10.0	72	10.0
	Child	67	8.0	67	8.0
Sinus, lateral	Large	74	10.0	74	10.0
	Average	73	10.0	73	10.0
	Small	72	10.0	72	10.0
	Child	67	8.0	67	8.0
Sinus, PA	Large	74	10.0	74	10.0
	Average	73	10.0	73	10.0
	Small	72	10.0	72	10.0
	Child	67	8.0	67	8.0

Mode	Patient	HD	Current mA	SD	Current mA
		Voltage kVp		Voltage kVp	
Maxillary joint, lateral	Large	74	10.0	74	10.0
	Average	73	10.0	73	10.0
	Small	72	10.0	72	10.0
	Child	67	8.0	67	8.0
Maxillary joint PA	Large	74	10.0	74	10.0
	Average	73	10.0	73	10.0
	Small	72	10.0	72	10.0
	Child	67	8.0	67	8.0

14.2 Ceph

Scan and exposure times

Program	HD	Scan time s	SD	Scan time s
	Exposure time s		Exposure time s	
Head lateral	7.7	8.4	1.9	2.1
Head lateral full format			3.9	4.2
Head PA / Waters View / SMV	7.7	8.3	2.4	2.6
Carpus	7.7	8.3	2.4	2.6

Tube voltage and current

Mode	Patient	HD	Current mA	SD	Current mA
		Voltage kVp		Voltage kVp	
Head lateral	Large	92	15.0	92	16.0
	Average	90	15.0	90	16.0
	Small	88	15.0	88	16.0
	Child	86	15.0	86	16.0
Head lateral full format	Large			92	14.0
	Average			90	14.0
	Small			88	14.0
	Child			86	14.0
Head PA / Waters View / SMV	Large	92	14.0	92	15.0

Mode	Patient	HD	Current	SD	Current
		Voltage kVp	mA	Voltage kVp	mA
	Average	90	14.0	90	15.0
	Small	88	14.0	88	15.0
	Child	86	14.0	86	15.0
Carpus	Large	90	6.0	90	6.0
	Average	88	6.0	88	6.0
	Small	86	6.0	86	6.0
	Child	84	6.0	84	6.0

15 Panoramic program parameters

The digital extraoral dental X-ray system meets the requirements set out in standard IEC 60601-2-63. The dosage information complies with the requirements of the standard and is stated in mGy.

Radiation accuracy: Information about the overall uncertainty of the stated values for air kerma and dose area product shall be noted in the accompanying document and must not exceed 50%.

If the operator changes the parameters “Voltage” and “Current”, the resulting radiation quantity may differ from the stated values.

The X-rays generated by the X-ray focal spot pass through the X-ray beam limiter for each patient position to create an image receiving area.

The dose area product is calculated by a combination of the air kerma measured in the image receiver and the reception area.

Test conditions

Model	VistaPano S
Brand	Xmaru1501CF-Plus
X-ray emitter model	DG-07E22T2
X-ray tube model	D-052SB
DAP measurement	If the mode has been set for each of the modes listed below and the dose meter for DAP measurement has been attached to the side of the X-ray detector, the dose value generated during X-ray exposure can be measured for each mode.

15.1 Large built patient

Image quality	Program	Arch	Voltage	Current	DAP mGy cm^2	Exposure time
			kV	mA		s
SD	Standard panoramic	Wide	74	12	104.1	7.2
		Child	74	12	73.2	6.1
	Right, Left	Wide	74	12	52.1	3.6
		Child	74	12	36.6	3.1
	Front	Wide	74	12	87.4	6.0
		Child	74	12	55.5	4.9

Image quality	Program	Arch	Voltage	Current	DAP mGy cm^2	Exposure time
			kV	mA		s
HD	Standard panoramic	Wide	74	10	160.1	13.5
		Child	74	10	101.9	11.5
	Right, Left	Wide	74	10	80.0	6.7
		Child	74	10	50.9	5.7
	Front	Wide	74	10	126.0	11.2
		Child	74	10	79.6	9.2

Image quality	Program	Arch	Voltage	Current	DAP	Exposure time
			kV	mA	mGycm ²	s
SD/HD	Bitewing	Wide	74	10	87.4	9.7
		Child	74	10	87.4	9.7
	Bitewing Right, Left	Wide	74	10	43.8	4.8
		Child	74	10	43.8	4.8
	Bitewing Front	Wide	74	10	22.2	2.4
		Child	74	10	22.2	2.4
	Orthogonal	Wide	74	10	160.1	13.5
		Child	74	10	123.4	13.5
	Sinus Lat	Wide	74	10	70.3	5.9
		Child	74	10	54.1	5.9
	Sinus PA	Wide	74	10	120.9	10.3
		Child	74	10	93.0	10.3
	Maxillary joint Lat	Wide	74	10	73.7	6.2
		Child	74	10	56.8	6.2
	Maxillary joint PA	Wide	74	10	64.0	5.3
		Child	74	10	49.1	5.3

15.2 Average built patient

Image quality	Program	Arch	Voltage	Current	DAP	Exposure time
			kV	mA	mGycm ²	s
SD	Standard panoramic	Wide	73	12	101.6	7.2
		Child	73	12	71.5	6.1
	Right, Left	Wide	73	12	50.8	3.6
		Child	73	12	35.8	3.1
	Front	Wide	73	12	85.3	6.0
		Child	73	12	54.2	4.9

Image quality	Program	Arch	Voltage	Current	DAP	Exposure time
			kV	mA	mGycm ²	s
HD	Standard panoramic	Wide	73	10	157.0	13.5
		Child	73	10	100.0	11.5
	Right, Left	Wide	73	10	78.4	6.7
		Child	73	10	49.9	5.7
	Front	Wide	73	10	123.6	11.2
		Child	73	10	78.1	9.2

Image quality	Program	Arch	Voltage kV	Current mA	DAP mGycm ²	Exposure time s
SD/HD	Bitewing	Wide	73	10	85.2	9.7
		Child	73	10	85.2	9.7
	Bitewing Right, Left	Wide	73	10	42.7	4.8
		Child	73	10	42.7	4.8
	Bitewing Front	Wide	73	10	21.4	2.4
		Child	73	10	21.4	2.4
	Orthogonal	Wide	73	10	157.0	13.5
		Child	73	10	121.0	13.5
	Sinus Lat	Wide	73	10	68.6	5.9
		Child	73	10	52.8	5.9
	Sinus PA	Wide	73	10	117.7	10.3
		Child	73	10	90.6	10.3
	Maxillary joint Lat	Wide	73	10	71.8	6.2
		Child	73	10	55.3	6.2
	Maxillary joint PA	Wide	73	10	62.3	5.3
		Child	73	10	47.8	5.3

15.3 Small patient

Image quality	Program	Arch	Voltage kV	Current mA	DAP mGycm ²	Exposure time s
SD	Standard panoramic	Wide	72	11	90.8	7.2
		Child	72	11	63.9	6.1
	Right, Left	Wide	72	11	45.4	3.6
		Child	72	11	32.0	3.1
	Front	Wide	72	11	76.2	6.0
		Child	72	11	48.5	4.9

Image quality	Program	Arch	Voltage kV	Current mA	DAP mGycm ²	Exposure time s
HD	Standard panoramic	Wide	72	10	153.9	13.5
		Child	72	10	98.0	11.5
	Right, Left	Wide	72	10	76.9	6.7
		Child	72	10	48.9	5.7
	Front	Wide	72	10	121.2	11.2
		Child	72	10	76.5	9.2

Image quality	Program	Arch	Voltage	Current	DAP	Exposure time
			kV	mA	mGycm ²	s
SD/HD	Bitewing	Wide	72	10	83.1	9.7
		Child	72	10	83.1	9.7
	Bitewing Right, Left	Wide	72	10	41.6	4.8
		Child	72	10	41.6	4.8
	Bitewing Front	Wide	72	10	20.8	2.4
		Child	72	10	20.8	2.4
	Orthogonal	Wide	72	10	153.9	13.5
		Child	72	10	118.6	13.5
	Sinus Lat	Wide	72	10	66.9	5.9
		Child	72	10	51.5	5.9
	Sinus PA	Wide	72	10	114.6	10.3
		Child	72	10	88.2	10.3
	Maxillary joint Lat	Wide	72	10	70.0	6.2
		Child	72	10	53.9	6.2
	Maxillary joint PA	Wide	72	10	60.7	5.3
		Child	72	10	46.6	5.3

15.4 Child (<12 years)

Image quality	Program	Arch	Voltage	Current	DAP	Exposure time
			kV	mA	mGycm ²	s
SD	Standard panoramic	Wide	67	10	72.6	7.2
		Child	67	10	51.1	6.1
	Right, Left	Wide	67	10	36.2	3.6
		Child	67	10	25.5	3.1
	Front	Wide	67	10	61.1	6.0
		Child	67	10	38.8	4.9

Image quality	Program	Arch	Voltage	Current	DAP	Exposure time
			kV	mA	mGycm ²	s
HD	Standard panoramic	Wide	67	8	109.4	13.5
		Child	67	8	69.6	11.5
	Right, Left	Wide	67	8	54.7	6.7
		Child	67	8	34.8	5.7
	Front	Wide	67	8	86.2	11.2
		Child	67	8	54.4	9.2

Image quality	Program	Arch	Voltage kV	Current mA	DAP mGycm ²	Exposure time s
SD/HD	Bitewing	Wide	67	8	58.4	9.7
		Child	67	8	58.4	9.7
	Bitewing Right, Left	Wide	67	8	29.2	4.8
		Child	67	8	29.2	4.8
	Bitewing Front	Wide	67	8	14.6	2.4
		Child	67	8	14.6	2.4
	Orthogonal	Wide	67	8	109.4	13.5
		Child	67	8	84.3	13.5
	Sinus Lat	Wide	67	8	47.0	5.9
		Child	67	8	36.2	5.9
	Sinus PA	Wide	67	8	80.5	10.3
		Child	67	8	61.9	10.3
	Maxillary joint Lat	Wide	67	8	49.1	6.2
		Child	67	8	37.8	6.2
	Maxillary joint PA	Wide	67	8	42.6	5.3
		Child	67	8	32.7	5.3

16 Ceph program parameters

The extraoral dental X-ray system meets the requirements set out in standard IEC 60601-2-63. The dosage information complies with the requirements of the standard and is stated in mGy.

Radiation accuracy: Information about the overall uncertainty of the stated values for air kerma and dose area product shall be noted in the accompanying document and must not exceed 50%.

If the operator changes the parameters “Voltage” and “Current”, the resulting radiation quantity may differ from the stated values.

The X-rays generated by the X-ray focal spot pass through the X-ray beam limiter for each patient position to create an image receiving area.

The dose area product is calculated by a combination of the air kerma measured in the image receiver and the reception area.

16.1 Large built patient

Image quality	Program	Voltage	Current	DAP	Exposure time
		kV	mA	mGycm ²	s
SD	Head, lateral	92	16	17.7	1.9
	Head lateral full format	92	14	30.5	3.9
	Head PA	92	15	20.5	2.4
	SMV	92	15	20.5	2.4
	Waters View	92	15	20.5	2.4
	Carpus	90	6	7.8	2.4

Image quality	Program	Voltage	Current	DAP	Exposure time
		kV	mA	mGycm ²	s
HD	Head, lateral	92	15	72.4	7.7
	Head PA	92	14	66.0	7.7
	SMV	92	14	66.0	7.7
	Waters View	92	14	66.0	7.7
	Carpus	90	6	27.3	7.7

16.2 Average built patient

Image quality	Program	Voltage	Current	DAP	Exposure time
		kV	mA	mGycm ²	s
SD	Head, lateral	90	16	23.5	1.9
	Head lateral full format	90	14	39.5	3.9
	Head PA	90	15	27.2	2.4
	SMV	90	15	27.2	2.4
	Waters View	90	15	27.2	2.4
	Carpus	88	6	11.3	2.4

Image quality	Program	Voltage	Current	DAP	Exposure time
		kV	mA	mGycm ²	s
HD	Head, lateral	90	15	90.9	7.7
	Head PA	90	14	87.4	7.7
	SMV	90	14	87.4	7.7
	Waters View	90	14	87.4	7.7
	Carpus	88	6	38.2	7.7

16.3 Small patient

Image quality	Program	Voltage	Current	DAP	Exposure time
		kV	mA	mGycm ²	s
SD	Head, lateral	88	16	22.5	1.9
	Head lateral full format	88	14	37.9	3.9
	Head PA	88	15	26.2	2.4
	SMV	88	15	26.2	2.4
	Waters View	88	15	26.2	2.4
	Carpus	86	6	10.9	2.4

Image quality	Program	Voltage	Current	DAP	Exposure time
		kV	mA	mGycm ²	s
HD	Head, lateral	88	15	87.4	7.7
	Head PA	88	14	84.4	7.7
	SMV	88	14	84.4	7.7
	Waters View	88	14	84.4	7.7
	Carpus	86	6	36.9	7.7

16.4 Child (<12 years)

Image quality	Program	Voltage	Current	DAP	Exposure time
		kV	mA	mGycm ²	s
SD	Head, lateral	86	16	21.5	1.9
	Head lateral full format	86	14	36.3	3.9
	Head PA	86	15	25.1	2.4
	SMV	86	15	25.1	2.4
	Waters View	86	15	25.1	2.4
	Carpus	84	6	10.4	2.4

Image quality	Program	Voltage kV	Current mA	DAP mGycm²	Exposure time s
HD	Head, lateral	86	15	84.0	7.7
	Head PA	86	14	81.5	7.7
	SMV	86	14	81.5	7.7
	Waters View	86	14	81.5	7.7
	Carpus	84	6	35.6	7.7

17 Information on scattered radiation

17.1 Measuring conditions

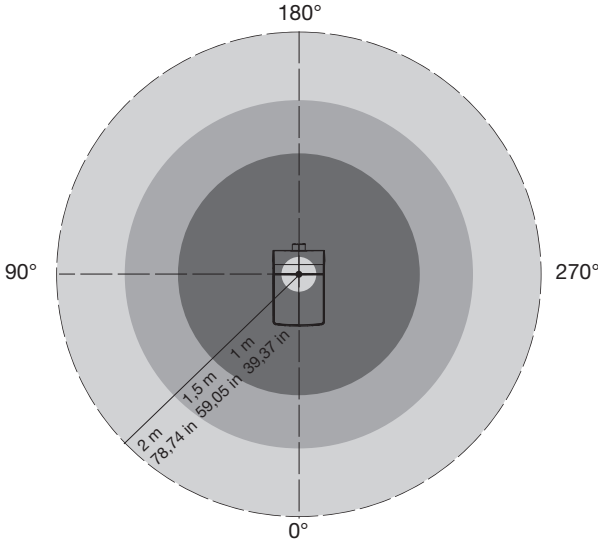

17.2 Pano, adult

Test conditions standard Pano, adult

Distance from focal point	1 m, 1.5 m, 2 m 39.37 in, 59.05 in, 78.74 in
Generator voltage	90 kVp
Current	14 mA
Exposure time	13.5 s

R	°	HD, 13.5 s		
		1 m 39.37 in	1.5 m 59.05 in	2 m 78.74 in
0	Nose	0,84 µGy	0,425 µGy	0,242 µGy
45		0,764 µGy	0,47 µGy	0,268 µGy
90	Right ear	0,11 µGy	0,067 µGy	0,048 µGy
135		0,507 µGy	0,276 µGy	0,137 µGy
180	Back of the head	0,541 µGy	0,233 µGy	0,13 µGy
225		0,772 µGy	0,354 µGy	0,183 µGy
270	Left ear	0,869 µGy	0,368 µGy	0,202 µGy
315		1,041 µGy	0,482 µGy	0,252 µGy

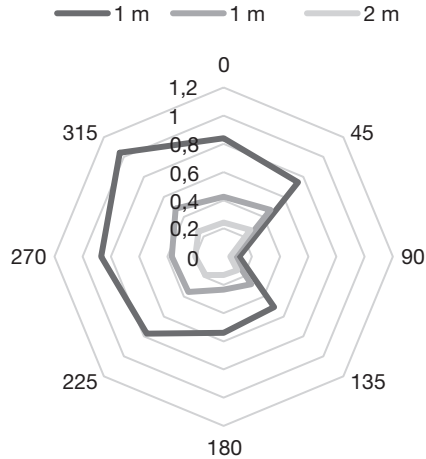

17.3 Pano, pediatric

Test conditions standard Pano, child

Distance from focal point 1 m, 1.5 m, 2 m
39.37 in, 59.05 in, 78.74 in

Generator voltage 90 kVp

Current 14 mA

Exposure time 11.5 s

R	°	HD, 11.5 s		
		1 m 39.37 in	1.5 m 59.05 in	2 m 78.74 in
0	Nose	0.601 μGy	0.299 μGy	0.168 μGy
45		0.648 μGy	0.333 μGy	0.199 μGy
90	Right ear	0.123 μGy	0.059 μGy	0.04 μGy
135		0.559 μGy	0.248 μGy	0.133 μGy
180	Back of the head	0.496 μGy	0.197 μGy	0.106 μGy
225		0.628 μGy	0.246 μGy	0.13 μGy
270	Left ear	0.618 μGy	0.272 μGy	0.137 μGy
315		0.784 μGy	0.347 μGy	0.191 μGy

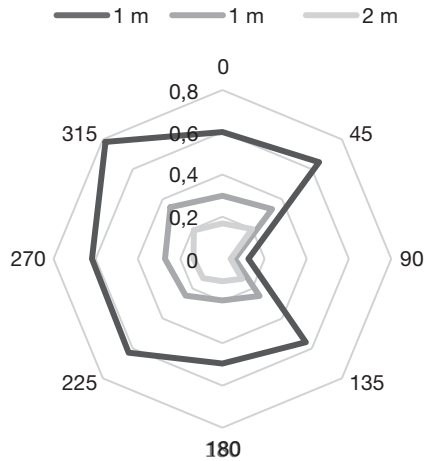

17.4 Ceph, lat

Test conditions Ceph, lat

Distance from focal point	1 m, 1.5 m, 2 m 39.37 in, 59.05 in, 78.74 in
Generator voltage	99 kVp
Current	16 mA
Exposure time	7.7 s

R		1 m 39.37 in	1.5 m 59.05 in	2 m 78.74 in
0	Nose	0.342 µGy	0.229 µGy	0.148 µGy
45		0.472 µGy	0.144 µGy	0.08 µGy
90	Right ear	0.159 µGy	0.094 µGy	0.078 µGy
135		0.326 µGy	0.127 µGy	0.076 µGy
180	Back of the head	0.212 µGy	0.086 µGy	0.068 µGy
225		0.377 µGy	0.362 µGy	0.132 µGy
270	Left ear	-	-	0.229 µGy
315		0.67 µGy	0.818 µGy	0.521 µGy

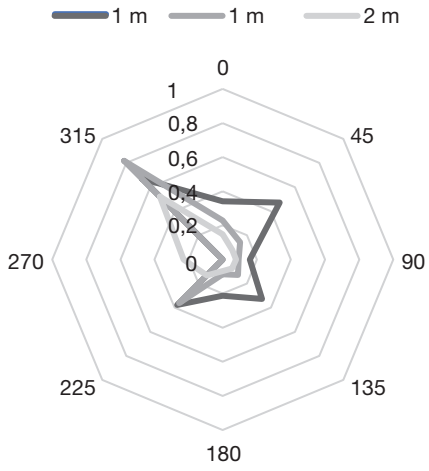

18 Information on the leakage rate

18.1 Measuring conditions

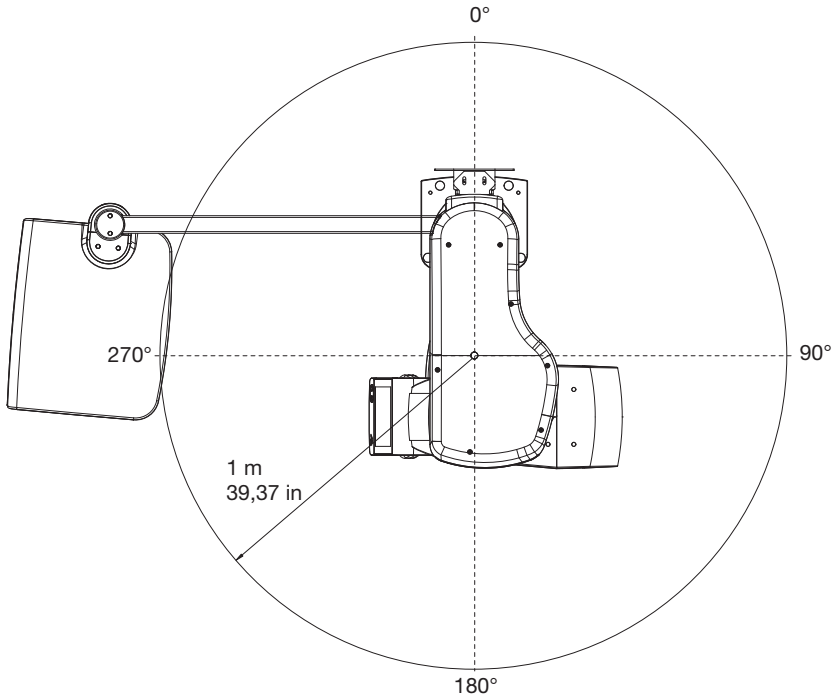

18.2 Standard Pano

Test conditions standard Pano, HD	Adult	Child
Distance from focal point	1 m 39.37 in	
Generator voltage	90 kVp	
Current	14 mA	
Exposure time	13.4 s	11.4 s

Direction °	Adult, dose mGy/h	Child, dose mGy/h
0	0.192	0.177
10	0.107	0.115
20	0.174	0.173
30	0.09	0.089
40	0.069	0.068
50	0.065	0.06

Direction °	Adult, dose mGy/h	Child, dose mGy/h
60	0.068	0.064
70	0.227	0.106
80	0.214	0.11
90	0.019	0.018
100	0.041	0.048
110	0.053	0.068
120	0.051	0.066
130	0.044	0.056
140	0.059	0.161
150	0.052	0.139
160	0.029	0.031
170	0.016	0.018
180	0.011	0.013
190	0.012	0.013
200	0.072	0.071
210	0.021	0.024
220	0.012	0.012
230	0.009	0.01
240	0.008	0.009
250	0.007	0.008
260	0.008	0.008
270	0.01	0.009
280	0.015	0.014
290	0.013	0.013
300	0.011	0.036
310	0.012	0.032
320	0.035	0.032
330	0.032	0.037
340	0.113	0.111
350	0.084	0.08

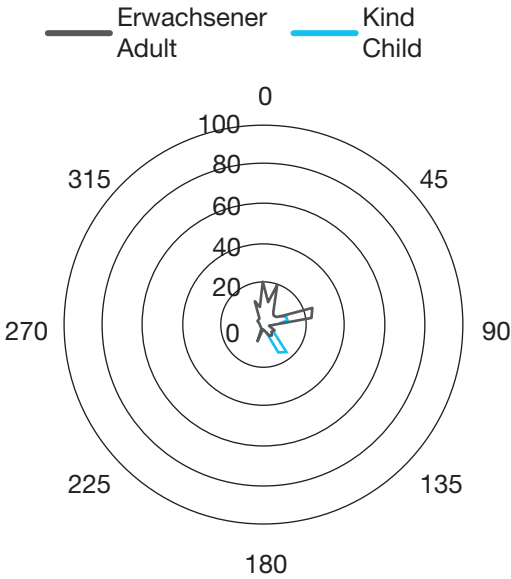

18.3 Ceph

Test conditions Ceph

Distance from focal point	1 m 39.37 in
Generator voltage	99 kVp
Current	16 mA
Exposure time	7.7 s

Direction °	Adult, dose mGy/h
0	0.434
10	0.289
20	0.267
30	0.238
40	0.18
50	0.144
60	0.069
70	0.148
80	0.131
90	0.241
100	0.134
110	0.151
120	0.179

Direction °	Adult, dose mGy/h
130	0.092
140	0.086
150	0.096
160	0.075
170	0.051
180	0.031
190	0.035
200	0.184
210	0.047
220	0.027
230	0.021
240	0.018
250	0.019
260	0.021
270	0.025
280	0.039
290	0.038
300	0.029
310	0.03
320	0.069
330	0.069
340	0.34
350	0.272

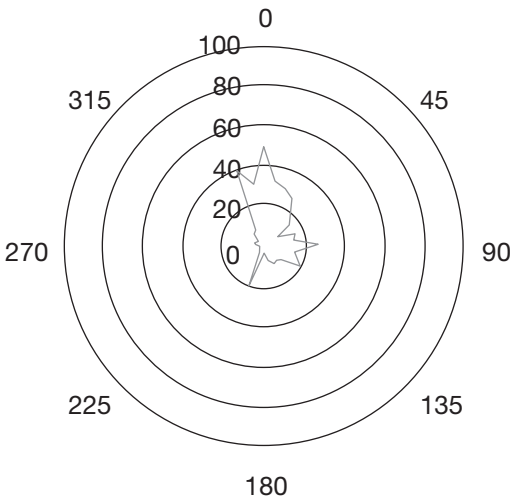

19 Warranty

Air Techniques' Digital Products are warranted to be free from defects in material and workmanship from the date of installation for a limited period. Please visit the Air Techniques website for the most current Warranty Policies and Standard Terms and Conditions.

www.airtechniques.com/warranty



Online Warranty Registration

Quickly and easily register the new Air Techniques product online. Please have the part number and serial number available when logging into the Air Techniques online portal account at

www.airtechniques.com/portal.





Distributed by:

Air Techniques, Inc.
1295 Walt Whitman Road
Melville, New York 11747-3062, USA
Phone: +1 800-247-8324
Fax: +1 888-247-8481
www.airtechniques.com



Hersteller/Manufacturer:

VATECH Co. Ltd.
13, Samsung 1-ro 2-gil
Hwaseong-si, Gyeonggi-do, 18449
Korea
Fon: +82 1588-9510
www.vatech.com

Australian Sponsor:

Emergo Australia | Level 20 Tower II |
Darling Park | 201 Sussex Street
Sydney, NSW 2000 | Australia

